

Hot & Cold Therapy

- 306 - 307 Biofreeze
- 308 Deep Heat/Deep Freeze
- 309 Vulkan
- 310 Donjoy Cold Compression
- 311 Aircast Cryo - Cuff
- 312 - 313 Cold Wraps
- 314 Ice Flakers & Cubers
- 315 Re-usable Hot/Cold Packs
- 316 Cherry Stone Packs/Lavatherm
- 317 Wheat Packs/Thermacare
- 318 Moist Heat Packs
- 319 - 320 Wax Baths & Wax Refills





Freeze your pain with Biofreeze

Biofreeze is the Number 1 recommended topical pain reliever by hands-on healthcare professionals. Biofreeze products help manage discomfort by offering a variety of benefits that assist in therapy, pain relief, exercise, training and overall comfort.

Biofreeze cool soothing relief

Using isopropyl alcohol as the active ingredient, Biofreeze products penetrate quickly, preventing or relieving pain through cryotherapy. The application of cold to decrease inflammation and relieve pain.

The most common form of cryotherapy is ice. Biofreeze produces the same sensation of cold that accompanies icing, but, unlike ice, Biofreeze allows you to remain active during treatment.

Biofreeze is perfect for clinic and home use. Apply generously before and after treatment to further enhance therapies. Biofreeze helps manage pain, improve strength, and restore function to re-establish a normal lifestyle.

Who does Biofreeze help?

Biofreeze can help facilitate pain-free movement, for anyone from athletes to those who simply have demanding occupations. Biofreeze also provides effective relief for people troubled by sore muscles and muscle sprains; back, shoulder and neck pain; arthritis; painful ankle, knee, hip and elbow joints, and muscular strains.

In addition, Biofreeze helps to treat the pain associated with conditions such as diabetic neuropathy, tendonitis, bursitis and plantar fasciitis.

Roll-On

Biofreeze Roll-On allows effective delivery of Biofreeze Gel to smaller muscles and joints throughout the body. The massaging action of the roller ball can be used to stimulate trigger points in the affected area.

Gel

Biofreeze Gel is well suited for hands-on massage applications, particularly larger muscles and joints such as the calves, thighs, shoulders or elbows.

Spray

Biofreeze Cryospray® permits easy, effective application without direct body contact, helping patients at home gain access to hard-to-reach body areas such as the back.

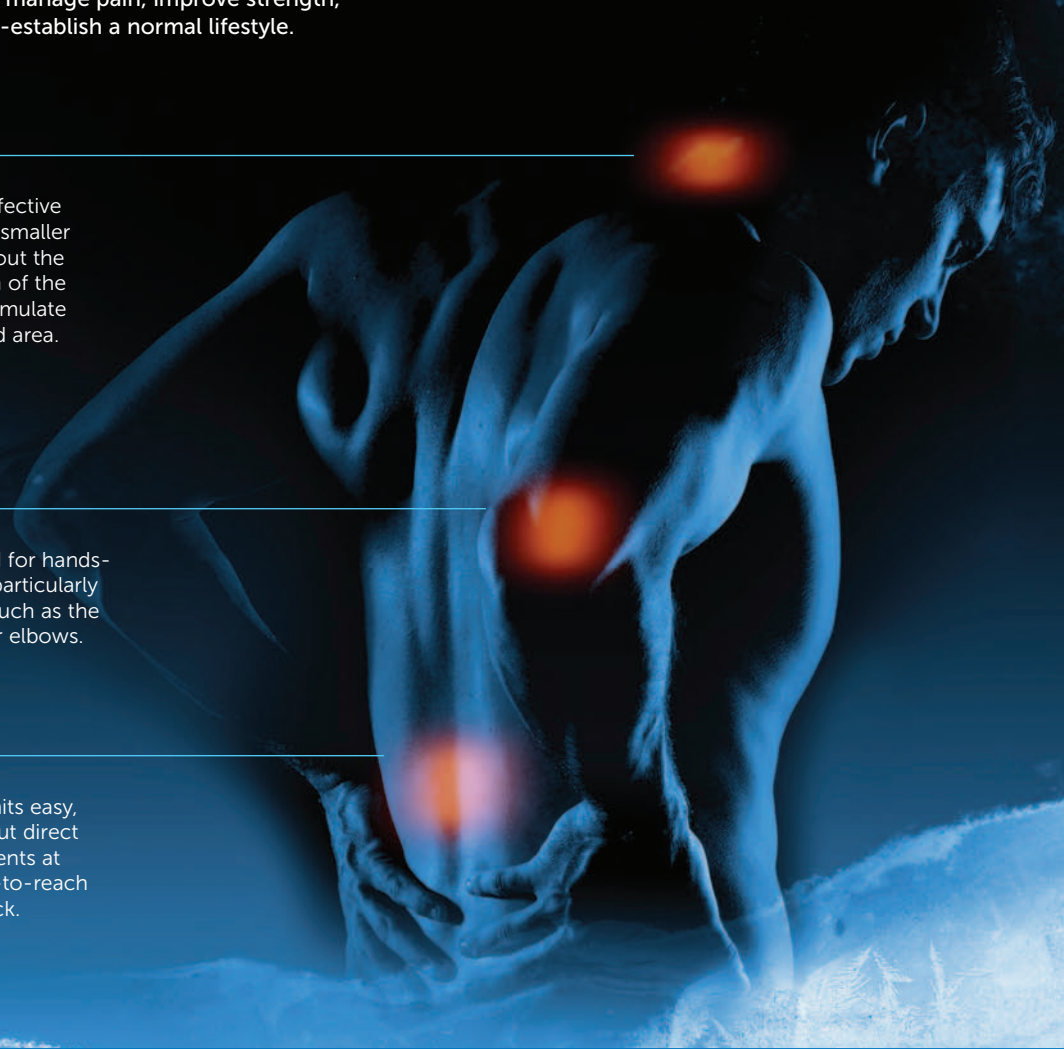



1 BIOFREEZE Gel

COL625	60ml (2oz)
COL630	118ml (4oz)
COL635	473ml (16oz)
COL634	946ml (32oz)

2 BIOFREEZE Spray

09 142 3615	60ml (2oz)
COL694	118ml (4oz)
COL695	473ml (16oz)

3 BIOFREEZE Roll-On

COL636	89ml (4oz)
--------	------------

4 BIOFREEZE Gel Sachets

Not Illustrated

COL637	100 x 5ml
--------	-----------

5 BIOFREEZE Point Of Sale Display

COL641	
--------	--

1



2



3



1 Deep Heat

Deep Heat generates penetrating warmth in tired, injured or sore muscles. The rub and the spray can be used before and after exercise.

- Relieves everyday aches and pains such as tired, sore or overstretched muscles.
- Increases blood supply to relax your muscles and reduce stiffness.
- Also suitable for conditions such as rheumatic pain, sciatica, fibrosis and lumbago.

- 000410** Deep Heat Spray 150ml
- 09 132 0035** Deep Heat Rub 35g
- 09 132 0043** Deep Heat Rub 67g
- 000411** Deep Heat Rub 100g
- 09 132 0050** Deep Heat Max Strength
- 09 132 0076** Deep Heat Patch – Pack of 4
- 09 132 0084** Deep Heat Patch for Back Pain – Pack of 2

2 Deep Freeze

Sporting injuries often involve a blow or overstretched muscles, tendons or joints. Cooling therapy helps to rapidly cool the injured area, by numbing the nerve endings and producing an anaesthetic effect. Deep Freeze Cold Gel is effective for up to 60 minutes.

- Applies cooling therapy to minor injuries.
- Relieves pain in muscles, tendons and joints.

- 09 132 0092** Deep Freeze Gel 35g
- 001200** Deep Freeze Gel 100g
- 09 132 0100** Deep Freeze Patch
- 09 132 0118** Deep Freeze Spray 150ml

3 Prossage™

The intent of Prossage™ Heat, through hands on therapy, is to help restore pain free movement and structural balance throughout the body with minimal effort.

For best results, apply a moderate amount of Prossage™ Heat to the soft tissues leading to a painful area such as the muscle bell leading to the painful tendons of the elbow. Brief circular, cross fibre of palmer friction will enhance the warming effects. Work the tissues from superficial to deep to increase blood flow to the area. The result will help melt the connective tissue adhesions, and reduce ischemia to more effectively reduce chronic pain.

- MAS30** Prossage 3oz Bottle
- MAS35** Prossage 8oz Bottle
- MAS40** Prossage 32oz Bottle



1 Vulkan® Sports Balm

More economical than traditional heat rubs, this pre-sport heat rub comes in a handy size for kit bags and a larger size for the treatment room.

002930 560ml

2 Vulkan® Cooling Spray

Instant cooling effect once sprayed on the skin. Only to be used on minor knocks.

014438 150ml

3 Vulkan® Instant Ice Pack

Ideal for any emergency, these packs are activated by simply squeezing them. They instantly turn ice cold and remain cold for approx 15 minutes.

002408

4 Vulkan® Re-usable Cold/Hot Pack

From the fridge to the microwave, this versatile pack with extra protective sleeve stays flexible whatever the temperature. Conforms well to body contours.

002932

5 Inflatable Ice Bath

Designed for sports teams and clubs to aid recovery after moderate to intense training and competition. Easy to inflate, deflate and transport. Ideal for away games. Includes pump.

017638



6 Medco Instant Heat Pack

Ideal for any emergency, these packs are activated by simply squeezing them. They instantly turn hot and remain hot for approximately 15 minutes.

09 142 2922



1



2



3



4



6



5

1 wk DELIVERY
Delivery is approximately 1 to 2 weeks.
Please contact Customer Services for more information.

ENDORSED BY SALE SHARKS



1



1 ArcticFlow™ Cold Therapy

The ArcticFlow™ cold therapy system is a gravity fed icing device, which operates without the need for a motorised pump and therefore does not require electricity. The 3.5 litre cooler provides up to 3 hours of continuous cold treatment, is lightweight and simple to disconnect from the applied pads. It is easy for the patient to carry around and allows mobility during treatment.

Features and Benefits

- Up to 3 hours continuous cold treatment
- Lightweight 3.5 litre cooler
- Gravity driven, no electricity required
- Easy disconnection allows mobility during treatment

11-1314 ArcticFlow™ Cooler

2 ArcticFlow™ Wraps

In addition to providing the combination of ice and compression, ArcticFlow™ Wraps will dramatically reduce pain and swelling helping facilitate rehabilitation. Once the wrap is filled the patient can disconnect from the unit and will be free to move about. The wrap will stay cold up to 30 minutes, then the patient just re-connects filtering cold water back into the wrap for 3 hours of continuous treatment.

Features and Benefits

- Form filling elastic wraps provide cold and compression to help facilitate the recovery process
- Latex free material
- Welded edges provide superior strength and durability
- Hook and loop strapping is easy to apply and fits most patients

Optional Extras

- 11-1315 Shoulder wrap
- 11-1316 Knee wrap
- 11-1317 Elbow wrap
- 11-1318 Foot/Ankle wrap

2

SHOULDER WRAP



2

KNEE WRAP



2

ELBOW WRAP



2

ANKLE WRAP



AIRCAST®

Aircast Cyro/ Cuff Compression Dressing System

The Aircast system applies simultaneous cold and compression to relieve pain and accelerate rehabilitation. The system is portable and easy to use. It comprises of three component parts.

1. A cuff that covers the specific body part with pressurised ice water.
2. A cooler that holds enough water and ice for 6 to 8 hours of cryotherapy.
3. A tube that exchanges the water between the cooler and the cuff.

1 Aircast Cuff Accessories

- | | | |
|-------------|----------|--------------------------|
| 09 131 9789 | A | Thigh Cuff |
| 09 100 5842 | B | Ankle Cuff |
| 09 100 5917 | C | Small Knee Cuff |
| 09 100 5891 | | Medium Knee Cuff |
| 09 100 5883 | | Large Knee Cuff |
| 09 131 9797 | D | Foot Cuff |
| 09 131 9805 | E | Calf Cuff |
| 09 100 5867 | F | Elbow Cuff |
| 09 100 5909 | G | Shoulder Cuff |
| 09 131 9813 | H | Back, Hips and Ribs Cuff |
| 09 100 5875 | I | Hand and Wrist |

2 Aircast Cryo IC

The Cryo/Cuff IC combines focused compression with cold therapy to provide optimal control of swelling to minimise hemarthrosis, oedema and pain. Simplicity of design and ease of operation makes it ideal for post-operative recovery, trauma, athletic training and home use.

- Focused compression – The Aircast Cryo/Cuffs are anatomically designed to provide specific compression to prevent swelling and reduce pain
- Clinical Studies – Proves that cold and compression is effective in reducing post-operative swelling and regaining ROM
- 30 second on/off cycle – Provides automatic intermittent compression in addition to cold therapy
- Easy to use – Plug it in to start the treatment
- The Cryo/Cuff IC Cold Therapy System provides intermittent compression to minimise hemarthrosis, swelling, and pain.

- 09 131 9821 Cooler & Tube Assembly

3 Aircast Cryo Cooler

Universal to all Cryo/Cuff models, the Cryo/Cuff Cooler holds water and ice needed for six to eight hours of cryotherapy. The durable cooler comes with a tube assembly and insulation disk and is labelled with simple-to-follow directions for use.

- 09 100 5859 Cooler & Tube Assembly



Hot & Cold Therapy

1
LATEX FREE





1 Ice Up™ Portable Ice Massager

The Ice-Up™ Portable Massager provides you with a direct, active ice massage in an easily portable design. It gives you quick, deep tissue penetration focused on target areas. The ergonomic comfort grip barrel offers a controlled ice massage while the patented Ice Grippers allow for a full range of controlled massage pressure.

017827

2 Physicool Bandages

Physicool works by drawing heat out through rapid evaporation, as opposed to most other products that work by driving cold in. Physicool requires no refrigeration, is not messy, needs no mixing and has no unpleasant smells. Physicool is made from a special cotton bandage which has its own natural elasticity to provide good support. The bandage is impregnated with a special cooling fluid which cools by rapid evaporation once applied. The treated area will drop by 10-15°C and stay that way for up to 2-3hrs. Available in two bandage sizes, the smallest being suitable for wrists, knees and ankles and the larger size being suitable for elbows, thighs and shoulders. Spray coolant is also available for replenishing the bandages' cooling properties.

- 09 131 9912 10 x 2cm
- 09 131 9920 12 x 3cm
- 09 131 9938 Coolant Spray



3 Ice Bag

Heavy duty ice bag to reduce swelling and relieve pain, simply fill with ice and apply to desired area. Made from rubber on the inside and cloth on the outside. Has a leak proof cap and washer. A flexible design to fit any part of the body. Colours may vary. To clean, rinse with warm water and let dry. Length 23cm.

AA9740

4 Mueller Heavy Duty Ice Bags

These clear, polyethylene bags are rugged enough to handle even the sharpest ice.

012493 25.4 x 45.7cm



5 Extended Cold Therapy Dorsal Knee Wrap

Rolyan

Kit includes four FIRST+ICE packs and one wrap. Dorsal foam kit and wrap include removable soft foam patella compression piece to support post-arthroscopic dressings (not included with the neoprene kit and wrap). Post-arthroscopic dressing pad included with the dorsal foam kit and wrap only.

- 559400 Dorsal Neoprene Kit
- 559401 Dorsal Neoprene Wrap - Only



6 Readywrap Stretch Tape and Dispensers

Readywrap is the industry standard for holding an ice bag to an injury. Plastic film clings to itself with no sticky residue. It holds the bag firmly in place and at the same time provides compression to the injured area. Stretch film is more economical than tape or ace bandages. One inch cardboard handle fits easily in the hand and is completely disposable. Try the new Readywrap II dispenser with a foam grip handle and effortless roll changes.

- RW1 Readywrap II 4"
 - RW2 Readywrap II 6"
- (pack of 6 rolls & handy roller)

1 Torex Radial Cryo Sleeves

Patented, limb encompassing, radial design surrounds the treatment area. This form delivers maximum cryotherapy, which rapidly lowers the temperature of tissues. Proprietary phase change ice gel turns into a thick long lasting frozen paste. This allows for extended, consistent and uniform delivery of cryotherapy. Gel vessel is made from ultra-comfortable polyurethane elastomer film. Reusable, latex free, non-toxic and effective.

- 09 131 9839 Finger Sleeve 3-10cm
- 09 131 9847 Hand/Wrist/Foot Sleeve 10-25cm
- 09 131 9854 Elbow/Foot/Ankle 25-38cm
- 09 131 9862 Leg/Knee 38-53cm



2 Pro-Tec Cold/Hot Therapy Wraps

Provides penetrating cold and/or heat for therapeutic relief. Form fitting - remains flexible during application. 3" wide dual strapping system effectively compresses entire target area evenly. Advanced gel technology retains cold or heat longer.

- 09 131 9896 Foot/ Ankle/Leg/Knee/Elbow/Wrist
- 09 131 9904 Shoulder/Back

3 Pro-Tec Ice Cold Therapy Wraps

Effective ice cold therapeutic relief! Form fitting wrap remains flexible, conforming to your body. Ice therapy expedites recovery of muscle tightness and soft tissue injuries.

- 09 131 9870 Foot/Ankle/Leg/Knee/Elbow/Wrist
- 09 131 9888 Shoulder/Back

4 HeatBands™ Hand Warmers

HeatBands™ insulate the blood vessels close to the skin's surface at the wrist and reflect the body's own heat back into that area.

Raynauds Association approved. HeatBands™ Hand Warmers are ultra thin, lightweight wristbands designed to prevent cold hands without the use of drugs, chemicals or activation ingredients. HeatBands™ work by utilising the body's own heat. Each wristband has a waterproof outer surface and a skin safe absorbent inner with a heat reflective core. Neutral colour for discreet wear.

- 09 118 4761 Pack of 14
- 09 118 4779 Pack of 60

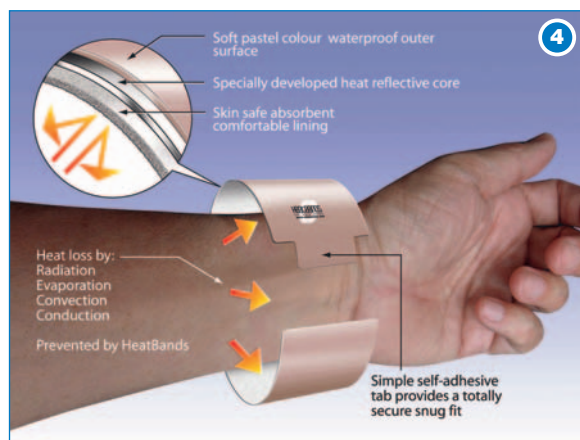
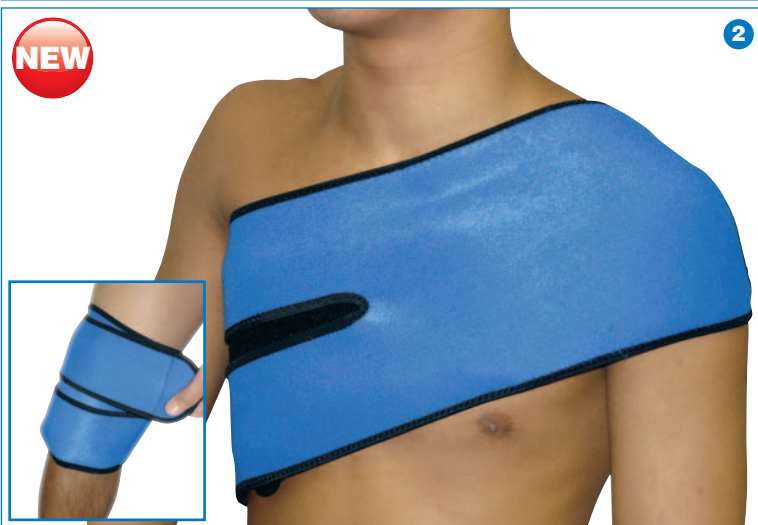

1



1 Ice Cuber

All stainless steel, free standing Ice Cuber, using the spray method which ensures hygienic and pure ice cubes all the time. The ice is stored in an easily accessible bin, maximum capacity 9kg. Dimensions: H 67cm x W 38cm x D 49cm. Production 21kgs. Storage 9kgs.

COL075

2 Scotsman™ Easy Ice Maker

A manual, injection moulded plastic ice cube maker produces hard, crystal clear, thimble shaped ice cubes. Over 24 hours the icemaker can produce 9kg of ice cubes (about 450 cubes). Ice cubes are stored in a bin with a capacity of 3.5kg (about 175 cubes). Dimensions: Height 640mm. Width 380mm. Depth 380mm. Weight 29kg. Fuse rating 13A. Average energy consumption 4.5kwh per 10 to 15 litres water at 15°.

No plumbing required.

AA9579A



3 Scotsman™ AF80 Ice Flaker

High quality ice flaker made from stainless steel. Produces small irregular flakes of ice, which have an even melting rate. Holding bin has 25kg capacity. It can produce 65kg flakes in a 24 hour period. Dimensions: Height 933mm x Width 535mm x Depth 621mm. Weight 72kg. Average energy consumption 7.5kwh per 64 litres water at 15°. Requires installation.

AA9579B Ice Flaker - Delivery Only

AA9579BI Ice Flaker - Delivery and Installation



2

SAME DAY DESPATCH



3



4 Chattanooga Chilling Unit

Large capacity and faster chilling time means your patients will never have to wait for a cold pack. The chilling units help you keep pace throughout a busy day. No plumbing required, simply plug into a standard electrical outlet.

- Mains Power - 220-240V, 60Hz
- 220V Unit

Chattanooga Chilling Unit Model C-2

CHA3014 84 x 53 x 41cm

5 Hydrocollator® Heating Unit

Hydrocollator Heating Units provide consistent heat for HotPacs. All units are made of stainless steel and are fitted with a thermostat to control the temperature of the unit. Low water sensor shuts off the unit if the water level gets too low. CE, UL Listed and cUL listed. Temperature range between 71-74°C.

Model SS2 Mobile

Versatility for the smaller department or clinic. Insulated tank. Height 84 x Length 53 x Width 39cm.

CHA2307 220V Unit

4



5



SDD UK SAME DAY DESPATCH
Delivered from stock. Please contact Customer Services for more information.

1 TheraFlex™ Re-usable Cold/Hot Packs

TheraFlex cold/hot packs are ideal for all clinical applications. Flexible when frozen, reusable and filled with a non-toxic, biodegradable gel. The wrapper is also recyclable. The packs are leakproof providing added safety for patients. Use also as a hot pack by either microwaving or by boiling in hot water.

- COL081** 27 x 12cm
- COL082** 32 x 15cm
- COL083** 30 x 9cm
- COL084A** 22 x 15cm
- COL085** 30 x 21cm

2 Colpac

These Colpacs remain completely flexible at any temperature down to -12°C. They are made from a strong vinyl that will understand any shaping or bending and will not become brittle or crack and leak.

Standard Colpac

- 004800** A 28 x 36cm

Half Size Colpac

- 004803** B 19 x 28cm

Quarter Size Colpac

- 004802** C 14 x 19cm

Neck Contour Colpac

- 004804** D 58cm long

Oversize Colpac

- 004806** E 28 x 53cm

3 Washable Hot Pack Covers

These multi-layered all terry cloth hot pack covers are soft and durable. Covers are not as stiff as the foam filled version and have the feel of a plush towel. All sizes are washable and fit corresponding Tropic Pacs.

- 923510** Standard 25 x 30cm
- 923511** Oversize 38 x 106cm
- 923512** Cervical 61 x 15cm

4 Terry Cover for HotPac

Constructed in a traditional terry knit weave, there is a cover to fit every size HotPac. Plus, they are washable.

Terry Cover For Oversize Hotpac

CHA1124

Terry Cover For Standard Hotpac

CHA1102

Terry Cover For Neck Hotpac

CHA1120

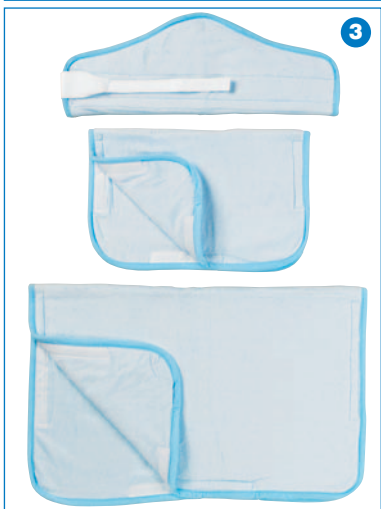
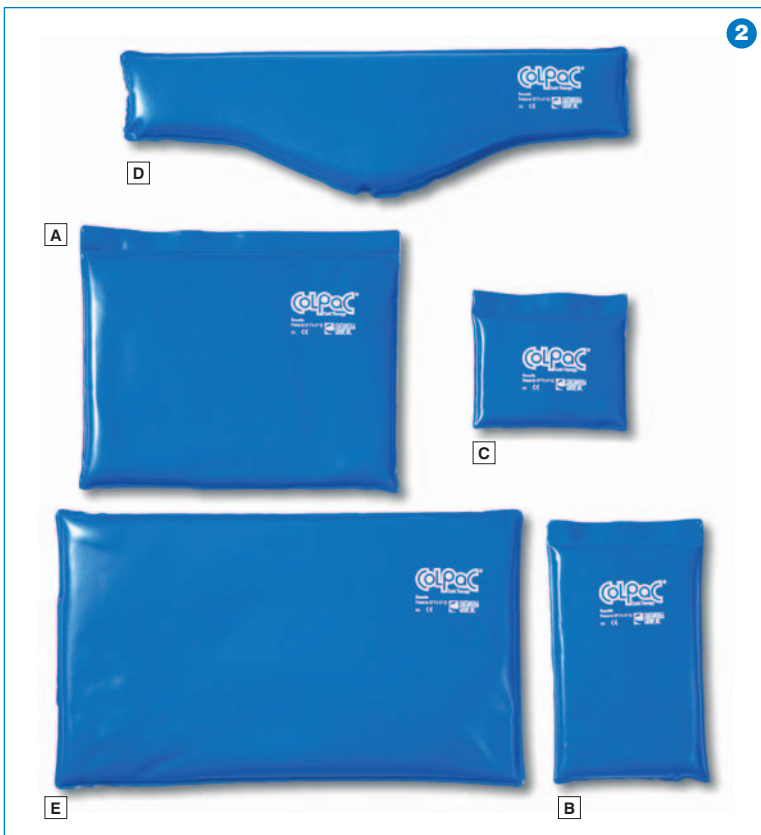

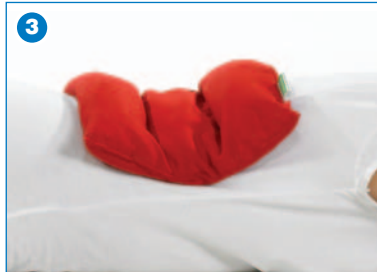
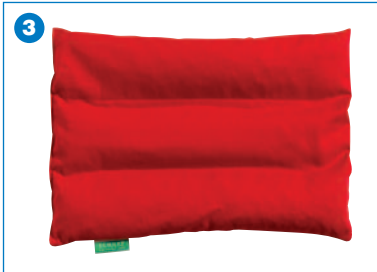
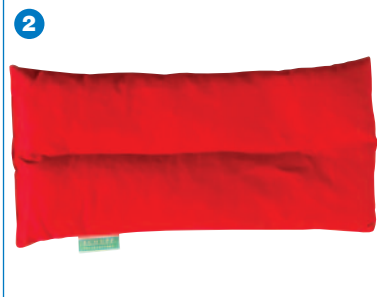

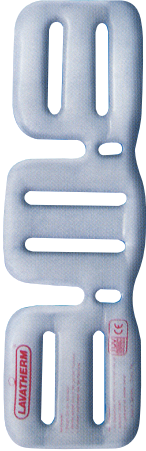

LAVATHERM®



SHOULDER & NECK PACK



BACK PACK



JOINT PACK

Cherry Stone Packs

Traditional method for moist heat / cold therapy massage treatment. The Cherry Stones store heat and have a longer heat storage capacity than most other natural methods. Rubbing the pack on the skin provides a massage effect promoting circulation.

1 Cherry Stone Pack

CHE10 Standard Size Pack 23cm x 23cm

2 Cherry Stone Pack Knee, Elbow and Ankle

CHE15 Knee, Elbow, Ankle 40cm x 20cm

3 Cherry Stone Back Pack

CHE20 Back Pack 40cm x 30cm

4 Cherry Stone Neck/Shoulder Pack

CHE25 Neck/Shoulder Pack

5 Lavatherm

The Lavatherm packs contain sodium acetate (a liquid salt), which is absolutely non-toxic and biodegradable. The packs are reusable for many years and are therefore a non polluting alternative to disposable packs and adhesives.

To use as a heat pack

- Approx. 54°C in one minute, without electricity and absolutely non toxic.
- Holds the heat approx. 2-3 hours.
- Reusable over many years, helping to save money.
- A big success with shoulder and neck bracing as well as back problems.
- Can be used any time, any place and are therefore ideal for people that are outside a lot or while travelling.

To use as a cold pack

Just put the Lavatherm in the refrigerator for about 20 minutes and it is ready to use. The great advantage is that due to the salt crystals the pack stays soft, supple, mouldable and adapts to every body-contour.

LAVA1020 Joint Pack 13 x 23cm

LAVA1040 Shoulder & Neck Pack 19 x 49cm

LAVA1060 Back Pack 43 x 27cm



Physio Med™

TOP QUALITY WHEAT PACKS

Our Wheat Packs have an inner lining and heavy duty removable and washable outer cover, manufactured from top quality corduroy.



**BEST
SELLER**

1 Top Quality Wheat Packs

- HOT400** Standard Relief Pack
- HOT450** Universal Pack
- HOT500** Back Relief Pack
- HOT700** Neck Relief Pack
- HOT750** Deluxe Cervical Relief Pack



FOOT



SHOULDERS



BACK



NECK



KNEE

1



1 Therabeads™ Microwave Moist Heat Packs

Have convenience and safety with these non-toxic, high quality microwavable heat packs. Therabeads conform to any contour, giving a soft, snug fit and do not saddle like many heat packs due to their superior construction. Made up of tiny hydroscopic beads, which retain their moisture for up to 30 minutes, and provide moist heat at the correct levels for effective therapy. Supplied with case. Therabeads are made from hydroscopic aluminium.

A61711	Half Size Pack	13 x 30cm
A61710	Standard Pack	23 x 30cm
A617100	Cervical Pack	17 x 56cm

2 Tropic Pac™ Moist Heat Packs

- To prevent mould and mildew growth
- Fabric prevents odours

Made of new synthetic fabric specifically designed to fight bacteria growth and its accompanying odour. Tropic Pac Moist Heat Packs apply moist heat for a minimum of 30 minutes. Packs are reusable.

09 100 5644	Standard	25 x 30cm	Single
09 100 5669	Half Size	13 x 30cm	Single
09 100 5685	Contour Cervical	61 x 15cm	Single
09 100 5701	Oversize	38 x 61cm	Single
09 100 5727	Knee/Shoulder	25 x 51cm	Single
09 100 5651	Standard	25 x 30cm	Pack of 12
09 100 5677	Half Size	13 x 30cm	Pack of 12
09 100 5693	Contour Cervical	61 x 15cm	Pack of 12
09 100 5719	Oversize	38 x 61cm	Pack of 4
09 100 5735	Knee/Shoulder	25 x 51cm	Pack of 6

2



3 IceOthem Pain Relief Pen

IceOthem is a small, hand-held, hyper-stimulating medical device that has been proven effective in temporarily reducing or eliminating pain. Apply the hot/cold IceOthem head to the point of chronic pain in your hands, elbows, feet, wrists, neck, back... anywhere you feel pain, for just a few minutes and experience relief for hours. IceOthem delivers quick relief from chronic pain caused by Osteoarthritis, Tennis Elbow, Chronic Tendonitis, Chronic Musculoskeletal Pain, Carpal Tunnel Syndrome, Plantar Fasciitis and more.

09 132 0225

3

NEW



INSTANT PAIN RELIEF

1 Therabath® Paraffin Bath Including Paraffin Wax

This heavy duty, hospital grade unit includes an energy efficient design with extra insulation; thermoplastic control to maintain a medically prescribed temperature; a safe melt system for 24 hour operation; a larger size to comfortably fit hands, feet, elbows and; CE/CETL listings for quality and safety. Includes 2.72kg (6lb) of triple filtered, therapeutic paraffin. Lifetime manufacturer's guarantee. 1 year Patterson Medical Warranty.

AA9713A Therabath with BS1363 UK Adaptor

AA9713B Therabath with EU CEE7 EU Adaptor



2 Therabath® Refill Paraffin Wax

With a medical grade blend which is then triple filtered for purity. Each carton contains 6 individually wrapped 454g packages.

AA9713C **A** Wintergreen

AA9713D **B** Scent Free

AA9713E **C** Lavender

09 132 0126 **D** Cucumber Melon

09 132 0134 **E** Rose Petal

3 Therabath® Mitt/Boot Liners

Plastic liners make paraffin treatment clean, fast and easy. Extra large size fits both hands and feet.

AA9713H Pack of 100

4 Terry Velour Mitts and Boots

Mitts and boots prolong heat from warm paraffin for longer lasting relief and softer, smoother skin. Made of heavyweight plush terry velour. Lined for maximum comfort and warmth, easy-to-use hook and loop closures, machine washable.

AA9713F Mitts - Pair

AA9713G Boots - Pair

5 Paraffin Beads

Rolyan

Paraffin wax and oils for professional use. Rolyan's paraffin wax is the purest, most refined paraffin in the industry. Since our paraffin wax is medical grade quality, it is extremely pure, which is evident by the clarity of the wax when it is in liquid form. Our paraffin wax and oil is available in four different scents as well as unscented. Formulated to not stick together. Sold in packs of 6. 454g bags.

A8192 Unscented Beads

6 Performa™ Insulation Garments

Terry cloth, machine washable wraps to prolong the therapeutic heat generated by paraffin treatments. The system consists of a plastic liner covered by an insulation mitt, boot or wrap (the wrap is great for elbow treatments). One size fits most adults.

A81983 Mitt

A81981 Boot

A81982 Wrap

A81980 100 Protective Liners



SPARES
Spares are available for these products, making them suitable for refurbishment. For full spares listing, please see pages 1353 to 1360.

1



BATH STAND WITH CASTORS

1 Combined Wax Steriliser and Wax

- Welded steel housing
- Welded aluminum vessel
- Energy saving insulation
- Removable lid with space for a ladle
- Thermostatic temperature control from 30°C to 85°C
- High temperature treatment 135°C
- Power on indicator

Outside measurements:

330 x 330 x 420mm

Inside measurements:

ø 250mm, height 300mm, capacity: 15 l, voltage: 230 V, 50 Hz heating capacity: 1000 W, temperature control: thermostatic, control accuracy: 2°C

WAB070 Wax Bath Only

WAB071 Wax Bath Stand with Castors
Height 64cm. Width 41cm. Depth 41cm

WAB072 Wax Bath Stand
Height 59cm. Width 41cm. Depth 41cm

2 30 Litres Wax Bath (Stainless Steel)

The inner tank is manufactured in stainless steel. The wax is indirectly heated by hot water, which offers the following advantages.

- Quicker heating
- More even heat distribution
- No temperature fluctuations in the wax

WAB060 Large Wax Bath
(30 Litres) 56cm x 45cm

2



3 Paraffin Wax

Paraffin Therapy provides optimal benefits for people suffering from arthritis, bursitis, sprains, tendonitis and joint stiffness. When heated and applied to the area of irritation, Physio-Med Premium Quality Unscented Wax has a soothing effect which relieves joint pain quickly and effectively. Available in 2.5kg or 5.0kg blocks with a melting point between 48° -52°C, this wax is recommended for use with any of the high quality baths in our range.

WAB040 5.0kg Block Paraffin Wax

3



Therapy Consumables

**BEST
SELLER**



- 322 - 324 Rolyan Band
- 325 - 327 Thera-Band
- 328 Rep Band
- 329 - 331 Therapeutic Putty
- 332 - 338 Hand Exercisers
- 339 - 340 Acupuncture
- 341 - 342 Paper Products/Couch Rolls
- 343 - 345 Protective Clothing/Gloves
- 346 - 353 Personal Hygiene & Cleaning Consumables
- 354 - 355 Scar Management
- 356 CCS Foot Care
- 357 - 362 Gehwol



Rolyan Band - Resistive Exercise Band

Incorporating
Cliniband

**PROGRESSIVE
RESISTANCE
COLOUR
SCHEME**



**BEST
SELLER**

Rolyan Energising Exercise Bands Rolyan

High quality exercise bands at great low prices. Progressive colour scheme is easy to remember without charts. Great for home or clinic use. Progressive resistive bands improve strength, range of motion and co-ordination.

5.5m Length	Colour	Weight
AA9860	Yellow	Light
AA9861	Red	Medium
AA9862	Green	Heavy
AA9863	Blue	X Heavy
AA9864	Black	XX Heavy

25m Length	Colour	Weight
003644	Yellow	Light
003645	Red	Medium
003646	Green	Heavy
003647	Blue	X Heavy
003655	Black	XX Heavy

46m Length	Colour	Weight
AA9865	Yellow	Light
AA9866	Red	Medium
AA9867	Green	Heavy
AA9868	Blue	X Heavy
AA9869	Black	XX Heavy



Exercise Band Dispenser Rolyan

A quality lightweight varnished wooden dispenser for Rolyan Band. It holds 5 large rolls, one of each colour, on front removing rotating spindles. Wall mountable (fixings included). Delivered flat packed, some light assembly required.

- S9988** Dispenser only
09 131 2867 Dispenser with all strengths of 46m latex band

Rolyan®

Energising Exercise BAND



**100%
LATEX
FREE**

**BEST
SELLER**



Rolyan Energising Exercise Bands – Latex Free

Rolyan

A complete range of resistive exercise bands which are 100% latex free, powder free, odour free and recyclable.

5m Length	Colour	Weight
EX-05	Yellow	Light
EX-10	Red	Medium
EX-15	Green	Heavy
EX-20	Blue	X Heavy
EX-25	Black	XX Heavy

50m Length	Colour	Weight
EX-50	Yellow	Light
EX-55	Red	Medium
EX-60	Green	Heavy
EX-65	Blue	X Heavy
EX-70	Black	XX Heavy

25m Length	Colour	Weight
XET141	Yellow	Light
XET142	Red	Medium
XET143	Green	Heavy
XET144	Blue	X Heavy
XET145	Black	XX Heavy

100m Length	Colour	Weight
EX-100	Yellow	Light
EX-110	Red	Medium
EX-120	Green	Heavy
EX-130	Blue	X Heavy
EX-140	Black	XX Heavy

1



Rolyan®

Energising Exercise
TUBE



2

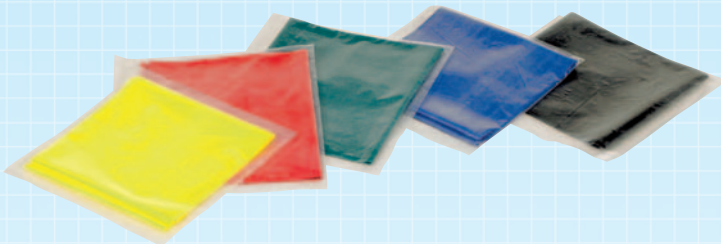

1 Rolyan Tubing

Colour coded tubing for varying degrees of resistance. Available in two lengths.

Length 762cm	Colour	Resistance
09 117 0315	Peach	Level 1
09 117 0331	Orange	Level 2
09 117 0356	Lime-Green	Level 3
09 117 0372	Blueberry	Level 4
09 117 0398	Plum	Level 5
Length 30.4m	Colour	Resistance
09 117 0323	Peach	Level 1
09 117 0349	Orange	Level 2
09 117 0364	Lime-Green	Level 3
09 117 0380	Blueberry	Level 4
09 117 0406	Plum	Level 5

2 Rolyan Bands Individually Packed

Individually packed Rolyan resistive exercise bands in 1.2m lengths. Available in singles or cases of 100.

Standard

Resistance	Single	Case of 100
Level 1	09 119 1949	09 119 2160
Level 2	09 118 1841	09 119 2178
Level 3	09 119 1956	09 119 2186
Level 4	09 119 1964	09 119 2202
Level 5	09 119 1972	09 119 2194

Latex Free

Resistance	Single	Case of 100
Level 2	09 118 1858	09 119 2129
Level 3	09 119 1980	09 119 2137
Level 4	09 119 1998	09 119 2145
Level 5	09 119 2004	09 119 2152

2





1 Thera-Band®

The Original and Number One Selling Exercise Band Worldwide.

6yds (5.5 metres) Dispenser Pack

XET049 Beige Extra Light

XET050 Yellow Light

XET055 Red Medium

XET060 Green Heavy

XET065 Blue Extra Heavy

XET070 Black Special Heavy

XET071 Silver Super Heavy

XET072 Gold Max. Heavy

50yds (45.5 metres) Dispenser Pack

XET075 Beige Extra Light

XET076 Yellow Light

XET077 Red Medium

XET078 Green Heavy

XET079 Blue Extra Heavy

XET080 Black Special Heavy

XET081 Silver Super Heavy

XET081A Gold Max. Heavy

2 Thera-Band™ Latex Free Not Illustrated

Thera-Band that contains no latex or natural rubber. Perfect for patient or therapist with latex or other sensitivities.

25m roll

	Colour	Resistance
92717900	Yellow	Thin
92717901	Red	Medium
92717902	Green	Heavy
92717903	Blue	Extra Heavy
92717904	Black	Special Heavy

LATEX FREE

3 Goggles

These strong, lightweight and flexible goggles conform to ANSI Z87.1+ standards.

GGP11UID Goggles



*Available for UK customers only, whilst purchasing Thera-Band products.



1 Thera-Band® Tubing

Thera-Band® exercise tubing available in various strengths. 7.5m / 30.5m lengths.

Tubing 7.5m

	Colour	Weight
21020	Yellow	Light
21030	Red	Medium
21040	Green	Heavy
21050	Blue	Extra Heavy
21060	Black	Special Heavy
21070	Silver	Super Heavy

Tubing 30.5m

	Colour	Weight
21110	Beige	Extra Light
21120	Yellow	Light
21130	Red	Medium
21140	Green	Heavy
21150	Blue	Extra Heavy
21160	Black	Special Heavy
21170	Silver	Super Heavy

2 Thera-Band® LOOP

Packed in boxes of ten, each Thera-Band® LOOP is individually packed with instructions for use. Available in 4 strengths and 3 sizes: 8" (20.5cm), 12" (30.5cm), 18" (45.5cm).

20810	Yellow	Light	8" (20.5cm)
20811	Yellow	Light	12" (30.5cm)
20812	Yellow	Light	18" (45.5cm)
20820	Red	Medium	8" (20.5cm)
20821	Red	Medium	12" (30.5cm)
20822	Red	Medium	18" (45.5cm)
20830	Green	Heavy	8" (20.5cm)
20831	Green	Heavy	12" (30.5cm)
20832	Green	Heavy	18" (45.5cm)
20840	Blue	Extra Heavy	8" (20.5cm)
20841	Blue	Extra Heavy	12" (30.5cm)
20842	Blue	Extra Heavy	18" (45.5cm)

3 Thera-Band® Patient Exercise Packs

Thera-Band® Patient Exercise Packs complete with 1.5 metres of exercise band and 16 page colour booklet covering 40 resistive exercises for both the upper and lower body.

PEP10	Yellow
PEP15	Red
PEP20	Green
PEP25	Blue

Thera-Band®

1 Thera-Band® Exercise Station

The Exercise Station was designed to integrate the use of progressive elastic resistance for strength training with exercise balls, fitness steps, and stability trainers. The station has a large centre cavity to fit Thera-Band® exercise balls and balance products. It has six pin connectors for resistive tubing attachments. The durable, high-impact polyethylene construction holds up to repeat use, while its granite colour blends in with most clinics and fitness facilities. The 10 rubber feet on the bottom keep it from slipping on hard surfaces. It is light enough to carry and is stackable to conserve space.

Kit comprises two each of Thera-Band® 30cm, 45cm and 60cm tubing in red, green and blue; an exercise bar, two Thera-Band® handles and two Thera-Band® Assist™ attachment devices, two stabiliser pads and one 65cm (blue) exercise ball.

21900

2 Thera-Band "Having Fun - Getting Fit" Kit

"Having Fun - Getting Fit" helps promote physical activity by offering pre-designed physical education programs for primary schools.

The program is ideal for children between the ages of 3 and 10. The lessons in the program target developing children's musculoskeletal system. They offer a range of exercises that can be adapted according to the varying ages and ability levels of the children. The kit includes:

Lesson Planner Book (12 Lessons)

1 x Cube/Dice

Box of Stickers

1 Set of Flash Cards

Thera-Band Resistance Bands

6 Thera-Band Green Bands (2.5 m)

6 Thera-Band Blue Bands (2.5 m)

4 Thera-Band Yellow Bands (2.5 m)

4 Thera-Band Red Bands (2.5 m)

10 Thera-Band Yellow Bands (1.5 m)

10 Thera-Band Red Bands (1.5 m)

Thera-Band Exercise Balls

6 Yellow 45 cm

4 Red 55 cm

Thera-Band Stability Trainer

2 green (light)

6 blue (heavy)

Thera-Band Soft Weights

2 Tan 1.1 lb. / 0.5 kg

3 Yellow 2.2 lb. / 1.0 kg

1 Red 3.3 lb. / 1.5 kg

09 142 3540



1 Rolyan Progressive™ Putty

One putty for a whole range of treatment needs. Begin with soft resistance, adding progress chips to gradually increase resistance. Putty resistance can be customised to fit individual needs. Ideal for home use - patients can progress independently. Eliminates the need to purchase putty in a variety of resistances. Non-oily putty. Base by itself is ideal for low resistance exercises. Non-toxic and latex free.

A478201 2.3kg (5lb) Putty Base with 32 Progress Chips

A478203 2.3kg (5lb) Putty Base without Chips

A478202 Pack of 4 additional Progress Chips

2 Sammons Preston Colour Change Putty

This non-oily, bleedproof speciality putty provides patients with visual feedback as exercises are performed. Squeezing, stretching or pinching the putty results in a gradual change in putty colour as its temperature increases. Putty will slowly revert back to original colour when not in use. Sold in multiple resistance packages of three 113g containers.

Colours (resistances) include: Orange/Yellow (Soft), Purple/Red (Medium-Soft), and Royal Blue/Light Blue (Medium). Latex free.

09 117 0414 Orange - Yellow Soft 4oz

09 117 0422 Purple - Red Medium-Soft 4oz

09 117 0430 Royal Blue - Light Blue Medium 4oz

09 103 6755 Set of 3

3 Rolyan Microwave Putty

Simply microwave, and putty will retain heat for 5 to 6 minutes. Resistance increases as it cools.

Colour	Resistance	Weight
09 105 0756 Orange	Soft	85g
09 105 0764 Teal	Firm	85g

4 Glitter Putty

This non-toxic putty contains bits of sparkling glitter to stimulate the senses while a child or adult manipulates it to improve hand function. Includes two containers of medium-grade resistance putty in pink and blue. Each contains 113g. Latex free.

920635



PROGRESSIVE RESISTANCE



SOFT ▶ ADDING PROGRESS CHIPS GRADUALLY INCREASES RESISTANCE ▶ HARD



COLOUR CHANGING

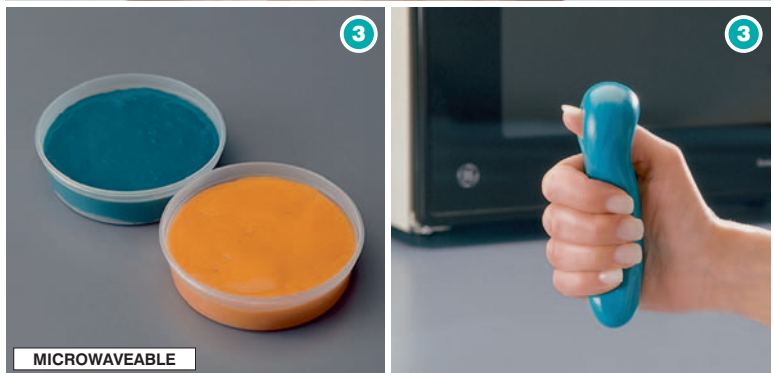

MICROWAVEABLE



GLITTER

Therapeutic Putty

1 Rolyan Putty Containers

These soft, plastic containers will not dent or break. Large quantities of putty can be bought and distributed to individuals this way, saving money. They are easy-to-open and flat enough to fit in a pocket. The lid features a label where client and therapist details can be recorded. Packs of 10.

A32810

2 Simply Putty®

Rehabilitation therapy for your hands. The Hygienic solution for single patient use putty. Each package contains one 2oz/50g portion of Simply Putty®, fresh and protected in a re-sealable foil package.

EX-600	Yellow	Soft
EX-605	Red	Medium/Soft
EX-610	Green	Medium
EX-615	Blue	Firm
EX-620	Flesh	Regular



3 Therapy Putty Hand Exercise Book

A 12 page booklet of hand exercises that can be performed with therapy putty. Written in layman's terms for client use. Ample room to add or change exercises to fit the client's needs. Pack of 20 booklets.

AA9043E	English
AA9043F	French
AA9043G	German

4 Mobilis Rolyan Therapy Putty

Clean, non-toxic, non-oily and bleedproof therapy putty leaves no colour or residue on the client's hands. It will not fragment, separate or stick to the skin. With six distinct colours to reflect established standards in resistive exercise, and progress in resistance from super soft tan to extra firm grey. Designed to meet a wide range of strengthening needs, putty can be squeezed, stretched, twisted or pinched. Combine any of the colours to create custom resistance to meet individual needs. Warning: avoid contact with materials eg. fabric, paper. Latex free.

Mobilis Rolyan Therapy Putty						
Weight	Super Soft Tan	Soft Yellow	Medium Soft Red	Medium Green	Firm Blue	Extra Firm Grey
57g	5065	5071	507199	5072	5073	929460
85g	929910	929911	929912	929913	929914	929915 £4.75
113g	506501	5074	5075	5076	5077	929461
454g	506502	507101	50719901	507201	507301	929462 £14.30
2.3kg	506503	507105	50719905	507205	507305	929463

Bulk Sets of 10 pk						
Weight	Super Soft Tan	Soft Yellow	Medium Soft Red	Medium Green	Firm Blue	Extra Firm Grey
57g	-	507110	50719910	507210	507310	-
113g	-	507412	507512	507612	507712	£50.65

5 Mobilis Rolyan Micro-Fresh™ Therapy Putty

With the addition of an anti-microbial agent called Ultra-Fresh, Micro-Fresh Putty will last longer than standard putty and provide odour protection. The incorporation of this anti-microbial agent enables the putty to resist the growth of destructive and odour-causing microbes. Ultra-Fresh is an EPA-registered anti-bacterial and anti-fungal agent. Micro-Fresh Putty is non-toxic, clean and non-oily. Designed to meet a wide range of strengthening needs for hands and feet: the putty can be squeezed, stretched, twisted or pinched. Five distinct colours reflect established standards in resistive exercise, but patients can also combine colours to create custom resistance levels. Latex free.

Mobilis Rolyan Micro-Fresh™ Therapy Putty						
Weight	Super Soft Tan	Soft Yellow	Medium Soft Red	Medium Green	Firm Blue	
57g	5181	5182	5183	5184	5185	£4.20
113g	518104	518204	518304	518404	518504	£7.10
454g	518101	518201	518301	518401	518501	£19.50
2.3kg	518105	518205	518305	518405	518505	£86.05



Clean
Non-Toxic
Non-Oily
Bleedproof



RETAIL PACKAGED
This product is supplied in Physio-Med retail packaging.

1



2



3



4



1



AUTOMATIC START

NSD Power® Ball

Introducing the unique new NSD PowerBall rehabilitation instruments

The definitive rehabilitation device...

Once activated, the NSD PowerBall generates levels of gyroscopic inertia previously unheard of for its small size. The smooth, fluid action of spinning your NSD PowerBall when coupled with this inertia results in a unique therapeutic quality which when used for 5-7 minutes per day will have a profound effect on:

- Carpal Tunnel Syndrome (CTS)
- Arthritis
- Repetitive Strain Injury (RSI)
- Wrist Injury/Break
- Tendonitis
- Tennis Elbow/Golf Elbow

Pure, Dynamic Therapy...

Recommended by Chiropractors, the NSD PowerBall is a fully dynamic rehabilitation product that takes your wrist through the actual ranges of its motion while simultaneously adding resistance.

Its unique 'non impact' properties gently stress damaged areas in a perfectly smooth and balanced manner which cannot be replicated by traditional exercise routines.

Results are produced quickly and efficiently and because the resistance generated by the ball is directly related to the speed at which you spin the internal rotor, you can use your NSD PowerBall at your own pace and without further risk of damage to existing inflamed areas.

1 NSD Power® Ball Auto Start

Auto Start: A spring loaded automatic starting mechanism makes this the most user friendly PowerBall. Comes complete with a built-in digital speed meter.

09 131 8138

2 NSD Power® Ball Classic

Classic: Loaded with a high performance 250Hz rotor.

09 118 9406 **A** Blue

09 118 9414 **B** Amber

3 NSD Power® Ball Pro

Pro: Loaded with a high performance 250Hz rotor, Pro models also come complete with an built-in digital speed meter.

09 118 9422 **A** Blue

09 118 9430 **B** Amber

4 Hand Grips

Resistive exerciser for advanced hand muscle strengthening. In pairs to exercise both hands simultaneously. 11cm distance between outside handle ends.

A8481 Medium Tension

A8482 Heavy Tension

A848003 Extra-Heavy Tension

2 **A**



2 **B**



3 **A**



3 **B**



4



1 Basic Ergonomic Hand Exerciser Rolyan

Provides progressive resistive hand strengthening. Conforms to the hand for comfort and even dispersion of resistance across the palm. Lightweight frame uses clips to block flexion and extension and permits a custom fit for different hand sizes. Includes three pairs of graded, colour-coded rubber bands, which can be changed to adjust resistance, and two clips. Replacement rubber bands below.

A3488 Each

Replacement Clips

A3486 Pack of 4

2 Ergonomic Hand Exerciser Rolyan

Conforms to the architecture of the hand for comfort and even dispersion of resistance across the palm. Anatomically designed handle is padded and contoured for a comfortable fit in the palm. The lightweight frame adjusts easily for blocking flexion and extension and permits a custom fit for different hand sizes. The unit includes four pairs of graded, colour-coded rubber bands. Replacement rubber bands below.

A3481 Each

Replacement Clips

A3486 Pack of 4

3 Colour-Coded Latex Free Rubber Bands Rolyan

85g packs of the graded colour-coded rubber bands used on the Rolyan Ergonomic Hand Exercisers. Each bag contains one colour. All rubber bands are 8.9cm long. 85g bag. Latex free.

Approx 134 in a bag.

	Colour	Width
A3482	Yellow	3.2mm
A3483	Red	6.4mm
A3484	Green	9.5mm
A3485	Blue	1.3cm

4 Thumb and Finger Exercisers

The Thumb Helper™ isolates IP joint movements of the thumb or single digits. Excellent for pinch and opposition exercises, the Finger Helper™ features a wider, two- and three-finger design to isolate IP and MP joint movements. Also ideal for children's and smaller hands. Stacking pegs allow ROM adjustment.

5246 Thumb Helper

5247 Finger Helper

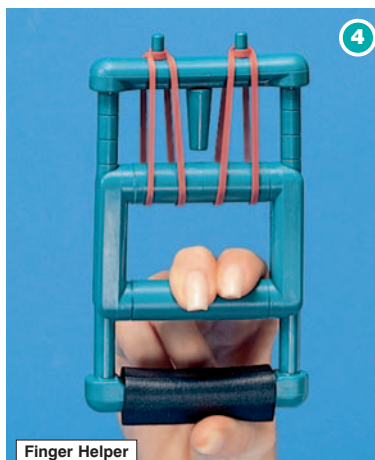
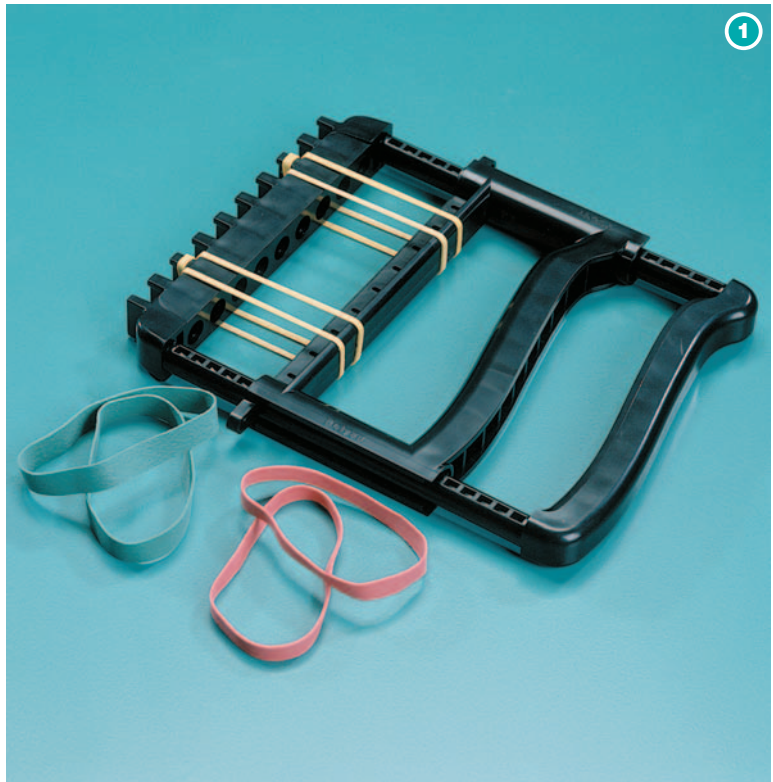

Finger Helper

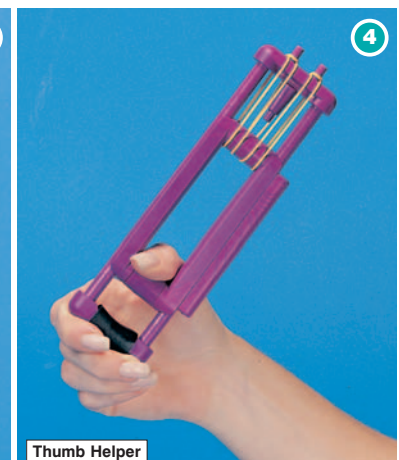

Thumb Helper



1 Digi-Block® Hand Exerciser Rolyan

Provides comfort and support as CMC, MCP, PIP or DIP joint motions are isolated and blocks undesired motion of the joints. Anatomically designed from firm foam, it is beneficial for increasing joint range of motion or strengthening specific muscles. Suitable for a wide range of hand sizes. Measures approximately 0.6 x 6 x 13cm.

A7147 Single
550963 12 Pack

2 Contour Hand Exerciser

Washable, vinyl-coated foam with finger placement indentations. Latex free. Small: 6.4 x 8.9 x 1.9cm. Medium: 7.0 x 10.2 x 2.5cm. Large: 7.6 x 12.1 x 2.5cm.

5316 4 of Each Size

3 Neo-G Hand Rehabilitation Exerciser

Contoured hand exerciser with finger placement indentations. Used to strengthen the hand and finger. One size and resistance.

09 117 0307

4 Handmaster™ Plus

Provides complete reciprocal muscle group exercise for the hand through full, natural planes of motion. It is recommended for improving strength, balance, coordination, speed, and general blood flow, stimulates all peripheral nerves to the hand and allows for unattended therapy. Designed for daily outpatient use to complement the treatment of hand, wrist, and forearm conditions. The Handmaster Plus is great for stroke rehabilitation, as well as the treatment and prevention of carpal tunnel syndrome, tennis elbow and RSI. Each package contains one resistant ball, two flexible cords (for varying hand sizes) and complete instructions.

	Colour	Resistance
929600	Purple for Early Rehabilitation	Soft
929601	Red for Late Rehabilitation	Medium
929602	Orange for Strength Training	Firm

5 Animal Squeezers

These fun-to-squeeze animals can be used for hand exercise and playing. The soft Animal Squeezers are made from high quality, slow-recovery polyurethane, which is both non-toxic and biodegradable. Latex free.

550824	Dolphin
550825	Alligator
550826	Cow
550827	Pig
550828	Horse
550829	Elephant
550830	Panda

6 Finger Platter

A multipurpose therapeutic exercise tool of durable, hard, rubber-like material. Use to treat adhesions, contractures, stiff fingers, arthritis, tendon injuries and repairs. Ideal for blocking exercises. Includes instruction manual. 12.5cm diameter. Latex free.

5264



1 R-Lite Resistive Foam Blocks Rolyan

Exercise blocks to help strengthen fingers and hands following injury or surgery. Ideal for use by people who have arthritis. Made of slow-recovery foam - the rate of exercise is determined by the foam's recovery time to help keep the overly enthusiastic patient from over using muscles. In three resistances for different strength levels and to allow progression. Blocks are 4.4 x 4.4 x 7.6cm. Wash in warm water with mild soap and air dry. Box of 32.

- A9085** Yellow (Super-Soft)
- A9086** Pink (Soft)
- A9087** Blue (Medium)
- 09 116 0480** Green (Firm)
- A9088** Set of 12 (3 blocks of each colour)



2 Gel Ball Hand Exerciser

Gel balls colour coded to provide variable resistance training for hands, fingers and forearms. The balls are pleasant to touch and return back to their original shape after each squeeze. Perfect for use in the clinic or at home.

	Colour	Resistance
AA9800	Pink	X-Soft
AA9801	Blue	Soft
AA9802	Green	Medium
AA9803	Orange	Firm
AA9804	Black	X-Firm
AA9805	Set of 5 - one of each colour	



3 Eggsercizer™

For strengthening weakened or injured hand, finger, wrist, and arm muscles. Completely washable in warm water. Contoured to fit comfortably into hand. Can be used to help reduce stress as well as increase strength and flexibility. Compressible synthetic rubber material leaves no messy residue. Returns to its original shape when released. X-Soft has slow recovery, great for individual finger and thumb strengthening. Colour coding simplifies progressive rehabilitation.

	Colour	Resistance
A90830	Orange	X-Soft
A90831	Green	Soft
A90832	Blue	Medium
A90833	Purple	Firm

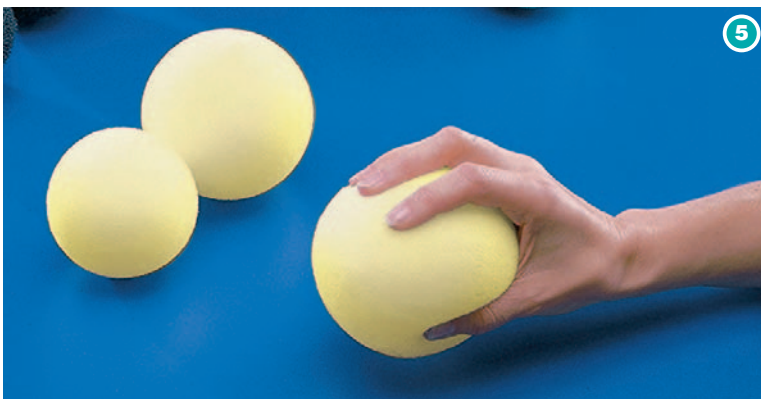

4 Squeeze Ball Hand Exerciser

Palm-size ball returns to its original 6cm diameter within 2 to 3 seconds after squeezing. A great tool for working off everyday stress too.

- 5302** Single
- 530212** Pack of 12

5 Tactile Foam Balls Set Rolyan

For hand range of motion, strengthening and desensitisation. Smooth surface. Includes three diameters: 7cm, 9cm and 14.5cm. **A4121**

6 Thera-Band® Hand Exercise

- Variable resistance training for hands, fingers and forearms
- Helps strengthen grip, increase dexterity and mobility
- Helps improve fine and gross motor skills
- Four colour-coded levels of resistance to meet a full range of patient applications
- Can be used for hot or cold therapy
- Comes with an illustrated manual that includes exercises developed by a licensed therapist

	Colour	Resistance level	Pounds of force to achieve 50% compression
XET1150	Yellow	Extra Soft	1½ pounds
XET1155	Red	Soft	3 pounds
XET1160	Green	Medium	5 pounds
XET1165	Blue	Firm	8 pounds
26099	Wooden Storage Box only		



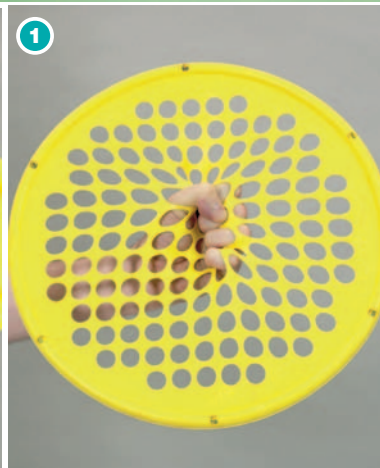
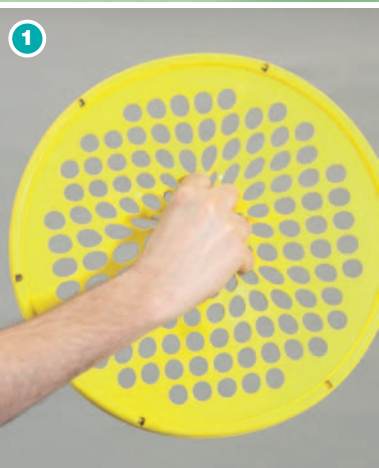

1 Cando® Hand Exercise Web

Flexion, extension, opposition and supination exercises can be performed using the Cando Hand Exercise Web. Excellent for improving strength and ROM. Resistance can be modified by adjusting the hand position, depth of finger insertion, or by moving to a different resistance web. Four versions are available: low-powder 35.5cm diameter; low-powder 17.75cm diameter; latex-free 35.5cm diameter; multi-resistance 35.5cm diameter.

	Type	Diameter	Colour	Resistance
AA9890A	Low-powder	35.5cm	Tan	XX-Light
AA9890B	Low-powder	35.5cm	Yellow	X-Light
AA9890C	Low-powder	35.5cm	Red	Light
AA9890D	Low-powder	35.5cm	Green	Medium
AA9890E	Low-powder	35.5cm	Blue	Heavy
AA9890F	Low-powder	35.5cm	Black	X-Heavy
AA9891A	Low-powder	17.75cm	Tan	XX-Light
AA9891B	Low-powder	17.75cm	Yellow	X-Light
AA9891C	Low-powder	17.75cm	Red	Light
AA9891D	Low-powder	17.75cm	Green	Medium
AA9891E	Low-powder	17.75cm	Blue	Heavy
AA9891F	Low-powder	17.75cm	Black	X-Heavy
AA9892A	Latex Free	35.5cm	Tan	XX-Light
AA9892B	Latex Free	35.5cm	Yellow	X-Light
AA9892C	Latex Free	35.5cm	Red	Light
AA9892D	Latex Free	35.5cm	Green	Medium
AA9892E	Latex Free	35.5cm	Blue	Heavy
AA9892F	Latex Free	35.5cm	Black	X-Heavy
AA9893A	Multi-Resistance	35.5cm	X-Light/Medium	
AA9893B	Multi-Resistance	35.5cm	Light/Heavy	

2 Cando® Flexible Hand Bar

A lightweight, portable exerciser to strengthen muscles in the hand, wrist and shoulder. Promotes co-ordination and increases ROM. The removable flexion band adds the ability to perform finger extensions. Can be used to perform oscillation movements for neuromuscular and balance training, and for soft tissue and joint mobilisation. Available in five resistances in five different colours. Length 30cm. Diameter 5cm.

	Colour	Resistance
AA9825T	Tan	XX-Light
AA9825Y	Yellow	X-Light
AA9825R	Red	Light
AA9825G	Green	Medium
AA9825B	Blue	Heavy
AA9825K	Black	X-Heavy



1 Thera-Band® Hand Trainer

Thera-Band® Hand Trainer will assist patients recovering from hand or wrist surgery, and help to improve strength and mobility. It follows the familiar Thera-Band® colour progression, which allows patients to easily track progress during treatment. Each colour-coded latex sheet, from tan to black, offers progressively more resistance for extension, flexion, and opposition exercises to improve grip strength and mobility.

- Six interchangeable levels of resistance from extra light to extra heavy
- Supplied in the familiar Thera-Band® colour progression

26200	Intro Kit
26210	Tan refill (6 sheets)
26220	Yellow refill (6 sheets)
26230	Red refill (6 sheets)
26240	Green refill (6 sheets)
26250	Blue refill (6 sheets)
26260	Black refill (6 sheets)



1

2 Thera-Band® Flexbar™

The Thera-Band® Flexbar™ is a lightweight and portable exerciser, it has been designed specifically to improve grip-strength and upper extremity function.

Applications:

- **Strengthening:** improve grip strength and upper extremity strength
- **Oscillation:** allows oscillation movements for neuromuscular training and balance training
- **Mobilisation:** provides soft tissue mobilisation and joint mobilisation

Three Levels of resistance:

Colour	Force required to bend 90°
Red	10 pounds / 4.5kg
Green	15 pounds / 6.8kg
Blue	25 pounds / 11.3kg

Supplied with application guidelines.

26100	Red - Light
26101	Green - Medium
26102	Blue - Heavy



1



1



2



2



2

1

NEW

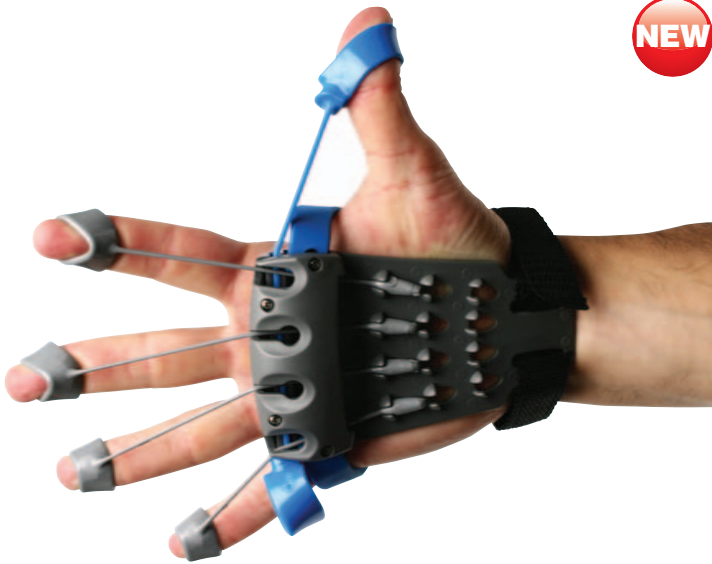

1 Xtensor™ Finger Extension Exerciser

This design is a break through, essential tool for therapists treating patients recovering from;

- Tendonitis in the wrist
- Overcoming the effects of a stroke
- Hand trauma rehabilitation
- Tennis elbow
- And much more!

The one-sided activity that is reflective of the work performed by the hands in everyday life can now be counterbalanced by the Xtensor™ with continuous tension applied to opening the hands, using an optimal line of motion replicating the exact opposite movement to closing the hands.

The Xtensor™ has three settings for varying difficulty and is supplied with two comfort pads. For smaller hands a third cushion pad is recommended. Available in yellow or blue.

09 131 9649 Blue

09 131 9664 Cushion Pad

2 Graded Pinch Exerciser

Rolyan

Designed for graded resistive exercise for increasing pinch strength and co-ordination. Features five different graded stainless steel springs in colour-coded pinchpins. The range of resistance is approximately 0.45kg, 0.9kg, 1.8kg, 2.7kg and 3.6kg. Three metal rods of different diameters accommodate the various openings of each pinchpin. Kit includes a vertical metal rod 95cm high for combining upper extremity shoulder range of motion exercises with resistive pinch exercises. Also includes a total of 35 graded spring pinchpins, 7 of each resistance. Height 22cm. Length 33cm. Width 32cm.

A1966

Replacement Graded Pinchpins - Set of 7

	Colour	Resistance
A196100	Yellow	0.45kg
A196200	Red	0.9kg
A196300	Green	1.8kg
A196400	Blue	2.7kg
A196500	Black	3.6kg

2



3 Digi-Flex™ Exerciser System

Develops isolated finger strength, flexibility and co-ordination as it builds hand and forearm strength. With this system, the stronger digits can no longer compensate for the weaker ones and each finger is appropriately challenged on its own spring-loaded button. Calibrated springs provide a quantitative tool for evaluating progress. White plastic rack display set consists of five pocket-sized, colour coded units with graduated resistances. Colour coding helps with quick identification and provides positive reinforcement with advancement from colour to colour. Includes pamphlet illustrating different methods of use.

	Colour	Resistance
A39715	Yellow	0.68kg
A3973	Red	1.4kg
A3975	Green	2.3kg
A3977	Blue	3.2kg
A3979	Black	4.1kg
A39710	Set of 5 with Display Rack	

3

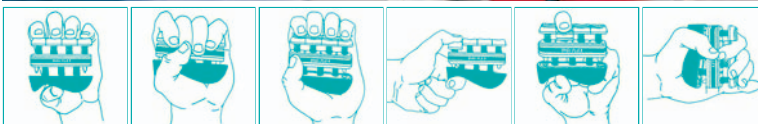

1 Classic Original Needles

This traditional silver plated copper based with looped end handle acupuncture needle is smooth, clean and nice to use. No guide tube. A shorter 7mm needle has been introduced for facial and ear acupuncture.

Thickness

ACC065A	0.18mm
ACC066A	0.20mm
ACC066B	0.20mm
ACC067A	0.22mm
ACC067B	0.22mm
ACC067C	0.22mm
ACC068A	0.25mm
ACC068B	0.25mm
ACC068C	0.25mm
ACC069A	0.30mm
ACC069B	0.30mm
ACC069C	0.30mm

2 IMS Plunger

This Stainless Steel Superior quality, tactile IMS plunger transforms an Acupuncture needle into a precision microsurgical tool. 50mm x 0.30mm Stainless Steel Acupuncture Needles (ACC 50) are recommended for use with this plunger.

IMS300

3 3 Channel Electro Acupuncture Unit

High Performance and Versatility.

- 3 independently controllable channels.
- Low/High frequency settings.
- Frequency range 1 - 500Hz.
- Unique wave pulse minimises excessive charge build up in the tissues avoiding nerve damage.

ACC115

4 ES-160: 6-channel Programmable Electroacupuncture

Try the various stimulation modes and preset programs available with this new model for cases that previously could not be cured by similar units due to their limited stimulation modes.

Features:

- Allows simultaneous stimulation with twelve acupuncture needles (6 channels)
- Provides 8 different stimulation modes such as Constant, Burst, Surge, Fast + Slow, Sweep, Random prog.1, Random prog.2, Random prog.3
- Saves parameters of the previous treatment and incorporates 16 free programmable memory settings
- Enables user to find and stimulate acupuncture points
- Allows measurement of Ryodoraku points and storage of the measurement data
- Environment-friendly electrode cords made of TPU.

Complete with standard accessories, including: 1 x LW-006 Search/Stimulation probe 6 x ZL-033MDD Electrode cord (6 colours) 12 x AC-100MDD Exclusive clips (6 colours, 6 red). **Note:** Batteries are not included.

ES-160



1



BEST SELLER



1 Classic Plus Acupuncture Needles

The most popular variety of acupuncture needle. Traditional coil and loop, copper handle, pain free insertion, silicone free and individual guide tube. Excellent value. Each size supplied in box of 100.

	Diameter
009773	13 x 0.20mm
221374	13 x 0.22mm
009774	25 x 0.20mm
09 116 2536	25 x 0.22mm
009775	25 x 0.25mm
221375	25 x 0.28mm
009776	25 x 0.30mm
011254	40 x 0.22mm
009777	40 x 0.25mm
221376	40 x 0.28mm
009778	40 x 0.30mm
221377	50 x 0.25mm
009779	50 x 0.30mm
09 116 2635	70 x 0.25mm
015341	70 x 0.30mm
221379	90 x 0.30mm

2



3 4



2 Dong Bang DB100 Needles

Spring handled needles packed with one needle per blister. With guide tube. 100 Needles per box.

		Length	Diameter
S2850	DB100	15mm	0.20mm
S2851	DB100	15mm	0.25mm
S2852	DB100	30mm	0.20mm
S2853	DB100	30mm	0.25mm
S2854	DB100	30mm	0.30mm
S2855	DB100	40mm	0.25mm
S2856	DB100	40mm	0.30mm
S2857	DB100	50mm	0.25mm
S2858	DB100	50mm	0.30mm

3 Seirin B Acupuncture Needle

Made of stainless steel and ground to diamond sharpness, polished three times and have a micro-thin silicone coating, making needle insertion particularly easy and gentle. Without guide tube. Box of 100.

010465	15 x 0.20mm	Blue
010466	30 x 0.30mm	Brown
010467	40 x 0.25mm	Violet
010468	50 x 0.30mm	Brown
010469	50 x 0.35mm	Black

5



6



4 Seirin J Acupuncture Needles

J-Type needles are ultra-fine and made of stainless steel, so that they only require slight pressure to penetrate the skin, achieved by gentle tapping. With guide tube. Box of 100.

009769	30 x 0.16mm
018717	30 x 0.20mm
018720	30 x 0.25mm
018719	40 x 0.20mm
009770	40 x 0.25mm
009771	50 x 0.30mm

5 Pre-Injection Swabs

Alco-tip swabs supplied in packs of 100 used for hygienic preparation.

09 116 2726

6 Instrument Trays

Used to keep your working environment safe and hygienic.

09 116 2668	Small	175 x 125 x 25mm
09 116 2676	Medium	225 x 175 x 20mm
09 116 2684	Large	370 x 270 x 50mm

7 Sharps Bins

09 116 2692	0.5 litres
09 116 2734	0.645 litres
09 116 2700	1.63 litres
09 116 2718	6 litres

7





1

1 Couch Roll

Available in 10" widths or 20" widths. Excellent quality 2 ply couch roll. 40 metres per roll. See table (right) for price/quantity break downs.
09 118 0264
09 118 0272

2 20" Plastic Backed White Couch Roll

The paper layer absorbs liquids, whilst the impermeable plastic layer prevents any liquids seeping through onto the couch or material below. This specialist couch roll is ideally suited to procedures or treatments where there is a risk of fluids penetrating regular paper only couch roll, contaminating the surface below. This couch roll allows absorption but not penetration.
COU-90 Plastic Backed Rolls

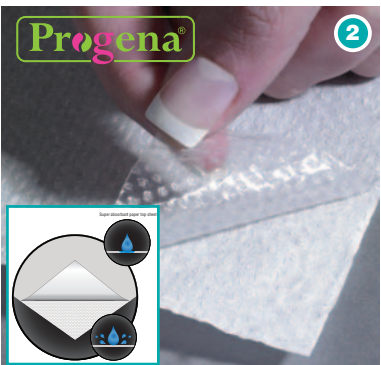

3 10" Wiper Roll

- 18 rolls per case
- 40m per roll
- 10" wide rolls
- Bright white or blue in colour
- Premium quality 2 ply tissue
- Easy tear perfect perforations
- 100% pure paper sourced from managed forests

COU-95WC White Rolls 18 Per case
COU-95BC Blue Rolls 18 Per case



4 10" Luxury Embossed Wiper Roll

- 18 rolls per case
- 32m per roll
- 10" wide rolls
- Bright white in colour
- Premium quality 2 ply tissue
- Easy tear perfect perforations
- 100% pure paper sourced from managed forests

COU-100 White Rolls 1-8 Rolls
COU-100C White Rolls case

5 Top Quality Couch Rolls Physio-Med

Available in 10" and 20" lengths.
MEF085 10" White 1-5 Rolls
MEF085B 10" Blue 1-5 Rolls
MEF080 20" White 1-5 Rolls
MEF080B 20" Blue 1-5 Roll

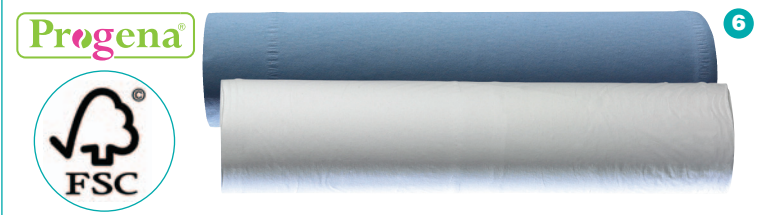

6 20" Luxury Embossed Couch Roll

- 9 rolls per case
- 32m per roll
- 20" wide rolls
- Bright white in colour
- Premium quality 2 ply tissue
- Easy tear perfect perforations
- 100% pure paper sourced from managed forests

COU-80 White Rolls 1-8 Rolls
COU-80C White Rolls case

7 Couch Roll Dispenser

Available in two sizes to house either a 10" or 20" couch roll. Can be wall mounted and makes dispensing couch roll very easy.
000269 20"
000270 10"





1 Cotton Wool Balls

Cotton Wool Balls. Non-sterile.
004112 Pack of 5

2 Cotton Wool BP Balls

Cotton Wool Balls. Sterile.
001682 Pack of 200

3 Cotton Wool Tip Applicators

007352 Pack of 100

4 Kleenex Hand Towels

Highly absorbent self presenting towels reduce consumption giving great value. 84 2-ply sheets per sleeve. Large.
001324 Pack of 116

5 Kleenex Medical Dry Wipes

005457 Pack of 76

6 Kleenex Boxed Tissues

This box contains 100 soft, 2-ply facial tissues made from 100% recycled fibre.
000272 100 tissues per pack

7 Paper Towel Holder

017520

8 Toilet Rolls

000271 Pack of 2

9 Medispat Tongue Depressors

Excellent value for money and designed not to split, these tongue depressors are available as standard or in spore-reduced packs for extra protection and safety.
AA98269 Standard
AA98268 Spore-reduced

1 Sterile Gown

Sterile gowns are available for all procedures and appointments.
005817 Large

2 Disposable Aprons

Disposable plastic apron protects clothing in any environment.
006924 Pack of 100 - White
006925 Pack of 100 - Blue

3 Mop Caps Non-Sterile

Available in blue.
018652 Pack of 100

4 Overshoe PVC Non-Sterile

Protects your shoes from spills and stains.
007361 Pack of 100 Green

5 Utility Drape

005802 75 x 90cm

6 Aperture Drape

005800 50 x 60cm Green

7 Clinical Waste Bags

09 142 1163 90 Litres (Large) 25pk
09 142 1171 Self Seal 100pk
09 142 1189 Medium (Size: 22 x 36") Roll 50

8 Contamination Polybags

007378 Pack of 200 Yellow

9 Kliniplast Sheet

005803 70 x 90cm - Non-sterile



1



2



3



4



5



6



7



8



9

1



1 Handsafe Powder-Free Latex Gloves

Box of 100. Natural

- 007905** Extra Small
- 007910** Small
- 007911** Medium
- 007810** Large

2 Handsafe Powdered Latex Gloves

Box of 100. Natural

- 007903** Extra Small
- 007904** Small
- 008767** Medium
- 007906** Large

3 Handsafe Powdered Vinyl Gloves

Box of 100. Natural. Latex free.

- 009514S** Small
- 009514M** Medium
- 009514L** Large

4 Handsafe Powder-Free Vinyl Gloves

Box of 100. Natural. Latex free.

- 009531S** Small
- 009531M** Medium
- 009531L** Large

2



3



4



1 INFORMATION
All gloves are EN4551, 2, 3 compliant.

1 Green Sterile Surgeon's Latex Powder Free Gloves

- 09 142 1197 Size: 6 Box of 50
- 09 142 1205 Size: 6.5 Box of 50
- 09 142 1213 Size: 7 Box of 50
- 09 142 1221 Size: 7.5 Box of 50
- 09 142 1239 Size: 8 Box of 50
- 09 142 1254 Size: 8.5 Box of 50
- 09 142 1262 Size: 9 Box of 50

2 Syntegra Sterile Surgeon's Polyisoprene Powder Free Gloves

- 09 142 1270 Size: 6 Box of 40
- 09 142 1296 Size: 6.5 Box of 40
- 09 142 1304 Size: 7 Box of 40
- 09 142 1320 Size: 7.5 Box of 40
- 09 142 1338 Size: 8 Box of 40
- 09 142 1346 Size: 8.5 Box of 40
- 09 142 1379 Size: 9 Box of 40

3 Nitrile Sterile Examination Powder Free Gloves

- 09 142 1395 Size: Small Box of 50
- 09 142 1411 Size: Medium Box of 50
- 09 142 1429 Size: Large Box of 50

4 Latex Sterile Examination Powder Free Gloves

- 09 142 1437 Size: Small Box of 40
- 09 142 1452 Size: Medium Box of 40
- 09 142 1460 Size: Large Box of 40

5 Masks

- 007353 **A** Pack of 100
- 007563 **B** Pack of 40
- 007354 **C** Pack of 50
- 005816 **D** Pack of 50



CLOVER CHEMICALS LTD

'Effective Cleaning Chemicals'



1 SAVON PEARLE Luxury Pearlished Hand Soap

A luxury, pearlished, pink liquid hand soap, designed to cleanse and condition the skin. Made from superior quality ingredients to produce a rich, mild foam, with a subtle rose fragrance. Suitable for use on all skin types. Ideal for use in washrooms, bathrooms and shower areas. Recommended for use in offices, health clubs, hotels, nursing and residential homes.

- 09 117 3624 6 x 300ml
- 09 117 3632 6 x 1ltr
- 09 117 3640 2 x 5ltr

2 BIO-DOX Bactericidal Hand Soap

A bactericidal hand soap and skin cleanser with a controlled foam level. A thick, clear, yellow liquid made from high quality surfactants and biocides, which is odourless and taint-free. Ideal for hospitals, nursing and residential homes.

- 09 117 3681 6 x 300ml
- 09 117 3699 6 x 1ltr
- 09 117 3707 2 x 5ltr

3 BARRIER CREAM Medicated Wet & Dry Barrier Cream

An advanced formulation Barrier Cream, which gives protection whilst replenishing the skin. A thick, pink cream made from a blend of skin emollients and conditioners, Barrier Cream is medicated to help prevent dermatitis. Effectively protects skin from cutting, fluids, oils, greases, aqueous detergents and cleaning fluids.

- 09 117 3749 6 x 300ml
- 09 117 3756 6 x 1ltr
- 09 117 3764 2 x 5ltr

4 Pumps and Dispensers

- 09 117 4366 Pump for 1ltr bottle
- 09 117 4358 Pump for 5ltr Bottle
- 09 117 4341 1 Litre Wall Mounted Soap Dispenser

5 UBIK 2000 Universal Cleaner

Universal cleaner and degreaser concentrate designed to dissolve and float away the toughest grime and leave a spotless finish. Ideal for removing fats, blood, dirt, industrial oils and grease from a multitude of surfaces including; concrete floors, industrial paintwork and painted floors, plastic walls and ceilings, ceramic tiles, plastic coatings, machinery and equipment, stainless steel and anti-slip floors.

- 09 117 3806 2 x 5ltr

6 AX Bactericidal Cleaner

A fast-drying, spray on and wipe off bactericidal cleaner for the food industry. AX has been proven to kill salmonella, listeria and other bacteria at a contact time of 60 seconds. It can be used to remove the daily soiling of grease and dirt. Suitable for general surface disinfection.

- 09 117 3830 2 x 5ltr

7 Arosa Air Freshener

A ready-to-use liquid air freshener incorporating a long lasting and distinctive floral fragrance.

- 09 117 3855 6 x 750ml
- 09 117 3863 2 x 5ltr

8 Fresh Wild Lemon Disinfectant/Deodoriser

A powerful disinfectant and deodoriser concentrate that kills odour producing bacteria and fungi and neutralises unpleasant odours.

- 09 117 3848 2 x 5ltr



Tested to kill:

- MRSA
- C-Diff
- E-Coli
- Salmonella
- Legionnaires
- NDM-1



1

1 Sterizar Hard Surface Cleaner

Sterizar is an antibacterial alcohol free hard surface cleaner. With advanced barrier technology, any surface treated with Sterizar will remain contamination free from any bacteria type for a minimum of 30 days. Tested food safe and tested to kill MRSA, C-Diff, E-Coli, Salmonella, Legionnaires plus 99.99% of other bacteria. Halal approved.

- 09 132 1405 **A** 750ml Fragrance Free
- 09 132 1413 **B** 750ml Lemon Scented
- 09 132 1421 **C** 5 ltr Fragrance Free
- 09 132 1439 **D** 5 ltr Lemon Scented



2

2 Sterizar Hand Sanitiser

Alcohol free hand foamers and hand wipes specially formulated to kill bacteria in seconds. The products give an immediate fresh and clean feel to the skin. It remains effective after application for at least 6 hours using advanced barrier control. No need to rinse and is kind to the skin. Tested to kill MRSA, C-Diff, E-Coli, Salmonella plus 99.99% of other bacteria. Halal approved.

- 09 132 1454 **A** 600ml Fragrance Free
- 09 132 1462 **A** 600ml Lemon Scented
- 09 132 1470 **B** 50ml Fragrance Free
- 09 132 1488 **B** 50ml Lemon Scented
- 09 132 1496 **C** Pack of 20 Wipes
- 09 132 4987 **D** Pack of 200 Wipes



1 Vernagel

This super absorbent powder prevents spillages, minimises residual odours and reduces the risk of cross-infection. It is designed to soak up bodily fluids, such as blood, vomit or urine, and can be used in a urine bottle before use or straight onto a floor spillage. Available as loose powder or in convenient sachets.

- AA98270** 4kg Loose Powder
- AA98271** 475g Loose Powder
- 09 116 5513** 100 x 6g Sachets

2 Guest Alcohol Hand Rub

This alcohol hand rub contains five hand-care ingredients to disinfect and moisturise the skin. Needs no water.

- 010368** 50ml - Toggle
- 010367** 500ml

3 Tuffie Disinfectant Wipes

Ideal for non porous surfaces where clinical cleanliness is required quickly and effectively. Proven effective against E.coli, MRSA and a range of other micro-organisms. Packaged in a container with foil seal. 200 per pack.

AA98273

4 Tuffie Detergent Wipes

Perfect for use anywhere where general cleanliness is required quickly and conveniently. They will remove dirt, grease and organic matter from lockers, mattresses, bed tables, beds and commodes without leaving residue. Packaged in handy size resealable 100 pack. Alcohol free.

AA98274

5 Chlor-O-Hex Spray

Chlor-O-Hex Spray offers fast disinfection of all hard surfaces including spitton bowls, surgery furniture and work tops. It can be used immediately for simultaneous disinfection and cleaning of hard surfaces and does not require wiping as it has rapid residue and free drying properties.

005942 450ml

6 Mediwipe Drum

Wipes for hard surface disinfection containing Chlorhexidine.

000814 Pack of 100

7 Hibitane Concentrate

For sterilisation of instruments. It can also be used as a general disinfectant of wounds or burns. Prolonged immersion of instruments will cause corrosion.

007754 5 Litre

8 Cidex OPA

Cidex OPA is designed for high level disinfection of heat-sensitive medical devices. It has a shelf life of 75 days from opening if left in the container.

009758 3.78 Litre

9 Presept Tablets

A handy powder-packed tablet, which when dissolved in water produces a solution ideal for instrument sterilisation and hard surface disinfecting.

006938 Pack of 72

10 Gigasept FF

A concentrate, which when diluted according to instruction is effective against all high risk micro-organisms. A solution remains potent for 28 days.

006734 2 Litre

Cutan®

The Cutan hand hygiene product range encourages best practice to achieve safe and acceptable levels of patient care, through the use of a 3-Step Hand Hygiene Procedure.

STEP 1: Hand Washing

1 Cutan® Gentle Wash

This high emollient content soap is ideal for frequent use. Its creamy formula spreads easily and lathers rapidly for high user acceptance to encourage frequent hand washing. Transient micro-organisms are gently removed with the mild surfactant base that is designed to minimise skin drying without compromising cleaning ability. Non-toxic with pH neutral to lessen impact on skin, even with frequent use. Supplied in a hygienic ultra-sonically sealed 1 litre cartridge for exclusive use in Cutan 1000 Gentle Wash Dispenser.

AA98129 Case of 6

AA98137 Cutan Gentle Wash Dispenser

STEP 2: Hand Sanitising

2 Cutan® Foam Hand Sanitiser

A unique, high efficacy foaming alcohol skin sanitiser that works instantly to kill micro-organisms present on the skin. Foam spreads easily across the hands for maximum efficiency and will not run through fingers like traditional alcohol rubs. Quick and easy to use with no need to rinse with water or dry with towels. Available in a range of pack sizes: a hygienic ultra-sonically sealed 1 litre cartridge for exclusive use in Cutan 1000 Hand Sanitiser Dispenser; plus portable pump packs for bed-end systems and personal issue pumps.

AA98130 1 Litre Cartridge Case of 6

AA98138 Cutan Hand Sanitiser Dispenser

AA98131 400ml Portable Pump Case of 12

AA98140 Cutan 400ml Hand Sanitiser Bracket

AA98132 50ml Personal Issue Pump Case of 25

3 Cutan® Gel Hand Sanitiser

A quick, easy and convenient method to rapidly disinfect physically clean skin. Formulated with ethyl and propyl alcohols for mildness, efficacy and relatively low odour and contains conditioning agents to help maintain good skin condition. Quick and easy to use with no need to rinse with water or dry with towels. Available in a range of pack sizes: a hygienic ultra-sonically sealed 1 litre cartridge for exclusive use in Cutan 1000 Hand Sanitiser Dispenser; plus portable pump packs for bed-end systems and personal issue pumps.

AA98133 1 Litre Cartridge Case of 6

AA98138 Cutan Hand Sanitiser Dispenser

AA98134 400ml Portable Pump Case of 12

AA98140 Cutan 400ml Hand Sanitiser Bracket

AA98135 50ml Personal Issue Pump Case of 48

STEP 3: Skin Conditioning

4 Cutan® Moisturising Cream

Specifically developed for use in healthcare environments, the non-ionic cosmetic formula is ideal for areas where chlorhexidine based skin sanitisers are in use. The mild, neutral pH formula is gentle on the skin leading to high levels of acceptance. It rubs in quickly and easily, leaving no greasy after-feel, and regular use helps maintain skin condition. Supplied in a hygienic ultra-sonically sealed 1 litre cartridge for exclusive use in Cutan 1000 Gentle Wash Dispenser.

AA98136 Case of 6

AA98139 Cutan Moisturising Cream Dispenser



FREE
DISPENSERS
WITH CUTAN
HAND HYGIENE
RANGE

Dispensers are only compatible with the Cutan range above and are available free of charge with purchases from the range.



Advanced Decontamination Technology

1 Ebiox Ultra P - Surgical Instrument Cleaner

Super concentrated powder which quickly dissolves in warm water. Safe to use, polymer-based solution cleanses to molecular level, surgical instruments and high stick surfaces which need to be surgically clean. Used as a soak and rinse, in ultrasonic baths or spray and wipe. Lasts up to 16 hours when mixed. It is aldehyde, chlorine, enzyme and phenol free which reduces to risk of skin infections. 20g dilutes into 2 litres of water.

004243 600g

09 131 9292 5kg

2 Ebiox Neozyme - Instrument Decontamination

This enzymatic foam spray inhibits the 'hardening' of the biofilm onto the surface of soiled surgical instruments, keeping them moist during transit to the decontamination facility. Breaks down protein, body fluid, blood, fat and carbohydrates. Keeps soiling moist reducing the rewash rate. Safe and pleasant to use.

09 131 9342 500ml

3 Ebiox Ultra L - Surgical Instrument Cleaner

A liquid concentrate detergent which is suitable for use in automatic spray and ultrasonic washer disinfection machines. Cleans surgical instruments to the molecular level removing tissue residues, fluids and other pathogenic debris. Proven to remove biofilms, particularly effective on difficult instruments penetrating crevices and burrs. Safe to use on stainless steel, aluminium and plastics.

09 131 9300 5ltr

09 131 9318 10ltr

4 Ebiox Ultra RDA - Rinse and Drying Aid

A liquid concentrate rinse and drying aid for injection into the final rinse water in spray and ultrasonic washer machines. Satisfies the demand for zero spotting reducing the rework rate. Inhibits the formation of crystals and sheds water off cleaned instruments. Inhibits 'sticky' joints. Safe to use on stainless steel, aluminium and plastics.

09 131 9326 5ltr

09 131 9334 10ltr

5 Ebiox Ultra SSC - Surgical Steel Reconditioning

Removes stains, 'rust' marks and dull shadow from the surface of surgical instruments and stainless steel. Ideal for reconditioning the damaged surface of surgical steel and reforming the bright protective metal film.

014781 100g



Advanced Decontamination Technology



1

NEW



2

NEW



3

NEW

1 Esense Hand Wash
 Non-alcohol based. Chlorhexidine and triclosan free. Complies with EN1499 and prEN 12054. Highly effective anti-microbial protection. Contains moisturisers leaving hands feeling soft and conditioned. Promotes healthy skin. Active ingredients: Polyhexamethylene Biguanide and Cocamidopropylbetaine.
09 131 9359 800ml with dispenser
09 131 9367 800ml refill

2 Esense Hand Foam Rub
 Antimicrobial foaming hand rub. Mild, non alcohol based solution. Fully compliant to European efficacy standards EN1500, EN 12054 and EN 14476. Safe to use, easy to dispense. Drying time allows maximum contact time to maximise efficacy utilising the Ayliffe technique. Offers effective protection against cross infection. Non flammable. Chlorhexidine and triclosan free. Low skin irritancy properties. Highly effective anti-microbial protection.
09 131 9375 800ml with dispenser
09 131 9383 800ml refill

3 Esense Hand Lotion Rub
 Mild, non-alcohol based lotion. Low skin irritancy properties. Complies with EN 1500 and prEN 12054. Highly effective anti-microbial protection. Contains moisturisers leaving hands feeling soft and conditioned. Excellent properties as a hand rub or cream. Helps support and maintain skin integrity.
09 131 9391 800ml with dispenser
09 131 9409 800ml refill

Ebiox Trionic
 Trionic multi-surface decontamination wipes and ready to use spray provide an alcohol free solution to clean, deodorise and disinfect any washable surface and are proven effective against a wide range of micro-organisms including MRSA and E. coli*.
 • Alcohol free - can be used on any washable surface
 • Total cell removal - no residual organisms left to develop into resistant strains
 • Proven against a wide range of micro-organisms*
 • Provides broad spectrum, anti-microbial activity
 • Bactericidal, fungicidal and virucidal
 • Safe, convenient and pleasant to use
 * Independent Test Hospital Infection Research Laboratory. Further information is available on request.



4



5

4 Ebiox Trionic Concentrate
014782 5 litre

5 Ebiox Trionic Spray
014779 500ml

6 Ebiox Trionic Wipes
014780 Pack of 200

7 Ebiox Trionic Hand Toggle
017951 50ml



6



7

1

NHS Approved

NEW

clinell® Sanitising Products

1 Clinell® Antibacterial Hand Wipes

Contains a unique, patented biocidal formulation which kills 99.999% of germs and bacteria within 10 seconds and then remains effective for a further 72 hours! These wipes come in convenient small sachets and contain moisturisers and aloe vera which is kind to the skin and safe to use on children's hands. Alcohol free. Proven to kill MRSA, Staphylococcus Aureus, Listeria, Salmonella, HIV, Herpes, Influenza, Hepatitis B and C and Norovirus within 10 seconds!

Tested to European standards EN1276, EN1500 and prEN 12054. Dermatologically tested. 100 wipes per box, wipe size 20 x 20cm, sachet size 6 x 8cm.

09 131 9417

2 Clinell® Hand and Surface Sanitiser

Contains a unique, patented biocidal formulation which kills 99.999% of germs and bacteria within 10 seconds and then remains effective for a further 72 hours! Available in a 60ml hand spray or a 500ml surface sanitiser. It does not contain bleach so surfaces are safe to use immediately after use in areas such as food preparation. No soap or water needed to sanitise hands. Dermatologically tested and is alcohol free.

Proven to kill MRSA, Staphylococcus Aureus, Listeria, Salmonella, HIV, Herpes, Influenza, Hepatitis B and C and Norovirus within 10 seconds!

09 131 9425 Hand 60ml

09 131 9433 Surface 500ml

3 Clinell® Chlorhexidine Wash Cloths

Ideal for use before entering a hospital. This wipe provides rapid antibacterial action and long lasting protection, helping to reduce harmful skin bacteria. Can be microwave heated to give greater patient comfort. Supplied in individual patient packs with 4 wipes in each pack. Wipes perform three functions; clean, disinfect and moisturise.

Contains 2% Chlorhexidine. Lanolin and alcohol free. Tested to EN1276 and skin neutral of pH5.5. Large wipe size 30 x 20cm.

09 131 9441 1 patient pack

09 131 9458 12 patient pack

4 Clinell® Bedbath Patient Bathing Wipes

No need for traditional bedbath methods! These large washcloths 30 x 24cm ensure a consistent coverage. Reduces laundry bills and no towel drying. Wipes can be warmed in a microwave to give greater patient comfort.

Supplied in individual patient packs containing 10 wipes per patient which prevents infection being passed from one patient to another.

09 131 9466 1 patient pack

09 131 9474 24 patient pack

2

NHS Approved

NEW

3

NHS Approved

NEW

4

NHS Approved

NEW

clinell
Sanitising Products

Therapy Consumables

1 Clinell® Universal Sanitising Wipes

Contains a unique, patented biocidal formulation which kills 99.999% of germs and bacteria within 10 seconds and then remains effective for a further 72 hours! This wipe is a disinfectant and detergent in one, no need for several different types of wipes and surface cleaners. Can be used to clean hands, surfaces and equipment. These wipes are proven to kill MRSA, Staphylococcus Aureus, Listeria, Salmonella, HIV, Herpes, Influenza, Hepatitis B and C and Norovirus within 10 seconds! Tested to EN1276 and prEN 12054. Available in 5 pack sizes.

- 09 131 9482 40 wipes
- 09 131 9490 100 wipes
- 09 131 9508 140 wipes
- 09 131 9516 200 wipes
- 09 131 9524 225 wipes

2 Clinell® Detergent Wipes

Detergent wipes provide an ideal choice for multi-surface general cleaning and damp dusting. Specifically formulated to thoroughly remove dirt from hard surfaces, the wipes offer a convenient and effective way to clean prior to disinfection. You can use detergent wipes on all surfaces, such as; taps, door handles, mattresses, tables, desks, keyboards, chairs, trolleys, lockers, bed frames and toilet areas. Contains 0% alcohol or disinfectant. Available in 3 pack sizes.

- 09 131 9532 100 wipes
- 09 131 9540 200 wipes
- 09 131 9557 225 wipes

3 Clinell® Sporidical Wipes

The safe alternative to chlorine, this is the only peracetic acid generating wipe in the world, which is activated just by adding water. Kills C-Diff within 1 minute with a greater than 6 log, ideal for cleaning any surface where C-Diff or other micro-organisms are suspected or proven to exist. Can be used for cleaning up blood and other bodily fluids, effective at killing spores in highly soiled conditions such as faeces. Kills all know germs and bacteria. Supplied in a dry state so it can't dry out, just add water, no need to dilute. Does not emit any toxic fumes and is environmentally friendly.

- 09 131 9565

4 Clinell® Accessories

A range of wall mounted dispensers are available and tape to seal off areas which have been cleaned.

Wall mounted metal dispenser for Clinell Universal Sanitising Wipes 100 Tub

- 09 131 9573

Wall mounted metal dispenser for Clinell Detergent Wipes 100 Tub

- 09 131 9581

Wall mounted plastic dispenser for Clinell Universal Sanitising Wipes 200 and Clinell Detergent Wipes 200

- 09 131 9599

Clinell Tape 3.8cm x 100m 12pk

- 09 131 9607





CLINICAL RESULTS

Scar Treatment

A total of 47 hypertrophic scars in 42 patients, most of them due to burns, were divided into treated and control areas. Improvement in scar appearance at 2 months.

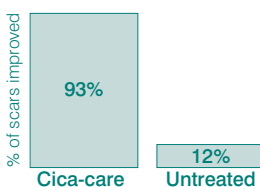

Improvement in scar appearance at 2 months

1 Cica-Care™ Silicone Gel Sheets

A revolution in Scar Management. To reduce appearance of scar. Improves patient self esteem. Improves movement and function of scar.

Extraordinary adhesive action

- No need for tape or bandages
- Painless to remove and easy to replace
- Can be used where pressure cannot be applied

Single sided reinforcing membrane

- Prevents gel from crumbling so sheet lasts longer
- Can be washed and re-used to reduce possible incidence of skin irritation

Release liner

- Quick and easy application
- Helps reduce hypertrophic and keloid scars

For use over closed wounds. To apply, simply cut a sheet to fit scar, peel off protective backing and position gel. For larger scars, several sheets can be used side by side. Release liner allows simple and quick positioning on the required site. Sterilised individually. Sheet size 15 x 12cm (6 x 4^{3/4}”).

66250707 Pack of 10 sheets

66250706 Single sheet

2 50/50 Mix™ Elastomer Putty

Rolyan

Use equal proportions of blue putty base to white putty catalyst for consistent work/set times. 50/50 Mix leaves no oily residue on hands while mixing. Each kit comes with convenient measuring scoops. Store at or below 23°C.

A9581 240g Kit

A9582 847g Kit

3 Ezemix™ Elastomer Putty

Rolyan

Instructions illustrate how to judge exact amount of elastomer needed prior to adding catalyst and how much catalyst to use. Thick putty is ideal over areas where gravity is a concern. Kit includes gel catalyst.

A9591 220g Kit

A9592 858g Kit

A9593 20g Extra Catalyst

4 Dermatix Silicone Sheet - Fabric

The fabric sheets are thin, self-adhesive and fabric backed. It is lined on one side with silicone, which sticks to the skin reducing and preventing scars. The other side is lined with silky-smooth fabric, which makes Dermatix silicone sheet comfortable and convenient to use under clothing. Dermatix Silicone Sheet Fabric can be washed with mild soap and water, making Dermatix silicone sheet reusable and easy to care for.

09 118 6303 4 x 13cm

09 118 6329 13 x 13cm

09 118 6378 13 x 25cm

09 118 6394 20 x 30cm

5 Dermatix Silicone Sheet - Clear

Made from silicone and PTFE, the thin Dermatix Silicone Sheet Clear provides a unique combination of transparency, flexibility and adhesiveness. The silicone reduces and prevents hypertrophic scars and keloids, while the transparency offers minimal visibility of the sheet. Dermatix Silicone Sheet Clear does not require adhesive aids such as tape or netting, making Dermatix silicone sheet ideal for wearing on the face or hands. Dermatix Silicone Sheet Clear can be washed with mild soap and water, making Dermatix silicone sheet easy to reuse.

The benefits of Dermatix Silicone Sheets

- Convenient and easy to use
- Transparent (clear) or silky fabric for optimal level of comfort
- Indicated for use on children
- Indicated for use on patients with high risk of scarring
- Self-adhesive and convenient
- Thin and pliable
- Durable and washable
- Semi-permeable

09 118 6204 4 x 13cm

09 118 6212 13 x 13cm

09 118 6253 13 x 25cm

09 118 6246 20 x 30cm

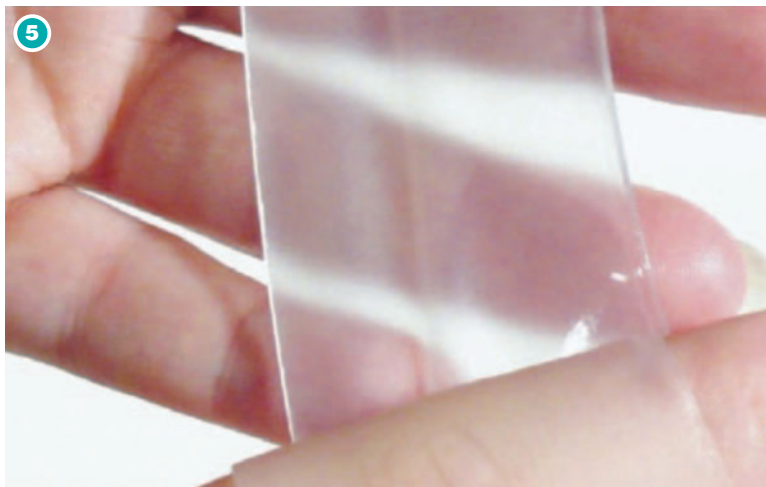

1 Mini Massager

Compact but powerful massager includes three heads for concentrated massage of specific areas. Cap can be left on for massage over larger areas. Battery operated massager vibrates at approximately 5500 cycles per minute. Battery included.

AA9200A

2 Scar Pump

Use following tendon repair, grafting, when skin adhesions limit motion, or, when active motion, light resistance and scar massage are appropriate treatment methods. Latex free.

A8391

3 Digital Caps

Elastic and mesh caps lined with Silipos polymer gel for scar management, digit amputation and hypersensitivity. Can be cut to size. For use on the fingers or toes.

Mesh

AA942406 8 per pack

Ribbed Knit Fabric - Packs of 6

AA942407 Mini - per pack

AA942408 Ribbed Small/Medium

AA942409 Ribbed Large/X-Large

4 Gel Tubing

Similar to digital caps but allow fingertips to be free for function.

Mesh

AA942410 Narrow

AA942411 Wide

Ribbed Knit Fabric

AA942412 Narrow

AA942413 Wide

5 Gel Tubes

Elastic tubes lined with polymer gel padding are worn over an injured or malformed digit or limb to provide gentle compression and lubrication of skin. The tube protects by absorbing friction and conforming to the area evenly. Softens dry or injured skin. Excellent for partial finger amputations to lessen sensitivity, while having a therapeutic effect on scar site. Can be turned inside out and placed on finger or writing utensil as a writing aid.

Cut to any length. Hand wash, air dry.

AA4572A Small 70cm Roll

AA4572B Medium 70cm Roll

AA4572C Large 70cm Roll

6 Digital Pads

A soft elasticated sleeve with a disc of gel containing mineral oil to soften and lubricate skin. Ideal for scar management and to protect against pressure and friction on blisters, corns, hammertoes, calluses, etc. Hypoallergenic and washable.

AA4502A Small Pack of 3

AA4502B Medium Pack of 3

AA4502C Large Pack of 3

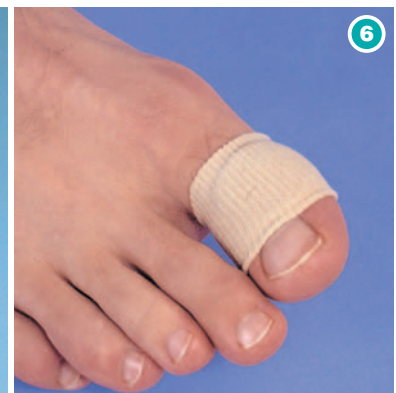
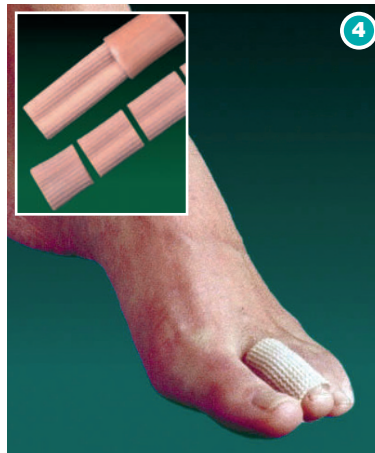
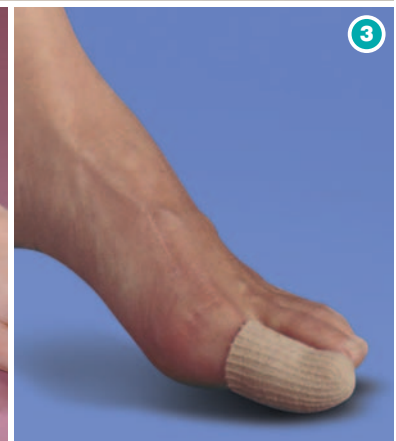



Benefits: • Suitable for diabetics • Excellent for dry skin • Non greasy

1 CCS Foot Care Cream

CCS Foot care cream is extremely effective in the control of dry skin and cracked heels. It contains 10% urea, the body's natural moisturiser which helps the skin to retain moisture and soften calluses and dry skin. It also contains bacteriacides and is lanolin free and hypo-allergenic. Recommended for Diabetic use.

016306	60ml tube
016303	175ml tube
016304	1kg tub refill
016301	1kg tub with pump

2 CCS Heel Balm

CCS Heel Balm is especially formulated to help control the most difficult case of rough, dry cracked heels. Contains Urea (25%) the body's natural moisturiser and a high concentration (50 iu/g) of the anti-oxidant Vitamin E. Fast acting and able to exfoliate the skin without the need for pumice, CCS Heel Balm strengthens and balances the texture of the skin and shields it with a non greasy protective barrier. Lanolin Free and recommended by Diabetes Advisors.

016300	75g
---------------	-----

3 CCS Foot Bath Salts

CCS Foot Bath Salts are effective in the control of dry and rough skin. This treatment foot bath is ideal for softening hard thick skin as part of a regular foot care routine. The 100% Urea formula dissolves easily in water, softens skin and also helps feet feel fresh. Easy to use doses.

018979	5 x 15g
---------------	---------





1 GEHWOL® Footcream

For strained feet and highly stressed skin.

Prevents sores and blisters

Gerlach's GEHWOL FOOTCREAM prevents aching feet, sores, blisters, soreness and chafing. It has an anti-inflammatory effect, prevents infections and brings the activity of the perspiratory glands back to a normal level.

The cream eliminates foot odour and other side effects of excessive foot perspiration. GEHWOL FOOTCREAM strengthens the skin and makes it resistant.

Protects amputation stumps and hands during strong strain. In addition, the foot cream offers protection against cold feet and frostbite. Gerlach's GEHWOL FOOTCREAM has been established since 1882 and is scientifically proven to treat aching, sore feet. Gerlach's GEHWOL FOOTCREAM has successfully been used a million times over to treat overstrained feet.

09 131 7858 75ml Tube

2 GEHWOL® Extra

Universal foot cream with broad-spectrum efficacy.

For daily intensive care

GEHWOL EXTRA intensively cares and strengthens overstrained feet. The skin of the feet is deodorised and disinfected. GEHWOL EXTRA protects against sore feet, infections, foot odour, calluses, sores and blisters and makes dry, rough skin smooth. Natural GEHWOL EXTRA oils from eucalyptus, rosemary, lavender and thyme revitalise your feet and increase their performance. GEHWOL EXTRA stimulates the circulation and protects against cold and wet feet.

005567 75ml Tube



1 GEHWOL® Leg Balm

Leg Balm is a pleasantly soothing medicinal herb balm for legs and feet. It contains an astringent effect and relieves irritation. Regular use prevents dry skin and premature ageing of the skin. Dermatologically tested and suitable for diabetics.

- 005569** 125ml
- 005529** 500ml

2 GEHWOL® Mother-of-Pearl Scrub

Caring scrub with Mother-of-Pearl powder for legs and feet. Acts with valuable Mother-of-Pearl powder, fine sugar crystals and massaging wax balls. Nuisance skin scales are removed, the skin is gently massaged and hydrated.

- 09 131 7866** 150ml Jar

3 GEHWOL® Balm

Available in two varieties, one ideal for revitalising dry rough skin and the other for maintaining and improving normal skin. These well-tried antimicrobial substances protect against infections and keep feet hygienically fresh. Dermatologically tested and suitable for diabetics. 75ml tube.

- 016572** Dry Rough Skin
- 005568** Normal Skin

4 GEHWOL® Warming Balm

For cold feet. Moisturising care for dry and normal skin. Extracts of algae, paprika, ginger, essential oils of rosemary and lavender as well as invigorating camphor stimulate the circulation and dispense a pleasant feeling of warmth. Dermatologically tested.

- 09 131 7882** 75ml Tube

5 GEHWOL® Refreshing Balm

Cooling cream for fresh feet. Cares and deodorises. Natural peppermint oil and menthol refresh tired, sore and strained feet and legs. Immediately revitalises, cools and deodorises feet, giving a long-lasting feeling of freshness.

- 009017** 75ml Tube



1 GEHWOL® Caring FOOTDEO

Refreshing foot spray. Deodorises, protects and cares. Contains natural medicinal plant oils, it revitalises and stimulates the circulation. It has a long lasting refreshing and deodorising effect and provides long lasting protection against foot odour. Can be sprayed in any position. Dermatologically tested and suitable for diabetics.

005565 150ml

2 GEHWOL® Liquid

Refreshing, deodorising and skin-caring foot spray. Use once per day to keep fresh feet all day long. Especially effective between the toes and on the heels, immediately alleviates a burning sensation and symptoms of fatigue of the feet. Free from propellants and can be sprayed in any position.

005535 150ml

3 GEHWOL® Bath Salt

Revitalising rosemary bath. Cleanses, refreshes and revitalises the skin. Softly and thoroughly cleanses, stimulates the circulation, revitalises and strengthens the skin. The soothing substances are deeply absorbed into the pores and prevent excessive perspiration and foot odour.

09 131 7890 10x 25g

4 GEHWOL® Foot Bath

Foot bath helps aching, sore and sweaty feet. It revitalises tired feet and eliminates troublesome soreness. Calluses, weals and corns are softened. The skin is cleansed to the pores and remains resistant and smooth. Dermatologically tested.

005541 10x 20g

005571 400g

5 GEHWOL® Cream Footbath

Refreshing and revitalising bath concentrate. With spike lavender and lavender. Regular bathing prevents infections and provides long-term deodorisation.

09 131 7908 150ml

6 GEHWOL® FOOTPOWDER

Special disinfectant powder which prevents against infections, keeps feet dry, smooth and odourless. Can also be used for sprinkling in socks to give all day protection. Only available with German instructions.

005537 100g shaker

7 GEHWOL® Emulsion for foot massage

With essential oils and GEHWOL active ingredients, emulsion for foot massage creates a smooth film on the skin whilst revitalising and stimulating circulation.

005531 125ml

005533 2ltr bottle

005532 500ml refill





1 GEHWOL® FUSSKRAFT RED

For warming cold feet. A warming balm which gives relief for tired, strained and sore feet. Proven antiseptics prevent foot odour, athlete's foot and itching between toes. Skin-friendly concentrated emollients revitalise dry and brittle skin, making it soft and smooth again. Hint: You can intensify the warming effect by using GEHWOL FUSSKRAFT Warming Bath Concentrate beforehand.

Normal Skin		Dry Rough Skin	
005524	75ml	005561	75ml
005510	125ml	09 131 7924	125ml
005511	500ml	005562	500ml

2 GEHWOL® FUSSKRAFT BLUE

A rich emollient cream for burning, tired feet. It contains well-trying antiseptics for the prevention of athlete's foot and itching between the toes. For rough dry skin. Dermatologically tested and suitable for diabetics.

005521	75ml
005507	125ml
005508	500ml

3 GEHWOL® FUSSKRAFT GREEN

A light emollient cream for sweaty feet. Contains the active substance complex Deozinc in a rapidly absorbed, nourishing cream base with shea butter, jojoba oil and aloe vera for long lasting protection against foot odour. Proven disinfecting active substances to prevent athlete's foot, itching and blisters between toes.

005519	75ml
005504	125ml
005505	500ml

4 GEHWOL® FUSSKRAFT MINT

A cooling foot balm which is rapidly absorbed. The revitalising icy freshness of mint makes feet feel fresh and fit. Natural menthol, essential oils from rosemary, mountain pine and lavender refresh and strengthen tired and aching feet instantly.

005552	75ml
005513	125ml
005514	500ml

5 GEHWOL® FUSSKRAFT Warming Bath Concentrate

Foot bath concentrate with precious herbal extracts. Vitalises and thoroughly warms feet and legs. Provides a spontaneous and long-lasting pleasant warming feeling of the feet.

005559	75ml
--------	------

6 GEHWOL® FUSSKRAFT Herbal Bath

Effective against rough and brittle skin, foot perspiration, foot odour and softens calluses. Even persistent calluses, weals and corns are thoroughly softened.

005525	10 x 20g
005558	400g

7 GEHWOL® Leg Vitality

As well as vitalising the skin, it smoothes tired and heavy legs with its ingredients of avocado oil, algae extracts and vitamin E. Hamamelis soothes irritation and prevents wrinkles and problem zones of dry and scaly skin. Dermatologically tested and suitable for diabetics.

005557	125ml
--------	-------

8 GEHWOL® Bamboo Scrub

Gently and thoroughly removes dead skin cells, renews the skin surface and smoothes it. Natural bamboo granulate encourages a gentle massage and activates skin circulation. Vitamin E protects against premature aging.

018981	150ml
--------	-------

1 GEHWOL med Protective Nail and Skin Cream

Contains precious substances, such as wheat germ oil, panthenol and bisabolene, for nail and skin care. Prevents fungal infections, fragile and brittle nails regain their elasticity and beauty. The nails receive a natural silky shine. Dermatologically tested.

005598 15ml

2 GEHWOL med Foot Powder

Provides effective protection against fungal infections, deodorises the feet and keeps them dry. Contains high quality care products tapioca starch, micronised zinc oxide, triclosan and bisabolol for the prevention of foot odours and sweaty feet.

09 131 7916 100g shaker

3 GEHWOL med Salve for cracked skin

A caring ointment for the treatment of heavily callused, brittle, dry and rough skin. With regular use skin will regain its natural elasticity and resistibility. Dermatologically tested and suitable for diabetics.

005596 75ml

005549 125ml

005550 500ml

4 GEHWOL med Lipidro Cream

For optimal care of dry and sensitive skin. The high quality ingredients compensate for a lack of lipids and moisture and naturally balance the protective properties of the skin. Free from fragrances. Dermatologically tested and suitable for diabetics.

010489 75ml

016370 125ml

010490 500ml

5 GEHWOL med Nail protection pen

Long term care for nails, effective protection against fungal infections, makes nails beautiful and supple. The contents are sufficient for approximately 1000 nail treatments.

09 132 0746 3ml pen

6 GEHWOL med Protective Nail and Skin Oil

Effectively protects against fungal infections, the nails and skin regain their elasticity and beauty. The nails receive a natural silky shine. Dermatologically tested.

005597 15ml

7 GEHWOL med Deodorant Foot Cream

Intensive deodorant foot cream with long-lasting protection. Regular use of the mildly moisturising cream gives odourless feet protection against fungi and smoother skin.

005601 75ml

8 GEHWOL med Nail Softener

Quickly and carefully softens cornification and makes cuticles elastic. It alleviates the discomfort of ingrown toenails. The painful pressure of the nail on the nail bed is eliminated.

005599 15ml





1 GEHWOL GERLASAN Axilla Fresh

Long-lasting deodorisation, freshness for day and night. Normalises perspiration and provides care with well-ried skin protecting substances. The scent is clean and discreet.
09 131 7932 150ml

2 GEHWOL Foot + Shoe Deodorant

For daily foot care. Ideal for sports and on the go. Zinc ricinoleate prevents and removes sweat and odour on the feet and in the shoes. The pleasant scent provides confidence. Dermatologically tested.
09 131 7940 150ml

3 GEHWOL Foot Spray

Refreshes, deodorises, protects and nourishes. Fresh feet all day long. GEHWOL Caring Foot Spray refreshes, deodorises and protects effectively against fungal infections. Dermatologically tested.
09 131 7957 150ml

4 GEHWOL med Anti-perspirant

Cream lotion for sweat reduction. GEHWOL med Antiperspirant Cream Lotion leads to drier, odourless feet with daily use. Dermatologically tested.
09 131 7965 150ml

5 GEHWOL FUSSKRAFT Caring Foot Spray

Refreshes whilst removing foot odour. The skin is protected against fungal infections. Natural caring substances soothe the skin and encourage its regeneration. Dermatologically tested.
09 131 7973 150ml

6 GEHWOL med Nail Softener

Quickly and carefully softens cornification. Problems created by ingrown toenails are minimised. The painful pressure of the nail on the nail bed is eliminated.
005599 15ml

7 GEHWOL Nail Compound

Used to smoothen uneven surfaces, strengthen broken nails, fixing artificial nails and for treatment of onychomycosis. Nail polish may be used additionally. For application on skin and nails. Only available with German instructions.
005544 15ml

8 GEHWOL Peeling Paste

Paste for softening and loosening corns and calluses.
09 131 7981 20ml

9 GEHWOL GERLAN Nailcare

For fragile finger and toenails, to support the preparative treatment of nail mycosis. Promotes nail growth.
005572 15ml

10 GEHWOL Corn Tincture

Extra strong, highly concentrated preparation with great depth effect. For removing corns and calluses.
09 131 7999 15ml

11 GEHWOL Fluid

An essential aid while working with instruments on ingrown toenails, calluses, corns and in the perionychium.
09 131 8005 15ml

Massage Therapy

- 364 - 366 G5® Massagers
- 367 Thumper Massagers
- 368 Massage Chairs
- 369 - 370 Massage Tools
- 371 - 378 Massage oils, creams & gels





CE0459
FOR MEDICAL
USE

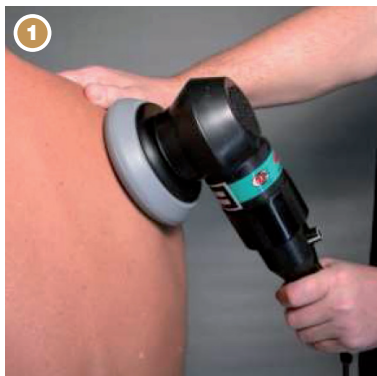

CE0459
FOR MEDICAL
USE



1 G5® Vibracare®

G5® Vibracare® Professional Percussor/Massage system. The G5® Vibracare is a uniquely designed portable massage percussor which makes it ideal for the respiratory therapists in hospitals and at home. It is also used in nursing homes to help prevent bed sores and to help relieve constipation.

- In built Directional-Stroking™ system
- Adjustable frequency 0-60 CPS
- NEW Soft Carry Case
- Kit of 3 applicators

What is Directional-Stroking™?

Directional-Stroking® is in-built with the G5® Vibracare and combines both horizontal and vertical forces, which produce:

- An effective and comfortable percussion
- A mobilisation of waste products
- An oscillating massage

Battery Operated Model

The G5® Vibracare is now also available with its own dedicated NiMh battery pack, so no need for a power point until you need to re-charge. This new unit has at least 5 hours running time after each charge. It's ideal for the travelling sports physiotherapists and nurses working in care homes.

- NiMh Long Life rechargeable battery
- Mains charger

Includes standard accessories as shown:



- MAS566** G5® Vibracare Professional
- MAS567** G5® Vibracare Battery Model

2 G5® Variko®

Our most popular portable G5® system. The G5® Variko™ is a light weight (under 14lbs) professional massage system that has been especially designed for the mobile therapist and is often purchased as an additional unit to the floor standing G5 unit. It is used widely by sports clubs and mobile therapists.

- A unique gyratory massage system that: Mobilises deep, soft tissue, creates a smooth comfortable massage
- Continuously variable frequency range 15-50 CPS
- Strong, heavy duty carrying case
- Kit of 4 interchangeable applicators

Includes standard accessories as shown:



VKC



1 G5® Fleximatic

Our most versatile and popular G5® model. The G5® Fleximatic is being used widely in the UK by many Physiotherapists, Osteopaths, Chiropractors and Sports Clubs.

The G5® system provides a unique therapeutic massage and soft tissue mobilisation.

- 24 Volt brushless motor with internal 24 Volt/150W transformer
- Variable frequency control 0-60 CPS
- Rolling caster stand & accessory tray
- Physio kit of 4 applicators (see list below)
- 2 year warranty

Directional-Stroking™

If you use the AP209 Percussion adapter (optional extra) the G5® produces a Directional-Stroking™ action which produces both horizontal and vertical effects.

The main benefits provided by G5® massage and percussion modalities include:

- Powerful deep massage, or percussion, without tiring the therapist
- Shorter treatment time, which allows the therapist to treat more clients
- Combines "hands on" massage and percussion techniques with the benefits of a quiet but powerful assistive modality
- An effective and comfortable percussion
- A deeper mobilisation of waste products

Includes standard accessories as shown:



AP212
Soft massage



AP227
Trigger Point



AP216
Deep massage



AP230
Relaxation Drainage

FLX24-SP Black
FLX24-SP/WHITE White



Massage Therapy





1 Adjustable Percussion Adapter

For respiratory therapy and deep drainage techniques.
AP209FR

2 Fixed Percussion Adaptor

Used for respirator therapy and deep drainage techniques.
09 143 4174

3 Small Sponge Applicator

For effleurage/soft massage. Includes 5 soft covers. (8cm Dia).
AP210

4 Large Sponge Applicator

For effleurage/soft massage. Includes 5 soft covers. (10cm Dia).
AP212

5 Exfoliation Kit

Including backing plate and 10 disposable sponges, comprising of 5 smooth and 5 coarse.
09 143 4190

6 Disposable Sponges

To be used with AP214M.

AP214FC 10 Coarse

09 143 4182 10 Smooth

7 Multi Prong

Gives deep massage, very effective in sports therapy to stimulate circulation.

AP215S

8 Four ball

Firm rubber (deep muscle petrissage).

09 143 4208

9 Half Ball Silicone

Abdominal massage and sole care.

AP217SD

10 Blunt-tipped

Firm rubber. Useful for deep-working of soft tissue.

AP222

11 Two Ball

Firm rubber. Stimulation of the stomach, massage of the dorsal-lombar zone.

AP223

12 Hot and Cold Applicator

Filled with Cyro Gel. This accessory can be stored in a deep freeze or heated in warm water. For relaxation and tired legs.

09 143 4216

13 Small Prong Silicone Applicator

Exfoliation and peeling.

AP225S

14 Seven Suction Cups

In silicone. Decongesting action.

AP226SD

15 Fine Point

Hard rubber cone. Deep massage of the trigger points.

AP227

16 Silicone Large

Firm rubber. Bronchial drainage/sportive massage.

AP229SD

17 Curved Soft Sponge

Including 5 disposable covers. Limb drainage/relaxation.

AP230

18 Soft Disposable Covers

AP234 50 for use with AP210

AP235 50 for use with AP212

AP236 50 for use with AP230



1 Thumper Maxi Pro

The professional Maxi Pro Thumper is ideal for 2 person use (eg. Doctor & Patient). A full-body thumper massage takes around 5 minutes, leaving the patient completely relaxed. It has eight anatomically-designed massaging spheres which pivot up and down a full 6mm, twenty-seven times per second. Its large size allows you to massage both thighs, calves, feet or paraspinal muscles at once. It weighs 3.2kg which provides all the necessary force to provide a sensational massage! There is no pressing and prodding, just place it on the muscle area of choice and relax.

09 118 3367

2 Thumper Mini Pro2

A lot of power in a little package, the Mini Pro2 is a professional strength massager in a personal, self-use size. Using the same patented thumper percussive action, the Mini Pro2 was designed for those hard to reach areas like the shoulders and mid-back. Two anatomically-designed massage spheres pivot up and down a full 6 mm, adjustable from 20 to 40 times per second producing deep penetrating waves to release tension and knots. Weighing only 1.4kg, the Mini Pro2 has three electronically regulated power settings for use on both thick and thin muscles. Use it on low for the rib cage or on children and elderly, where the full size maxi pro thumper may be too overpowering.

09 118 3391

3 Thumper Sport Pro

Thumper Sport is considered to be the ultimate percussion massager for home use. Developed for active individuals who need to relax their muscles after exercise, and for those who don't get enough exercise and need to improve their circulation. Weighing only 1.4kg, Thumper's Sport patented percussive technology transmits energy deep into the muscle tissue. With a variable speed control from 20 to 40Hz that match your muscles' natural healing frequency. It has an ergonomic handle that accommodates all hand sizes and helps you reach all muscle groups. With interchangeable massage heads that let you customise your massage experience.

09 118 3383

4 Thumper Versa Pro

Versa Pro is a whole new way to release muscular tension and invigorate your tired, aching body. Just rest your feet, calves, thighs or lower back against the Versa Pro and let the healing begin. It has 13 different massage settings, a remote control and 7 auto programs. Self-leveling steel suspension automatically adjusts to different body parts for maximum penetration and relief. 184 acu-pressure nodes are powered by direct-drive percussion and adjustable from 16 to 30 pulses per second.

09 118 3375



1



2



3



4

1



2



1 Professional Therapy Chair Physio-Med

The Physio-Med Therapy Chair is both portable and multi-functional. The thorax panel offers comfort, stability and safety. In the prone and supine position both the head and neck are always well supported by the variable head rest. Ideal for use while treating the back and shoulders and also reduces tension in the neck and back muscles.

MA110

2 Saddle Stool

Treatment saddle stool, height and tilt adjustable in blue.

TAB425

3 Physio-Med Universal Performer

The couch top performer is both lightweight and foldable and will adapt to any surface or couch.

MA-120

4 Deluxe Massage Chair

Our top of the range model, offers total flexibility and a wide range of adjustment. Supplied with black upholstery.

CHR400

3



4



1 Mini Massager

Compact but powerful massager includes three heads for concentrated massage of specific areas. Cap can be left on for massage over larger areas. Battery operated massager vibrates at approximately 5500 cycles per minute. Battery included.

AA9200A



2 Omni Massage Roller

Omni Massage Rollers target problems such as a bad back or stubborn tension knots by rolling away stress and tension. The massagers are just the right size to pinpoint problem areas anywhere on the body and can provide effective relief and deep tissue stimulation simply by rolling the ball in circular motions. They also work well as an aid to traditional massage, helping to improve blood circulation, reduce build up of toxins, relieve tension and alleviate pain. Colour may vary.

AA98265



3 Massage Balls

When massaged on the body these balls help relieve tension and stimulate blood circulation.

	Diameter	Colour
AA90003A	6cm	Orange
AA90003B	7cm	Green
AA90003C	8cm	Yellow
AA90003D	9cm	Red
AA90003E	10cm	Blue



4 Reflexball

These firm textured balls are suitable for massage, hand therapy, reflexology and relaxation exercise.

	Diameter	Colour
AA9807A	8cm	Green
AA9807B	9cm	Blue



5 The Original Jacknobber™ II

This hand held massage tool is used to provide a pleasing and relaxing massage to any part of the body. The knobs at each of its four points can be used to apply deep pressure to muscular trigger points. The smaller knobs provide deeper, more intense pressure. The larger knobs provide broader, gentle pressure. Colour may vary. Latex free.

922286

6 The Original Index Knobber™ II

Ergonomically designed massage tool protects the clinician's hand and forearm against fatigue and over use. Moulded in a highly durable polymer, it allows the user to apply deep, sustained, and precise pressure to trigger points and sore muscles. Colour may vary. Latex free.

922288



7 The Original Backnobber™ II

Deep muscle therapy device constructed of reinforced, polymeric resins. Hook the backnobber over the shoulder or under an arm and use it as a leverage to apply deep pressure to trigger points in the muscles of the neck, shoulders or back. Includes user guide.

922287



1 Acuforce®

The Acuforce® Soft Tissue Therapy Tools are used for trigger point therapy, muscle stripping and cross-fibre friction. What makes these products different? Their weight! All Acuforce products incorporate the weight of each product into its applications. Weight ranges from 11oz for the Massage Star to 7lbs for the Acuforce 7.0! Whether treating an athlete who has completed a tough workout or a person who suffers from sciatica, Acuforce® Soft Tissue Therapy Tools are an ideal way to give patients the deep tissue therapy they need.

- 09 132 9200 **A** Acuforce 2.5
- 09 132 9218 **B** Acuforce 3.0
- 09 132 9226 **C** Acuforce 7.0
- 09 132 9234 **D** Acuforce Massage Star
- 09 132 9242 **E** Acuforce Massage Star XL

2 Roller Massager with Trigger Point Release Grips

The Roller Massager stretches muscles and tendons, breaks down soft tissue adhesion, and soothes tight fascia while increasing blood flow and circulation to the soft tissues. Deep tissue stimulation and massage maximises muscle performance and flexibility. 56cm Long.

09 132 9192

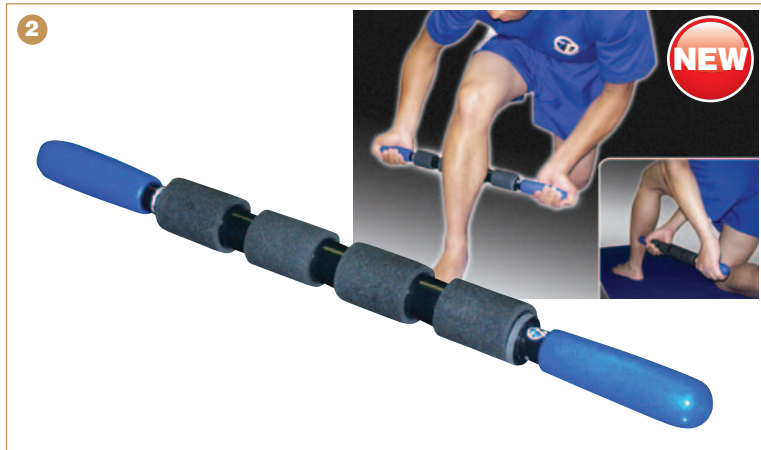

3 The Original Orbit Massager®

The Original Orbit Massager® has a smooth comfortable shape that allows you to give stress releasing, relaxing massage to the back, neck and shoulders and to muscles throughout the body. You can use the Orbit Massager on yourself or on someone you care about. The innovative, gliding action of its freely rotational ball kneads the muscles in the same way the professional massage therapist works to loosen and relax soft tissues and to encourage circulation.

- ORB001EG Emerald Green
- ORB001AP Amethyst Purple
- ORB001RR Ruby Red



4 The Original Palmassager™

The Original Palmassager™ is one of the most efficient massage therapy aids ever made. Hold it firmly in the palm of the hand and use one, two or three of its smooth, round knobs to massage tense, tired or some muscles of the neck, back, shoulders, arms or legs. Ergonomically placed finger holds at the base of each leg provide for optimum comfort and control.

- PALM-SB Sapphire Blue
- PALM-EG Emerald Green
- PALM-AP Amethyst Purple
- PALM-RR Ruby Red
- PALM-GB Glacier Blue



5 Bodybone®

An outstanding anatomically aligned tool, the Bodybone can be used methodically in any therapy and training to loosen up tensions and blockades in the entire spinal area.

09 142 3227





1 Baselin Massage Milk

Non-greasy and specially developed for oily skin. Very suitable for cross fibre tissue work & manipulation.

000182 **A** 500ml

000158 **B** 5ltr

2 Chemodol Massage Oil

Suitable for all skin types. Chemodol looks like a lotion but has a high oil content. Will not stain, water washable. Good skin contact and excellent for general massage.

004576 **A** 500ml

004577 **B** 5 Litre

3 Chemotherm Heat Rub

Contains menthol and eucalyptus oil to provide a mild warming effect. Suitable as a pre-sport rub and non-irritant to patient and massage therapist.

004578 **A** 500ml

004579 **B** 5 Litre

4 Chemovine Hypoallergenic

Chemovine hypoallergenic oil is a water washable clear oil, ideal for use on hairy skin. Will also help prevent hair follicle infection. Pure oil easily absorbed by the skin making it supple. Ideal for skin with heavy hair growth.

004580 **A** 500ml

004581 **B** 5 Litre

5 Chemoderm Massage Oil

Suitable for dry, problem skin. Chemoderm contains camomile oil which helps prevent skin irritation. Also contains Vitamin E, which will help reduce redness in scar tissue.

004582 **A** 500ml

000141 **B** 5 Litre

6 Chemolan Ultrasound Gel Not Illustrated

World Standard for Medical Ultrasound Transmission, it is used for diagnostic and therapeutic medical ultrasound. Recommended for all procedures where a viscous gel is required, including Ultrasonic diagnosis, Ultrasonic therapy, ECG, EEG, EMG and Defibrillation. Neutral contact gel for ultrasound and echotherapy. Has excellent conductive properties, is odourless and has a highly suitable viscosity.

015702 5 Litre

7 Pumps

Pump for 500ml

015701 **A** For 500ml Bottle

Pump for 5ltr

015807 **B** For 5 Litre Bottle



A

B



A

B



A

B



A

B



A

B



A

B

1



1 Massage Oil Vita Silk

- Jojoba oil, vitamin A and E for silky smooth skin
- Gentle fragrance for feel good factor

MAS320	200ml
MAS325	1 Litre
MAS330	5 Litres

2 Massage Oil Neutral

Without any perfumed oils. A special oil-rich lotion with excellent lubricant properties specially developed for extended massages such as sports massages. Particularly suitable for hairy skin. Can be applied sparingly and so is economical in use.

MAS300	200ml
MAS305	1 Litre
MAS310	5 Litres
MAS315	10 Litres

3 Arnica Massage Oil

Arnica Massage Oil contains arnica extract for relaxing muscles and joints as well as high quality plant oils for skin function care.

MAS340	125ml
MAS345	1 Litre

4 Arnica Sport Gel

Alcohol based embrocation, renowned for its healing properties, apply sparingly prior to use of massage oils and lotions.

MAS375	200ml
---------------	-------

2



3



4



1 Massage Lotion pH 5.5

- Protect your hands with the skin friendly aloe vera, panthenol and allantoin
- This top quality massage lotion has excellent lubricating qualities but without the greasy feeling of massage oils
- Dermatological tested

MAS350 200ml

MAS355 1 Litre

MAS365 5 Litres

2 Massage Lotion Top

- An oil with a light consistency for an enhanced massage experience
- Active ingredients aloe vera, allantoin, vitamin E and camomile

MAS380 200ml

MAS385 1 Litre

MAS395 5 Litres

3 Massage Lotion Relax

- Especially suitable for a relaxation massage
- With high content of jojoba oil, vitamin B5 and aloe vera
- The fragrance is based exclusively on essential natural oils
- This range offers an additional soothing, calming and relaxing effect

MAS400 200ml

MAS405 1 Litre

MAS410 5 Litres

4 Massage Lotion Neutral

An alternative oil without any perfume for especially sensitive skin as a neutral base, won't dry out and goes a long way.

MAS415 200ml

MAS420 1 Litre

MAS425 5 Litres





FIRST CLASS
PRODUCTS FOR
PROFESSIONALS



REHABILITATION

1 Naqi Inflam Gel

- Reduces inflammation and pain
- Keeps joints supple

Can be used with a neutral Naqi Massage Lotion, with ultrasound & electrotherapy or with a compress.

09 131 9672 50ml
018355 500ml

2 Naqi Lymph Gel

- Stimulates venous circulation
- Prevents water retention
- Lightens heavy legs

Can be used with a neutral Naqi Massage Lotion, with ultrasound & electrotherapy or with a compress.

09 131 9680 50ml
018354 500ml

3 Naqi Cool Gel

- Very cold gel
- Reduces inflammation and pain

Can be used with a neutral Naqi Massage Lotion, with ultrasound & electrotherapy or with a compress.

09 131 9698 50ml
018461 500ml

4 Naqi Plus Gel

- Stimulates circulation
- Reduces stiff muscles

Can be used with a neutral Naqi Massage Lotion, with ultrasound & electrotherapy or with a compress.

09 131 9706 50ml
018601 500ml

5 Naqi Arnica Gel

- Contusion gel for sprains, injuries and bruises
- Relieves rheumatic pain
- Recommended for functional rehabilitation

Can be used with a neutral Naqi Massage Lotion, with ultrasound & electrotherapy or with a compress.

09 131 9714 100ml

WARMING UP & PROTECTION AGAINST COLD

6 Naqi Arnica Gel

Protective against cold

Protective and water-resistant lipogels that stimulate the circulation and protect against cold.

Naqi Warming Up Competition 1:

- Gentle feeling of heat, specially designed for sensitive skins
- Inclement weather conditions

09 131 9722 100ml

09 131 9730 500ml

Naqi Warming Up Competition 2:

- Pleasant feeling of warmth, makes the skin slightly red
- Inclement weather conditions

09 131 9748 100ml

09 131 9755 500ml

Naqi Warming Up Competition 3:

- Intense feeling of heat, lasting effect
- For extremely bad weather conditions

09 131 9763 100ml

09 131 9771 500ml

Massage gently into legs, arms, back and neck in cold weather ten minutes before exercise and definitely after a warm up massage. If necessary repeat. Avoid contact with the face and mucous membranes.



FIRST CLASS PRODUCTS FOR PROFESSIONALS

Massage Therapy

1 Naqi Massage Lotion

The Golden Standard for Massage Lotions.

Paraben-free and without formaldehyde releasers for an even softer feel for both therapist and patient. Especially designed for longer (sports) massages. Naqi Massage Lotion has excellent lubricating properties, is economical in use, and now even more skin friendly. The new Naqi Massage Lotion regular, no longer contains parabens, nor formaldehyde releasers which enhances the natural harmony of the skin and its environment. It provides intensive hydration which strengthens and softens the skin.

- 011147 500ml
- 010878 5ltr

2 Naqi Massage Lotion Ultra

The Massage Lotion for longer (sports) massages.

Completely preservative-free. With antibacterial emollients for an extra soft feel. Ideal for use in therapy. Naqi's bestselling massage lotion will be even more skin friendly without preservatives, but will retain all its previous assets such as excellent lubricating properties, economical usage and leaves the patient's skin dry after treatment.

- 011146 500ml
- 010880 5ltr

3 Naqi Massage Lotion Light

The Massage Lotion for Short Massages.

Massage lotion with a pleasant texture, ideal for short massages. This lotion provides lasting hydration and protection and restores the natural skin balance. After use the skin feels soft but never oily.

- 011148 500ml
- 010879 5ltr

4 Naqi Massage Lotion Ultra Plus

The Warming Massage Lotion.

Naqi Massage Lotion Ultra Plus provides a warming effect and works easily on the skin. Ideal for physiotherapy treatments. This lotion may cause redness to the skin.

- 010883 500ml
- 09 142 2674 5ltr

5 Naqi Massage Lotion Relax

The Relaxing Massage Lotion.

Completely preservative-free. Natural emulsifiers and essential oils for a relaxing effect. Stimulates the blood circulation. Extra soft feel for both therapist and patients. A brand new hypoallergenic and natural massage lotion for relaxing massages. It contains essential oils such as lavender, bergamot and laurel to ease aching muscles, stimulates the blood circulation and provide a soothing effect for the patient. With its excellent spreadability and soft feel this new lotion will be an absolute must among therapists!

- 09 132 0175 500ml



SKIN IN BALANCE



BIOFREEZE

Freeze your pain with Biofreeze

Biofreeze is the Number 1 recommended topical pain reliever by hands-on healthcare professionals. Biofreeze products help manage discomfort by offering a variety of benefits that assist in therapy, pain relief, exercise, training and overall comfort.

1 BIOFREEZE Gel

- COL630 118ml (4oz)
- COL635 473ml (16oz)
- COL634 946ml (32oz)

2 BIOFREEZE Spray

- COL694 118ml (4oz)
- COL695 473ml (16oz)

3 BIOFREEZE Roll-On

- COL636 89ml (4oz)

4 BIOFREEZE Gel Sachets

Not Illustrated

- COL637 100 x 5ml

5 BIOFREEZE Point Of Sale Display

Not Illustrated

- COL641

6 Painwave™ X4000

Pulsed magnetic wave therapy system featuring clinically proven technology to give lasting pain relief. The Painwave™ X4000 is a revolutionary new pain management device, which is a totally natural alternative to prescription medication. Unlike TENS and micro electric current therapy, Painwave™ does not block pain via pain gateways, instead it reduces and removes the pain and promotes healing at cellular level. Painwave™ treats the cause rather than the symptoms. Painwave™ is a portable hand held device that works by delivering pulsed electromagnetic field therapy (PEMF).

017712

7 Painwave™ Muscle & Joint Balm

A non-greasy, easily absorbed soothing balm for muscles and joints. This formulation includes added Menthol, which allows it to be safely and easily administered directly onto the skin with no greasy residue.

Painwave™ Muscle and Joint Balm helps to soothe aches and pains, whether as a rub for pulled muscles or to ease painful, still joints.

018466 50ml

8 Painwave™ Muscle & Joint Gel

A soothing water-based massage gel for the relief of muscular aches and pains and particularly popular with sports people prior to exercise.

It is clean and simple to use, with only small amounts required to massage gently into the affected area.

018467 100ml

9 Painwave™ Instant Moisturising Derma Spray

Painwave™ Instant Moisturising Derma Spray revitalises and re-hydrates the skin leaving it feeling soft and supple.

018468 150ml



1 Vulkan Pre-Sport Massage

Black Pepper, Rosemary and Grapefruit are blended to provide a stimulating, refreshing massage prior to sport. Designed to promote muscle circulation and help reduce the incidence of injuries.

0014901 500ml

2 Vulkan Post-Sport Massage

A combination of Juniper, Basil and Lemongrass will provide the soothing touch for muscular aches and pains and will also help disperse lactic acid.

0014902 500ml

3 Vulkan Therapeutic Oil

The excellent relaxant properties of this Lavender, Sweet Marjoram and camomile based oil make it the oil of choice to assist the therapist when performing massage.

0014903 500ml



4 Ibuleve Gel

Colourless fragrance-free gel containing Ibuprofen 5% w/w. For the relief of backache, rheumatic and muscular pain, sprains and strains. Reduces swelling and inflammation. Also for pain relief in common arthritic conditions.

002618 30g

004094 50g

5 Ibuleve Spray

Convenient spray reduces pain, swelling and inflammation. Ibuleve Spray is a clear, fragrance-free spray containing ibuprofen, a proven anti-inflammatory painkiller. The spray is specially formulated to allow rapid absorption of ibuprofen through the skin for effective relief at the point of pain.

004095 35ml



6 Mueller Massage Lotion

Softens & soothes as it disappears into the skin. 5 litre comes with pump.

010833 474ml

010834 5 Litre

7 Mueller Sports Balm

Greaseless analgesic lotion for warming pain relief. Great for warming muscles before play and afterwards to help relieve soreness.

010856 474ml



8 Fisiocrem

Fisiocrem is a fast working anti-inflammatory cream suitable for use during the treatment of strained muscles, bruising, sprains, tendonitis, dislocations and other injuries. It aids the local circulation and may also offer some relief for rheumatism, arthritis, or venous congestion. Fisiocrem is a completely natural product that can be used in conjunction with pharmaceutical medicine and other physiotherapeutic treatments. It is recommended for use in all types of musculo/skeletal treatment and is suitable for use during all stages of rehabilitation therapy of muscles and joints. It quickly soothes the pain and inflammation of common injuries, bruises, sprains and strains. Avoid open wounds.

09 118 9851 60ml

09 118 9802 250ml

9 Vulkan Sports Balm

More economical than traditional heat rubs in tubes, this pre-sport heat balm comes in 2 sizes.

002930 560ml



1



1 Weleda Massage Balm

Weleda Massage Balm with Arnica. For muscular and rheumatic pain.

- 000386 50ml
- 000387 100ml
- 000388 500ml

Weleda Massage Balm Dispenser

Dispenser comes free of charge.

- 09 125 7948 Dispenser for 100ml
- 09 127 8712 Dispenser for 500ml

2



3



2 Rhus Tox Ointment

For symptomatic relief of rheumatism, recommended where there is muscular stiffness or muscle strain.

- 000381 100g

3 Ruta Ointment

For symptomatic relief of sprains. Recommended where tendons and ligaments are affected, where pain is due to excessive physical activity.

- 000382 100g

4 Profelan Arnica

Helps with the effects of sports, injuries and accidents such as bruises, sprains, pulled ligaments, sore muscles, contusions and bumps.

- 018426 100g

5 Arnica Lotion

A traditional herbal remedy for symptomatic relief of sprains, muscular pain or stiffness, to reduce bruising and swelling from minor bumps. Helpful as a wet compress. A few drops in a warm bath can help relieve aching muscles.

- 000383 50ml

6 Arnica Ointment

A traditional herbal remedy made with organic arnica for the symptomatic relief of bruising, muscular stiffness and to help reduce swelling after minor bumps or sprains.

- 000377 25g

7 Almond Carrier Oil

- 001616 500ml

8 Lavender Essential Oil

- 001641 10ml

9 Tea Tree Oil

- 001647 10ml

10 Bio Oil

- 018452 200ml

4



5



6



7



8



9



10



Electrotherapy

482 - 495	Chattanooga	506 - 507	Compex 3
482 - 483, 490, 493	Combination Therapy	508 - 509	Thera-Son Ultrasound
484 - 485, 492	Stim	510	Ultrasound
486	Vacuum Electrode Module	511 - 513	Biofeedback
487	EMG, Battery & Channel 3/4 Stim	512	Stim
488 - 489	Laser	514 - 518	Interferential & Muscle Stim
491	Ultrasound	519	Neurostimulation
494 - 495	Chattanooga Accessories	520	Laser
496 - 505	Metron	521 - 523	Shortwave
496 - 497, 499	Ultrasound	524 - 525	Shockwave
498, 500, 505	Combination	526 - 529	TENS
501, 503	Stim	530 - 532	TENS Garments
502, 504	Vacuum	533 - 537	Electrodes
502	Laser	538 - 542	Accessories
504 - 505	Interferential	541	Gel
		542	Electroacupuncture
		543 - 546	Compression Therapy





Combination electrotherapy and ultrasound

The unique modularity found in the Intellect Advanced Therapy System allows for easy customisation.

Intellect® Advanced Combo

Features

- More than 25 clinical waveforms
- 2 independent electrotherapy channels
- High resolution colour display of all screens
- Over 200 Clinical Protocols
- Over 100 User-defined protocol slots
- Over 10 Quick-Link Indications for quick parameter retrieval
- Impressive clinical library which includes full colour graphic anatomical and pathological libraries on vibrant LCD screen
- Constant current/constant voltage modes
- Surface EMG and EMG plus stim (optional)
- Documentation of treatment outcomes with Patient Data Cards
- Sequencing to direct a designated therapeutic course without having to modify the unit
- 1 & 3 MHz ultrasound frequencies
- Pulsed & Continuous Modes (10%, 20%, 50% & 100%)
- Variable Duty Cycles (16Hz, 48Hz & 100Hz)
- Newly redesigned ultrasound heads for improved ERA during treatment
- BNR <6:1

- Ergonomically designed sound heads in 1cm², 2cm², 5cm² & 10cm² sizes
- Sound head coupling features with both visual & audio feedback
- Head warming option on sound heads for patient comfort
- 3 year warranty

All units include as standard: Patient data card, 5cm² applicator, Nylatex wrap, 6 x 8cm carbon electrodes and sponges (x4), Dura-Stick Plus 5cm round electrodes (x4), ultrasound gel and user manual. The Intellect Advanced Colour Combo + EMG also includes sEMG and sEMG+ electrical stimulation module and intravaginal probe. Additional components that can be added to the Combo base now or later with a simple upgrade include: EMG, 2 additional channels of stimulation, laser therapy, vacuum and battery.

i INFORMATION
For more information on the optional modules, please see pages 486 to 487.



SHOWN WITH THERAPY SYSTEM CART

- CHA2762CC** Intellect Advanced Colour Combo + EMG
- CHA2752CC** Intellect Advanced Colour Combo (non EMG)
- CHA2772MC** Intellect Advanced Monochromatic Combo

Accessories

- CHA2771** sEMG and sEMG+ Electrical Stimulation Module
- CHA2767** Battery Module
- CHA2766** Laser Therapy Module
- CHA2770** Channel 3/4 Stimulation Module
- CHA2785** Vacuum Electrode Module
- CHA2774** Vacuum Module with Therapy System Cart
- 09 142 9604** Dura-Stick Plus 5cm Round Electrodes
- CHA27469** Patient Interrupt Switch
- CHA27465** Patient Data Card (x25)
- CHA27333** 1cm² Applicator
- CHA27334** 2cm² Applicator
- CHA27335** 5cm² Applicator
- CHA27336** 10cm² Applicator
- CHA79967** 6 x 8cm Carbon Electrodes (x4)
- CHA79970** 6 x 8cm Sponges (x4)
- CHA27468** Intellect Advanced Carrying Bag
- CHA2775** Therapy System Cart
- 09 115 5647** Intravaginal Probe

Technical Specification	
Mains Power:	100-240VAC, 50-60Hz
Weight:	3.2kg
Dimensions: (L x W x H)	33 x 24 x 29cm
Electrical Safety Class:	Class I, Electrotherapy Type BF, Ultrasound Type B
Safety Tests:	IEC 60601-1, IEC 60601-1-2, IEC 60601-2-5, IEC 60601-2-10

Waveforms and Ultrasound

Interferential <ul style="list-style-type: none"> Four Pole Manual Vector Scan Two Pole (Premodulated) 	TENS <ul style="list-style-type: none"> Asymmetrical Biphasic Symmetrical Biphasic Alternating Rectangular Monophasic Rectangular 	Microcurrent
Russian <ul style="list-style-type: none"> Continuous Cycle Timed 	IONTOPHORESIS	Trabert
Galvanic <ul style="list-style-type: none"> Continuous (Galvanic) Medium Freq. Interrupted 	VMS <ul style="list-style-type: none"> Continuous Cycle timed Burst 	Surged
Monophasic <ul style="list-style-type: none"> Continuous Cycle Timed Rectangular Pulsed Triangular Pulsed Surged 	Diadynamic <ul style="list-style-type: none"> MF • DF • CP • LP • CP • ISO CP-ID • MF+CP MF+CP-ID • DF+LP DF+CP 	Ultrasound <ul style="list-style-type: none"> 1 and 3 MHz Head Contact Control Pulsed Repetition Frequency Electronic Signature
	High Voltage Pulsed Current (HVPC)	S/D CURVE



Two channel electrotherapy

The unique modularity found in the Intelect Advanced Therapy System allows for easy customisation.

Intelect® Advanced Stim

Features

- A complete range of clinical waveforms
- 2 independent electrotherapy channels
- Over 200 Clinical Protocols
- Over 100 User-defined protocol slots
- Over 10 Quick-link Indications
- Clinical library includes anatomical and pathological libraries on vibrant LCD screen
- Store treatment sessions easily on Patient Data Cards equipped with the system
- Sequencing to direct a designated therapeutic course without having to modify unit parameters

- Constant current/constant voltage modes
- On screen pad contact quality indicator
- 3 year warranty

All units include as standard: Patient data card, Nylatex wrap, 6 x 8cm carbon electrodes and sponges (x4), Dura-Stick Plus 5cm round electrodes (x4), ultrasound gel and user manual. The Intelect Advanced Colour Stim + EMG also includes sEMG and sEMG+ electrical stimulation module and intravaginal probe. Additional components that can be added to the Stim base now or later with a simple upgrade include: EMG, 2 additional channels of stimulation, laser therapy, vacuum and battery.



SHOWN WITH THERAPY SYSTEM CART

- 09 142 9737** Intelect Advanced Colour Stim + EMG
- 09 142 9745** Intelect Advanced Colour Stim
- 09 142 9752** Intelect Advanced Monochromatic Stim
- Accessories**
- CHA2771** sEMG and sEMG+Electrical Stimulation Module
- CHA2767** Battery Module
- CHA2766** Laser Therapy Module
- CHA2770** Channel 3/4 Stimulation Module
- CHA2785** Vacuum Electrode Module
- CHA2774** Vacuum Module with Therapy System Cart
- 09 142 9604** Dura-Stick Plus 5cm Round Electrodes
- CHA27469** Patient Interrupt Switch
- CHA27465** Patient Data Card (x25)
- CHA79967** 6 x 8cm Carbon Electrodes (x4)
- CHA79970** 6 x 8cm Sponges (x4)
- CHA27468** Intelect Advanced Carrying Bag
- CHA2775** Therapy System Cart
- 09 115 5647** Intravaginal Probe

Technical Specification	
Mains Power:	100-240 VAC, 50-60Hz
Weight:	3.2kg
Dimensions:(L x W x H)	33 x 24 x 29cm
Electrical Safety Class:	Class 1, Type BF
Safety Tests:	IEC 60601-1, IEC 60601-1-2

Waveforms and Ultrasound

Interferential <ul style="list-style-type: none"> • Four Pole • Manual Vector Scan • Two Pole (Premodulated) 	TENS <ul style="list-style-type: none"> • Asymmetrical Biphasic • Symmetrical Biphasic • Alternating Rectangular • Monophasic Rectangular 	Microcurrent
Russian <ul style="list-style-type: none"> • Continuous • Cycle Timed 	IONTOPHORESIS	Trabert / Ultra Reiz
Galvanic <ul style="list-style-type: none"> • Continuous (Galvanic) • Medium Freq. Interrupted 	VMS <ul style="list-style-type: none"> • Continuous • Cycle timed • Burst 	Surged/Faradic <ul style="list-style-type: none"> • Rectangular • Triangular
Monophasic <ul style="list-style-type: none"> • Continuous • Cycle Timed • Rectangular Pulsed • Triangular Pulsed • Surged 	Diadynamic <ul style="list-style-type: none"> • MF • DF • CP • LP • CP • ISO • CP-ID • MF+CP • MF+CP-ID • DF+LP • DF+CP 	Ultrasound <ul style="list-style-type: none"> • 1 and 3 MHz • Head Contact Control • Pulsed Repetition Frequency • Electronic Signature
	High Voltage Pulsed Current	S/D CURVE



1 Vacuum Electrode Module

- 2 channel module that can support 4 channels with the addition of a second module in the Therapy System Cart
- Quick control knobs make adjustment of cup strength simple
- Unique positioning of vacuum in Therapy cart allows for efficient draining into reservoir below and makes reservoir bin cleaning easily accessible
- Easy connection to any Intellect Advanced Electrotherapy or Combination unit positioned on Therapy System Cart
- Various sizes of Vacuum Electrode Cups available

Comes with standard accessories: 60mm stainless steel vacuum electrodes and sponges (x4), Ch 1/3 vacuum lead hose (black), Ch 2/4 vacuum lead hose (grey).

- CHA2785** Vacuum Electrode Module
- CHA2774** Vacuum Electrode Module with Therapy System Cart

- Accessories**
- CHA56852** 60mm Vacuum Electrodes Stainless Steel (x4)
 - 09 142 9760** 60mm Vacuum Electrodes Aluminium (x4)
 - CHA56806** 60mm Vacuum Sponges (x4)
 - CH27657** 30mm Vacuum Electrodes Stainless Steel (x4)
 - 09 142 9786** 30mm Vacuum Electrodes Aluminium (x4)
 - 09 142 9794** 30mm Vacuum Sponges (x4)
 - 09 142 9802** 90mm Vacuum Electrodes Stainless Steel (x4)
 - 09 142 9810** 90mm Vacuum Electrodes Aluminium (x4)
 - 09 142 9828** 90mm Vacuum Sponges (x4)
 - 09 142 9836** Ch 1/3 Vacuum Lead Hose (Black)
 - 09 142 9844** Ch 2/4 Vacuum Lead Hose (Grey)
 - 09 142 9851** Channel 1 Vacuum Lead Hose (x2) (Black)
 - 09 142 9869** Channel 2 Vacuum Lead Hose (x2) (Grey)

Technical Specification	
Weight:	2kg
Dimensions:(L x W x H)	23 x 13.7 x 24cm
Electrical Safety Class:	Class I, Type BF
Safety Tests:	IEC 60601-1, IEC 60601-1-2

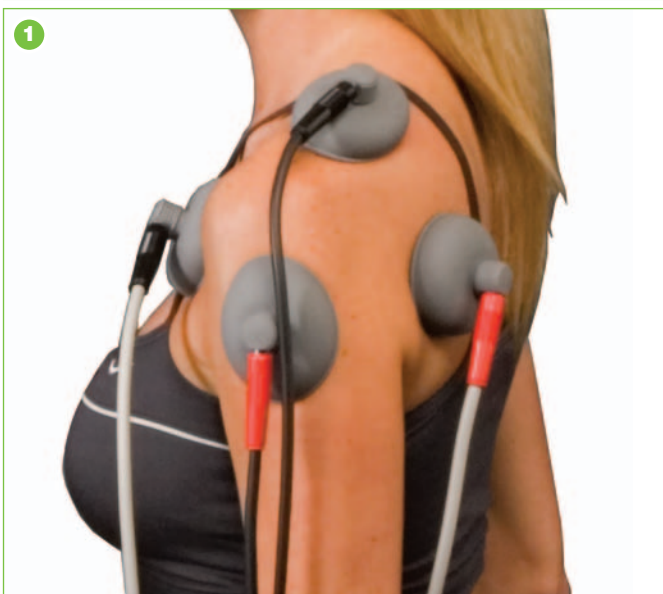

1 sEMG and sEMG Activated Stim

Technical Specification

Weight:	1.5kg
Dimensions:(L x W x H)	9.2 x 8.8 x 3.5cm
Input Impedance:	>1,000,000 ohms
Input Sensitivity:	<1.0µV RMS
Frequency Range:	15Hz-300Hz w/ CMMR of >120dB
Electrical Safety Class:	Class I, Type BF
Safety Tests:	IEC 60601-1, IEC 60601-1-2

CHA2771

2 Battery Module

Nickel Metal Hydride battery self contained in packs of 10 cells

- Battery automatically and continually charges when Intellect Advanced unit is plugged into mains supply
- Lightweight at only 1.3 kg

Technical Specification

Weight:	1.3 kg
Dimensions:	(L x W x H) 30 x 21 x 4cm
Electrical Safety Class:	Class I, Type BF
Safety Tests:	IEC 60601-1, IEC 60601-1-2

CHA2767

3 Channel 3/4 Stimulation Module

- 4 independent channels available on both Intellect Advanced Electrotherapy and Combination devices to upgrade unit from 2 channels
- Includes colour-coded front access panel to hide excessive connections and lead wires

Technical Specification

Main Powers:	120-240 VAC, 50-60Hz
Weight:	5.0kg
Dimensions:	(L x W x H) 30 x 21 x 4cm
Electrical Safety Class:	Class I, Type BF
Safety Tests:	IEC 60601-1, IEC 60601-1-2, IEC 60601-2-10

CHA2770



1



2



3

Laser Module

Low Level Laser Therapy

Features

- Fully functional device with independent control over all parameters
- Display of energy in choice of joules or joules/cm²
- Continuous and pulsed treatment modes with fully variable pulsed frequencies
- Real time feedback of energy delivered
- Full selection of clinical indications specific to laser applicator selected
- Wide variety of LED, Laser Diodes & Cluster Probes available
- User-defined protocol slots on board
- Easy connection to existing Intellect Advanced Electrotherapy or Combination device
- Built in acupuncture point finder

Technical Specification

Weight:	1kg
Dimensions: (L x W x H)	26 x 21 x 4cm
Electrical Safety Class:	Class 1, Type B
Safety Tests:	IEC 60601-1, IEC 60825-1, EN 606061-2-22
	Visible and invisible laser radiation. Avoid direct exposure to beam. Class 3B Laser Product.

Complete with user manual and laser protection glasses (x2)

CHA2766 Laser Therapy Module



Laser Applicators

For use with Laser Module and Intellect® Mobile Laser

Singles

- CHA27799** 670nm LED Diode 10mW
- 09 142 9877** 850nm Laser Diode 40mW
- CHA27840** 850nm Laser Diode 100mW
- 09 142 9885** 850nm Laser Diode 150mW
- CHA27841** 850nm Laser Diode 200mW
- 09 142 9893** 820nm Laser Diode 300mW

9 Diode Cluster

- 09 142 9901** 9 Diode Cluster Applicator, 290mW:
5 x 850nm 50mW Lasers,
4 x 670nm 10mW LED

- CHA27811** 9 Diode Cluster Applicator, 540mW:
5 x 850nm 100mW Lasers,
4 x 670nm 10mW LED

- CHA27812** 9 Diode Cluster Applicator, 1040mW:
5 x 850nm 200mW Lasers,
4 x 670nm 10mW LED

13 Diode Cluster

- 09 142 9919** 13 Diode Cluster Applicator, 265mW:
3 x 850nm 50mW Lasers,
7 x 670nm 10mW LED,
3 x 950nm 15mW LED

- CHA27814** 13 Diode Cluster Applicator, 415mW:
3 x 850nm 100mW Lasers,
7 x 670nm 10mW LED,
3 x 950nm 15mW LED

- 09 142 9927** 13 Diode Cluster Applicator, 715mW:
3 x 850nm 200mW Lasers,
7 x 670nm 10mW LED, 3 x 950nm 15mW LED

19 Diode Cluster

- CHA27815** 19 Diode Cluster Applicator, 325mW:
LED only, 6 x 670nm 10mW LED,
7 x 880nm 25mW LED, 6 x 950nm 15mW LED

33 Diode Cluster

- CHA27809** 33 Diode Cluster Applicator, 565mW:
LED only, 12 x 670nm 10mW LED,
13 x 880nm 25mW LED, 8 x 950nm 15mW LED

- 09 142 9935** 33 Diode Cluster Applicator, 690mW:
5 x 850nm 50mW Lasers,
12 x 670nm 10mW LED,
8 x 880nm 25mW LED, 8 x 950nm 15mW LED

- CHA27807** 33 Diode Cluster Applicator, 940mW:
5 x 850nm 100mW Lasers,
12 x 670nm 10mW LED,
8 x 880nm 25mW LED, 8 x 950nm 15mW LED

- CHA27808** 33 Diode Cluster Applicator, 1440mW:
5 x 850nm 200mW Lasers,
12 x 670nm 10mW LED,
8 x 880nm 25mW LED, 8 x 950nm 15mW LED



Intellect® Mobile Laser

The fully functional Intellect Mobile Laser unit is designed to give independent control over all parameters. This unit has both continuous and pulsed operation settings, along with fully variable pulse frequencies.

Features

- Class 3B Low Level Laser Therapy
- Independent control over all parameters
- Continuous and pulsed operation available
- Fully variable pulsed frequencies
- Real time feedback of energy delivered
- Display of energy in choice of joules or joules/cm
- Helpful menu of Clinical Indications specific to the laser applicator
- 15 user-defined memory slots on board
- Built in acupuncture point finder
- 17 different applicators available, including LED, laser diodes, and clusters
- Innovative design allows for cart, table top, wall or mobile use
- New backlit LCD display for better visibility in low light settings
- Improved pq button for easier navigation
- 3 year warranty

Technical Specification	
Mains Powers:	120-240 VAC, 50-60Hz
Weight:	2.3kg
Dimensions:	L 33 x W 29 x H 16.3cm
Electrical Safety Class:	Class 1, Type BF
Safety Tests:	IEC 60601-1, IEC 60825-1, EN 60601-2-22
	Visible and invisible laser radiation. Avoid direct exposure to beam. Class 3B Laser Product.

Complete with user manual and laser protection glasses (x2)

CHA2779 Intellect Mobile Laser



Intelect® Mobile Combo

Features

- 1 and 3 MHz ultrasound frequencies
- Pulsed and continuous ultrasound therapy operation (10%, 20%, 50% & 100%)
- Variable duty cycle outputs of 16 Hz, 48 Hz, or 100 Hz for ultrasound
- Multiple waveforms on board: (2 Pole IFC, 4 Pole IFC, Galvanic, High Voltage Pulsed Current (HVPC), Microcurrent, Russian, Träbert, Monophasic Triangular, Monophasic Rectangular, Diadynamic, VMS and TENS)
- Clinical Indications on board, providing the most appropriate parameter set for a variety of conditions
- 15 user-defined memory positions
- Lightweight design, along with battery- powered option and custom designed mobile carrying bag, make transport easy
- Innovative design allows for cart, table top, wall or mobile use
- New backlit LCD display for better visibility in low light settings
- Improved pq button for easier navigation
- Newly redesigned ultrasound heads for improved ERA during treatment
- BNR <6:1
- Ergonomically designed sound heads available in a variety of sizes (1 cm², 2 cm², 5 cm², and 10 cm²)
- All sound heads are interchangeable due to Electronic Signature™ residing on all applicators
- Head warming feature and head contact control with visual and auditory feedback on all sound heads
- 3 year warranty

CHA2778 Intelect Mobile Combo

Accessories

- CHA27478** Battery Pack
- CHA2774** Vacuum Module with Therapy System Cart
- CHA79967** 6 x 8cm Carbon Electrodes (x4)
- CHA79970** 6 x 8cm Sponges (x4)
- 09 143 0735** 1cm² Applicator
- 09 143 0743** 2cm² Applicator
- 09 143 0750** 5cm² Applicator
- 09 143 0768** 10cm² Applicator
- CHA27467** Intelect Mobile Carrying Bag
- CHA2775** Therapy System Cart
- 09 143 0776** Cart Adapter

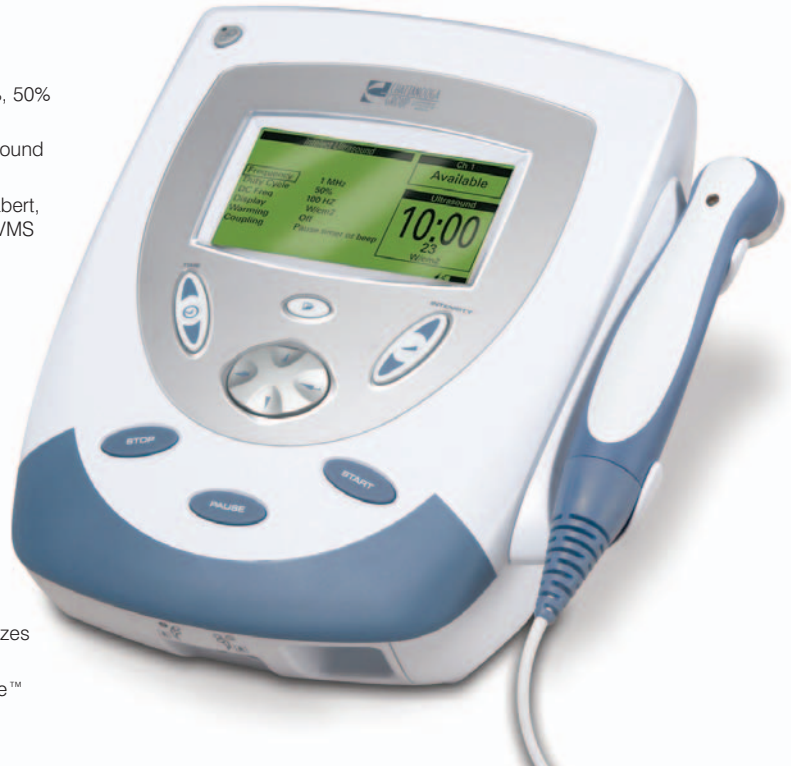

Technical Specification	
Mains Power:	120-240 VAC, 50-60 Hz
Weight:	2.5kg
Dimensions:	L 33 x W 29 x H 25.7cm
Electrical Safety Class:	Class I, Electrotherapy Type BF, Ultrasound Type B
Safety Tests:	IEC 6060-1, IEC 60601-1-2, IEC 60601-2-5, IEC 60601-2-10

Waveforms and Ultrasound			
Interferential <ul style="list-style-type: none"> • Four Pole • Two Pole (Premodulated) 			Monophasic <ul style="list-style-type: none"> • Triangular Pulsed
TENS <ul style="list-style-type: none"> • Asymmetrical Biphasic • Symmetrical Biphasic 	Galvanic	Russian	Monophasic <ul style="list-style-type: none"> • Rectangular Pulsed
IONTOPHORESIS	Träbert	Diadynamic <ul style="list-style-type: none"> • MF • DF • CP • LP • CP • ISO • CP-ID • MF+CP • MF+CP-ID • DF+LP • DF+CP 	

Intelect® Mobile Ultrasound

Intelect®
ADVANCED
THERAPY

Chattanooga's Intelect Mobile Ultrasound is clinically proven to provide the best possible treatment outcomes by utilising a high quality transducer to ensure maximum ultrasound delivery to the treatment area. The output is a clean, culminated beam with the lowest available Beam Non-uniformity Ratio (5:1 maximum). The applicators are designed to provide ultrasound efficiency with no potential for parasitic radiation to the therapist. Each head incorporates head warming and provides a contact control programme with visual and auditory feedback when coupling is present.

Comes complete with 5cm² applicator, ultrasound gel and user manual on CD.

Features

- 1 and 3 MHz frequencies
- Pulsed and continuous therapy operation (10%, 20%, 50% and 100%)
- Variable duty cycle outputs of 16 Hz, 48 Hz, or 100 Hz
- Clinical indications provide the most appropriate application and parameter set for the patient's condition
- 10 user-defined memory positions
- Lightweight design, along with battery-powered option and custom designed mobile carrying bag, make transport easy
- Innovative design allows for cart, table top, wall or mobile use
- New backlit LCD display for better visibility in low light settings
- Improved pq button for easier navigation
- Newly redesigned ultrasound heads for improved ERA during treatment
- BNR <6:1
- Ergonomically designed sound heads in variety of sizes (1 cm², 2 cm², 5 cm², and 10 cm²)
- All sound heads are interchangeable due to Electronic Signature™ residing on all transducers
- Head warming feature and head contact control with visual and auditory feedback on all sound heads
- 3 year warranty

CHA2776 Intelect Mobile Ultrasound

Accessories

09 143 0735 1cm² Applicator

09 143 0743 2cm² Applicator

09 143 0750 5cm² Applicator

09 143 0768 10cm² Applicator

CHA27478 Battery Pack

CHA27467 Intelect Mobile Carrying Bag

CHA2775 Therapy System Cart

09 143 0776 Cart Adapter

Technical Specification	
Mains Power:	120-240 VAC, 50-60Hz
Weight:	2.3kg
Dimensions:	L 33 x W 29 x H 16.3cm
Electrical Safety Class:	Class 1, Type B
Safety Tests:	IEC 60601-1, IEC 60601-1-2, IEC 60601-2-5



Intelect® Mobile Stim

Features

- 2 channels of stimulation output
- Independent intensity and parameter controls for each channel
- Multiple waveforms on board: (2 Pole IFC, 4 Pole IFC, Galvanic, High Voltage Pulsed Current (HVPC), Microcurrent, Russian, Träbert, Monophasic Triangular, Monophasic Rectangular, Diadynamic, VMS and TENS)
- 15 user-defined memory positions
- Lightweight design, along with battery-powered option and custom designed mobile carrying bag, make transport easy
- Innovative design allows for cart, table top, wall or mobile use
- New backlit LCD display for better visibility in low light settings

- Improved pq button for easier navigation
- 3 year warranty

CHA2777

Technical Specification	
Mains Power:	120-240 VAC, 50-60Hz
Weight:	2.3kg
Dimensions:	33 x 29 x 16.3cm
Electrical Safety Class:	Class 1, Type BF
Safety Tests:	IEC 60601-1, IEC 60601-1-2, IEC 60601-2-10



Waveforms					
Interferential <ul style="list-style-type: none"> • Four Pole • Two Pole (Premodulated) 		High Voltage Pulsed Current (HVPC)		Monophasic Triangular	
TENS <ul style="list-style-type: none"> • Asymmetrical Biphasic • Symmetrical Biphasic 		Microcurrent		Monophasic Regular	
IONTOPHORESIS		Galvanic/Direct		Diadynamic	
VMS <ul style="list-style-type: none"> • Continuous • Cycle timed • Burst 		Russian			
		Träbert/Ultra Reiz			

1 Dura-Stick® Premium

Stainless Steel Electrodes

- Superior Conductivity
- Pliable material conforms to irregular body contours yet maintains superior conductivity properties

Blue Gel Electrodes

- Multi-layer adhesive gel optimally bonds to the electrode layer and mesh layer
- Gel is formulated to provide multiple applications to sensitive skin

Dura-Stick® Premium					
	Type	Size	Shape	Pack	
09 142 9554	Blue gel	5cm ²	Square	4	
09 142 9562	Stainless Steel	5cm ²	Square	4	
09 142 9570	Blue gel	4 x 9cm	Rectangle	4	
09 142 9588	Stainless Steel	4 x 9cm	Rectangle	4	
09 142 9596	Stainless Steel	3.2cm dia	Round	4	
09 142 9604	Stainless Steel	5cm dia	Round	4	

2 Dura-Stick® Plus

- Precise control and optimisation of electrical current
- Comfortable and effective stimulation is achieved through the electrode
- Available in cloth or foam backing
- Available with lead wires, proprietary Mi snap connection or standard clip

Dura-Stick® Plus					
	Type	Size	Shape	Connector	Pack
09 142 9612	Cloth	5cm ²	Square	Lead wire	4
09 142 9620	Foam	5cm ²	Square	Lead wire	4
09 142 9638	Cloth	5 x 9cm	Rectangle	Lead wire	4
09 142 9646	Foam	5 x 9cm	Rectangle	Lead wire	4
09 142 9653	Cloth	5cm dia	Round	Lead wire	4
09 142 9661	Cloth	5cm ²	Square	Standard clip	4
09 142 9679	Cloth	5 x 10cm	Rectangle	Standard clip	4
09 142 9687	Cloth	5cm ²	Square	Mi Snap	4
09 142 9695	Cloth	5 x 10cm	Rectangle	Mi Snap	2

3 Dura-Stick®

- Cost effective electrodes without sacrificing comfort and performance
- White cloth backing aids in the conformity of the electrode to the skin

Dura-Stick®			
	Size	Shape	Pack
09 142 9703	5cm ²	Square	2
09 142 9711	5 x 9cm	Rectangle	2
09 142 9729	5cm dia	Round	4

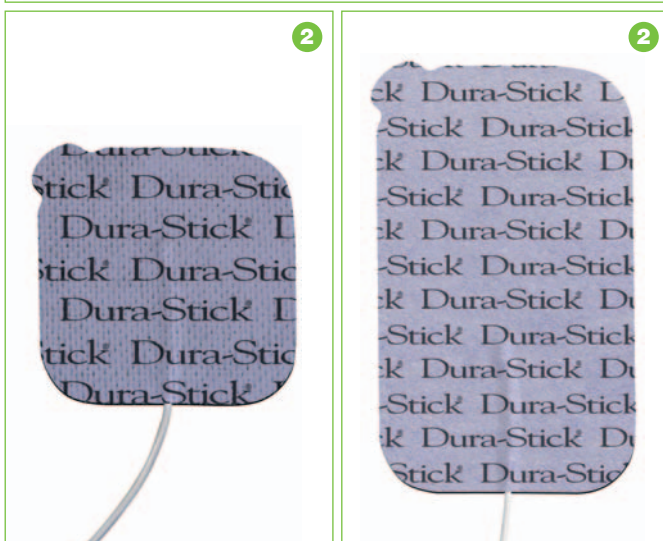

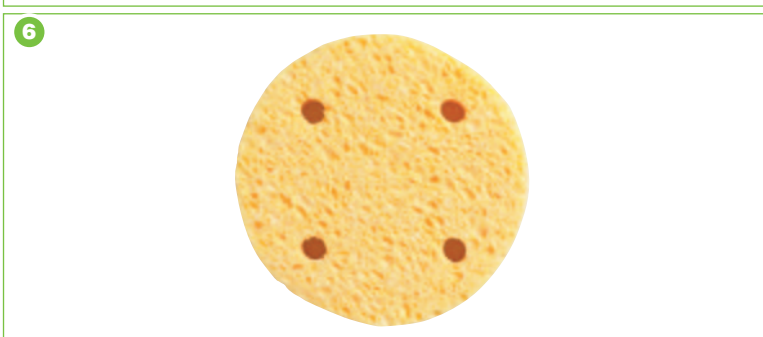

1 Operator Remote

The operator remote confirms comfortably to the operator's hand to allow treatment stop, start or pause at any time during the session. The remote also functions to change amplitude. Each remote is colour-coded to allow designation between channels.

- CH27508** Channel 1 and 2
- CH27079** Channel 3 and 4

2 Therapy Cart System

For use with the Intellect Advanced units, Intellect Mobile units will also fit with the addition of the cart adaptor. Provides useful storage.

CHA2775

3 Cart Adapter

Easily connects any Intellect Mobile unit to a Therapy System cart.

09 143 0776

4 Nylatex Wraps

Nylatex Wraps are made from a stretchable, laminated loop material that is ideal for holding electrodes in place to ensure good contact. Pack of 3

- CHA1202** 6 x 46cm
- CHA1210** 10 x 91cm
- CHA1264** 6 x 61cm
- CHA1212** 10 x 122cm
- CHA1204** 6 x 91cm
- CHA1206** 6 x 122cm
- CHA1208** 10 x 46cm
- CHA1218** 15 x 122cm

5 Vacuum Electrode Cups

Provides secure electrotherapy application to the body. Available in Stainless Steel or Aluminum in the following sizes: 30mm, 60mm & 90mm. Packs of 4.

- CHA27657** 30mm Stainless Steel
- CHA56852** 60mm Stainless Steel
- 09 142 9802** 90mm Stainless Steel
- 09 142 9786** 30mm Aluminium
- 09 142 9760** 60mm Aluminium
- 09 142 9810** 90mm Aluminium

6 Vacuum Sponges

Available in the following sizes: 30mm, 60mm & 90mm. Packs of 4

- 09 142 9794** 30mm
- CHA56806** 60mm
- 09 142 9828** 90mm

7 Stim Lead Wires

Designed with a rip stop feature and colour-coding on the connectors to easily distinguish between channels.

- CHA27312** Channel 1
- CHA27313** Channel 2
- CHA27314** Channel 3
- CHA27315** Channel 4

8 EMG Lead Wires

Designed with a rip stop feature and colour-coding on the connectors to easily distinguish between channels.

- CHA27321** Channel 1
- CHA27322** Channel 2

1 Patient Data Cards

Patient data cards allow patient modality and pain profile information to be recorded from the Intelect Advanced unit and reviewed on the PC, or filed with the patient's treatment records for use in future treatment sessions. Pack of 25

CHA27465

2 Rubber Electrodes

Rubber electrodes are available in the following sizes: 4 x 6cm, 6 x 8cm, and 8 x 12cm.

CHA79966 4 x 6cm

CHA79967 6 x 8cm

CHA79968 8 x 12cm

3 Electrode Sponges

Electrode Sponges are available in the following sizes: 4 x 6cm, 6 x 8cm, and 8 x 12cm.

09 115 5688 4 x 6cm

09 115 5696 6 x 8cm

09 115 5704 8 x 12cm

4 Intelect Advanced Carrying Bag

A ruggedly constructed bag to easily transport the Intelect Advanced unit. All bags are specially designed to hold the unit securely in one side and compartmentalize all necessary accessories in the other.

CHA27468

5 EMG Data Card

EMG data cards record EMG the Advanced unit for download analysis and reporting.

CHA27167

6 Intelect Mobile Carrying Bag

The perfect, ergonomically designed bag to easily allow transport of any Intelect Mobile unit. All bags are specially designed to hold the unit securely in place while providing additional storage for all necessary accessories.

CHA27467

7 Intelect Mobile Battery Pack

A self-contained Nickel Metal Hydride battery that stores conveniently in the bottom of the Intelect Mobile Ultrasound, Stimulation, Combination, or Laser Unit.

CHA27478



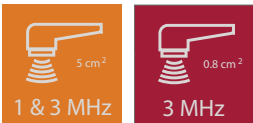

*image shown with optional extra head

1 Accusonic Plus

The Accusonic Plus therapeutic ultrasound offers 1 and 3 MHz from the one detachable applicator. Microprocessor technology has been used to make the Accusonic Plus compact and easy to use. This technology has allowed a number of useful features to be presented in the Accusonic Plus.

Features:

- Up to 10 treatment programmes can be stored in the Accusonic Plus, for quick and easy use
- An LED bar graph is used to display the amount of ultrasound transmission occurring, this helps Practitioners monitor their own, or their staff's technique and correctly deliver the prescribed amount of ultrasound
- The internal service software runs the calibration procedures, minimising the technicians involvement
- Communicates with each transducer to correctly monitor and control frequency and contact sensing
- Contact sensing

Supplied with the following accessories:

- 1 x Multi-Frequency Head - Large - 5cm², 1 & 3MHz
- 1 x 250ml Ultrasound Gel
- 1 x Mains Lead

- ULS510** Accusonic Plus
- ULS111** 3MHz Ultrasound Head - Small 0.8cm²
- 09 142 3508** Carry bag



*image shown with optional extra head

1 Accusonic Advantage

1 & 3MHz Ultrasound

The Metron Accusonic Advantage therapeutic ultrasound now offers 1 and 3MHz from all the available applicators – the standard 5cm² and optional 2.5cm² and 0.8cm². Microprocessor technology has been used to make the Accusonic Advantage compact and easy to use. This technology has allowed a number of useful features to be presented in the Accusonic Advantage.

Features

- Stores 10 treatment protocols for quick and easy patient treatment
- A large 40 Character Backlit LCD displays treatment time, power and protocol names
- An LED bar graph is used to display the amount of ultrasound transmission occurring, and to monitor staff's techniques and to correctly deliver the prescribed amount of ultrasound
- Internal service software runs the calibration procedures, minimising the technician's involvement
- Communicates with each transducer to correctly control frequency and contact sensing

Standard accessories

- 1 x Multi-Frequency Head (Large) - 5cm², 1 & 3MHz
- 1 x 250ml Ultrasound Gel
- 1 x Mains Lead

09 132 8913 Accusonic Advantage Unit

Optional Accessories

- 09 142 3508** Carry Bag
- 09 132 8921** 0.8cm² Applicator 1 & 3MHz
- 09 132 9390** 2.5cm² Applicator 1 & 3MHz

1



*image shown with optional laser probe



1 Accusonic Stim Combo

Combined Ultrasound, Interferential Muscle Stimulation and Advanced Laser

The Accusonic Stim is a combination therapy unit, offering four modes of operation: Bipolar Interferential (Premod), Laser, Ultrasound or combination mode. The stimulator mode offers Bipolar Interferential, TENS, and three different surge modes. The ultrasound mode offers various pulsed and continuous 1MHz outputs. With the addition of the optional laser probe, the Accusonic Stim offers a complete range of electrotherapy modalities. When being used in combination, the 1MHz ultrasound transducer becomes the active electrode.

Standard accessories

- 1 x 1MHz Ultrasound Head 5cm²
- 2 x Rubber Electrodes - 8cm/3.1" x 6cm/2.4" (1 Pair)
- 1 x Patient Lead
- 2 x Electrode Envelope Sponges
- 1 x Elastic Wrap - 7.5cm/3" x 120cm/47"
- 1 x Elastic Wrap - 7.5cm/3" x 60cm/23.6"
- 250ml Bottle Ultrasound Gel
- 1 x Mains Lead
- 1 x Instruction Manual
- 1 x Metron Self Adhesive Electrodes

ELEC06

Optional Accessories

- LAS920** Optional 100mW Laser Diode Probe
- LAS910** SLD Cluster Probe
- 09 142 3508** Carry Bag

2 Ultracheck

Ultrasound Testing Device

The Metron Ultracheck is a simple and cost effective way to ensure your clients are receiving the desired dose of ultrasound therapy both safely and effectively. This simple to use device is designed to test the consistency of output of any ultrasound machine between professional calibrations. Designed by an Australian Physiotherapist in conjunction with a Biophysicist, this simple yet effective device allows the practitioner to test their own ultrasound equipment to ascertain the accuracy of the output. Using the linear scale, immediately after a professional calibration, the therapist is able to measure the output at regular intervals and ensure there are no fluctuations in ultrasound output. The results of these tests are greater confidence in the effectiveness and safety of the ultrasound unit. While the Ultracheck UC170 is not a replacement for professional calibrations or yearly safety checks it will allow the therapist to ensure the accurate operation of their ultrasound. A simple procedure that will take only a few moments to complete and will give the Therapist complete confidence in the effectiveness and safety of their equipment. Each unit comes with a detailed instruction manual and a master test sheet to copy and record the results.

ULS522

2



1 Accusonic

1MHz Ultrasound

The Metron Accusonic therapeutic ultrasound offers 1MHz ultrasound through a detachable applicator. Microprocessor technology has been used to make the Accusonic compact and easy to use. This technology has allowed a number of useful features to be presented in the Accusonic.

Features

- If during the treatment, insufficient contact occurs, then the treatment timer will stop, and the ultrasound output is reduced. Once sufficient contact is detected, then treatment will continue.
- The internal service software runs the calibration procedures, minimising the technician's involvement.
- Communicates with the transducer to correctly monitor and control frequency and contact sensing.

Standard accessories

- 1 x Ultrasound Head - 5cm² - 1MHz
- 1 x 250ml Ultrasound Gel
- 1 x Mains Lead

ULS520 Accusonic

Optional Accessories

09 142 3508 Carry Bag

2 Accusonic LIPUS

Low Intensity Pulsed Ultrasound

A major goal for clinicians when treating patients with a connective tissue injury is to facilitate the return of function, ideally in the shortest time possible. One method of accomplishing this is to accelerate the rate of tissue healing. Accusonic LIPUS represents a modality that has the potential to accomplish this. The Accusonic LIPUS is an ultrasound-based intervention device that has been designed specifically to facilitate the healing of injuries concerned with connective tissues. While ultrasound therapy has been used for many decades to treat connective tissue injuries, its use has not been met with overwhelming success. The LIPUS brings a new direction to ultrasound therapy, one that has evolved from scientific evidence.

Ultrasound Output:

Frequency: 1.1MHz +/- 10%

Output Intensity: 100mW/cm² +/-

Applicator Surface Area: 9.0cm² +/- 4%

Effective Radiating Area: Nominally 5.0cm² +/- 20%

Beam Nonuniformity Ratio: Nominally 5:1 +/- 20%

Pulsed Modulation: Pulse Frequency: 100Hz +/- 3%

Pulse Period: 10 milliseconds +/- 3%

Pulse Width: 2.0 milliseconds +/- 3%

Pulse Duty Cycle: 1:4 (20%) +/- 3%

Supplied with the following accessories:

- 1 x 1MHz 5cm² Ultrasound Transducer
- 1 x 01-08 250ml Ultrasound Gel
- 1 x Elastic Wrap - 7.5cm/3" x 120cm/47"
- 1 x Elastic Wrap - 7.5cm/3" x 60cm/23.6"
- 1 x Instruction Manual
- 1 x Mains Cable

ULS200

Optional Accessories

09 142 3508 Carry Bag



1



2



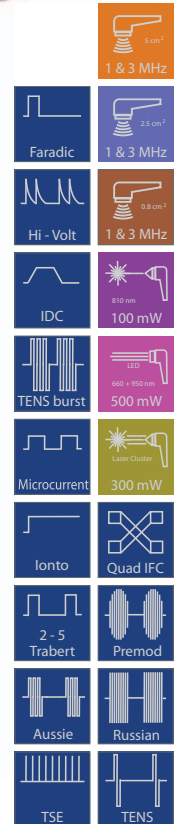

*image shown with optional laser probe

1 Multi-Stim 2 Combo

Channel Electrotherapy, Dual Frequency 1 & 3MHz Ultrasound & Laser

The Multi Stim Combo Unit combines the modalities of Multi Stim, Ultrasound, and Optional Laser Therapy. The Combo Therapy Unit is a revolutionary screen-based design of the Metron Multi-Stim incorporates three rotary controls and a resistive touch screen to set all the treatment variables or to recall stored treatment programs in a simple and straightforward manner. The Ultrasound Therapy unit has a Dual Frequency application, with 1 & 3MHz output. The Metron Multi-Stim can operate as an interferential machine, a high voltage therapy unit, a TENS unit and a Faradic stimulator. There are also several more stim modalities. The optional laser therapy has a 100mW laser diode probe. The Multi-Stim offers a wealth of features but without the complexity.

Ultrasonic Diathermy:

- Dual Frequency 1+3MHz
- 2.4 W/cm² (12 Watts Total)
- 10,20,50 and 100% Duty Cycle

Therapeutic Laser:

- 100 mW laser diode probe (Optional)
- Variable pulse frequency from 10Hz to 5KHz
- 50% and 100% Duty Cycle

Stimulation Current Modes:

- Quadra/Tetrapolar Interferential
- Bipolar/Premodulated Interferential
- Russian/Kotz
- Trabert 2-5
- High Voltage Galvanic
- Faradic
- TENS and TSE
- Iontophoresis/Galvanic
- Interrupted DC
- Microcurrent
- Aussie/Ward

MC100 FDA Approved US Model

ELEC1710 Multi Stim 2 Combo Unit

Optional Accessories

- LAS920** 100mW Laser Diode Probe
- LAS930** Tri Cluster Probe
- 09 132 8921** 0.8cm² Applicator 1 & 3MHz
- 09 132 9390** 2.5cm² Applicator 1 & 3MHz

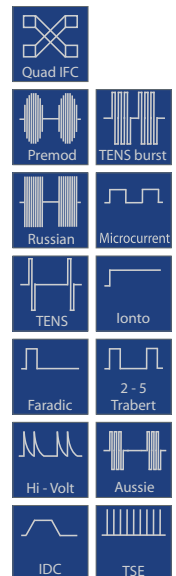

1 Multi-Stim 2

Channel Multi-Mode Modality

The Metron Multi-Stim Therapy Unit is the flagship of the Metron Medical stimulator line. It is a two channel multimode neuromuscular stimulator which offers all the features normally found in separate top of the range electromedical apparatus, in one convenient, simple to operate unit. The revolutionary screen-based design of the Metron Multi-Stim incorporates three rotary controls and a resistive touch screen to set all the treatment variables or to recall stored treatment programs in a simple and straightforward manner. With a large range of modalities available, the Metron Multi-Stim can operate as an interferential machine, a high voltage therapy unit, a TENS unit and a Faradic stimulator. These together with some special extra features such as, Russian, IDC, Galvanic and microcurrents make the Metron Multi-Stim the most advanced unit of its kind.

Stimulation current modes:

- Quadra/Tetrapolar Interferential
- Bipolar/Premodulated Interferential
- Russian/Kotz
- Trabert 2-5
- High Voltage Pulsed Galvanic
- Faradic

- TENS and TSE
- Iontophoresis/Galvanic
- Interrupted DC
- Microcurrent
- Aussie/Ward

Standard accessories

- 4 x Rubber Electrodes - 8cm/3" x 6cm/2.4"
- 4 x Electrode Sponges
- 2 x Elastic Wrap - 7.5cm/3" x 120cm/47"
- 2 x Elastic Wrap - 7.5cm/3" x 60cm/23.6"
- 2 x Patient Leads
- 1 x Metron Self Adhesive Electrodes
- Mains Lead

MS100 FDA approved US model

ELEC1705

Optional Accessories

09 142 3508 Carry Bag

1

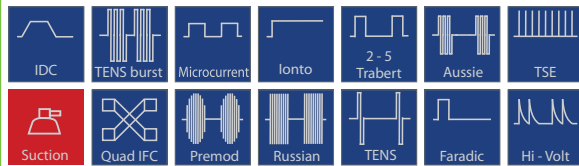

1 Multi-Stim 2 Vac

Combined 2-Channel Multi Modality Stimulator + Vacuum Unit

The Metron Multi-Stim Vac Therapy Unit is a two channel multimode neuromuscular stimulator, combined with a Vacuum Therapy Unit. The revolutionary screen-based design incorporates three rotary controls and a resistive touch screen to set all the treatment variables or to recall stored treatment programs in a simple and straightforward manner. With a large range of modalities available, the Metron Multi-Stim can operate as an interferential machine, a high voltage therapy unit, a TENS unit and a Faradic stimulator. These together with some special extra features such as, Russian, IDC, Galvanic and microcurrents make the Metron Multi-Stim the most advanced unit of its kind. The Vacuum Therapy Unit offers modes of continuous, or a choice of 3 surge settings. The suction intensity is easily adjustable. It offers a wealth of features but without the complexity.

Standard accessories

- 4 x Rubber Electrodes - 8cm/3" x 6cm/2.4"
- 4 x Vacuum Cup - 6.5cm/2.5"
- 4 x Electrode Sponges
- 4 x Vacuum Sponges - 6.5cm/2.5"
- 2 x Elastic Wraps - 7.5cm/2.9" x 120cm/47"
- 2 x Vacuum Lead - 4cm/1.6" Socket (White)
- 2 x Patient Leads
- 2 x Vacuum Lead - 4cm/1.6" Socket (Blue)

Stimulation Current Modes:

- Quadra/Tetrapolar Interferential
- Bipolar/Premodulated

Interferential

- Russian/Kotz
- High Voltage Pulsed Galvanic
- Tens and TSE
- Interrupted DC
- Aussie/Ward
- Trabert 2-5
- Faradic
- Iontophoresis/Galvanic
- Microcurrent

ELEC1730

2



2 Advanced Laser

A New Class 3B Laser offering the latest technology in therapeutic lasers.

Metron Advanced Laser with single 100mW laser probe. The first laser system which allows the therapist to set energy levels (joules) and time from the laser probe.

- Convenient Qprox touch switch for effortless laser activation
- Probe mounted dosage buttons for adjusting treatment energy
- Continuous energy dosage and modulated dosage frequencies from 10Hz to 5KHz

Features

- Mains/battery operation
- Pulsed and continuous output
- Automatic sweep frequency operation
- Weighs only 1.8kgs/3.9lbs
- Conforms with medical device directive (CE)

Standard accessories

- 1 x 100mW laser probe
- 1 x Mains Lead
- Laser Goggles (Two Pairs)
- Instruction Manual

LAS900

Optional Accessories:

LAS910 SLD/LED Cluster with 19 SLD/LED diodes

LAS930 Tri Cluster Probe

09 142 3508 Carry Bag

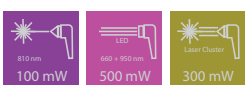

*image shown with optional laser probe

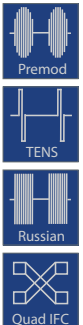

1 Vectorsurge 5

2 Channel Electrotherapy System including 2/4 Pole Interferential and Muscle Stimulation

The Vectorsurge 5 Electrotherapy Unit offers 2 channels for either standard interferential or dual-site bi-polar treatments. This multi-waveform unit features Interferential, Premodulated, TENS and Russian stimulation. A multiple frequency unit, the Vectorsurge 5 offers interferential therapy at 4000Hz plus a 10,000Hz carrier frequency, not found on other leading brands (to maximise comfort during interferential treatments) and a 2500Hz frequency for producing maximum muscle contraction. One control knob selects all the parameters to be easily programmed. "Dial & Set" treatment parameters can be stored and started by simply pressing the start button to begin treatment. CE certified.

Channels:

- Two channels for either standard interferential, or dual-site Bi-Polar treatments

Multi-Wave:

- Interferential, Premodulated, TENS & Russian Stimulation

Multiple Frequencies:

- Offer interferential Therapy at 4000Hz plus a 10,000Hz frequency to maximise comfort during interferential treatments, and a 2500Hz frequency for producing maximum contraction.

Standard accessories

- 2 x Rubber Electrodes - 8cm/3" x 6cm/2.4" (Two Pairs)
- 4 x Electrode Sponges
- 2 x Elastic Wraps - 7.5cm/2.9" x 120cm/47"
- 2 x Elastic Wraps - 7.5cm/3" x 60cm/23.6"
- 2 x Patient Leads
- 1 x Mains Lead
- 1 x Metron Self Adhesive Electrodes

ELEC1415

1



2



1 Vacupulse

Vacuum Therapy Unit

The Vacupulse is the latest edition to the Metron Electrotherapy range. Designed for use with the Vectorsurge 5 and Vectorsonic models, this vacuum unit is a microprocessor controlled system, designed for suction therapy application featuring silent continuous vacuum with 3 independent surge settings.

Standard accessories

- 4 x Vacuum Cup - 6.5cm/2.5"
- 4 x Vacuum Sponge - 6cm/2.4"
- 2 x Vacuum Lead - 4cm/1.6" Socket (White)
- 2 x Vacuum Lead - 4cm/1.6" Socket (Blue)
- 1 x Mains Lead

ELEC1420

Optional Accessories:

- ELA290 Vacuum Cup 95mm Large
- ELA280 Vacuum Sponge 95mm

2 Vectorpulse

Combined 2/4 Pole Interferential Vacuum Unit

The Vectorpulse's interferential module offers 10 user defined programs set up at a push button, manual sweep control, vector rotation, bi-polar and quadropolar operation, and digital displays of all important parameters. The suction module uses an extremely quiet motor. A circuit within the unit monitors the section level continuously, and will automatically maintain the suction level prescribed. This allows suction cups to be placed on one at a time, and if one cup falls off during treatment the remainder will stay attached. Three pulsed modes and a continuous suction mode is provided. Water is trapped in a large internal reservoir and a sensor warns when the reservoir is full, at which time the reservoir can be emptied.

Standard accessories

- 4 x Electrode Sponges
- 2 x Patient Leads
- 2 x Elastic Wraps - 7.5cm/2.9" x 120cm/47"
- 1 x Elastic Wrap - 7.5cm/3" x 60cm/23.6"
- 1 x Mains Lead
- 4 x Vacuum Cup - 6.5cm/2.5"
- 4 x Vacuum Sponges - 6.5cm/2.5"
- 2 x Vacuum Lead - 4cm/1.6" Socket (White)
- 2 x Vacuum Lead - 4cm/1.6" Socket (Blue)
- 2 x Rubber Electrodes - 8cm/3" x 6cm/2.4" (Two Pairs)
- 1 x Metron Self Adhesive Electrodes

ELEC1400

Optional Accessories:

- ELA290 Vacuum Cup 95mm
- ELA280 Vacuum Sponge 95mm



*image shown with optional small head

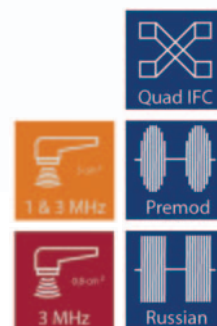

1 Vectorsonic

Combined 2/4 Pole Interferential, 1 & 3MHz Ultrasound

The Vectorsonic is a combination interferential ultrasound unit, offering three modes of operation, interferential, ultrasound or combination mode. The interferential module offers 10 user defined programmes, manual sweep control, optional user defined surge function, automatic vector rotation, bi-polar and quadroplar operation, and digital displays of time and output. The ultrasound module offers various pulsed and continuous 1 & 3MHz outputs. Each mode can be used independently of each other allowing two patient treatments or in combination. When being used in combination the 1MHz ultrasound transducer becomes the active electrode.

Standard accessories

- Multi-frequency head (Large) - 5cm², 1 & 3MHz
- 250ml Bottle Ultrasound Gel
- 2 x Patient Leads
- 4 x Rubber Electrodes - 8cm/3" x 6cm/2.4"
- 4 x Envelope Electrode Sponges
- 1 x Elastic Wrap - 7.5cm/3" x 60cm/23.6"
- 1 x Elastic Wrap - 7.5cm/2.9" x 120cm/47"
- 1 x Mains Lead
- 1 x Metron Self Adhesive Electrodes

ELEC1410

Optional Accessories

- ULS111** Ultrasound Head - Small 3MHz



4 channels and 4 sensors: All you need for top performance!

Integrated electrotherapy and proposed treatments combining for a range of rehabilitation techniques and stimulation therapy. With Compex 3, this approach was taken one step further.

- Manage daily list of patients and treatments
- Access the history of re-education sessions
- Create personalised programs, if necessary. All these features are centralised in the stimulator and everything is easily accessible
- Featuring the Mi Technology, Compex 3 provides all the standard neuro stimulation programs, but also programs for denervation and treatments performed using direct current

Deploy Treatment Methods:

Software, Docking Station and Stimulator

To prepare and manage daily treatment plans and monitor each individual patient, a patient interface establishes a link between the computer and Compex 3 by means of a docking station and a USB connection. The docking station further serves as a storage receptacle and charging station. The patient interface software offers useful, simple and quick functionality for consultants.

Compex 3: A Tool Designed For Treatment

The easy-to-navigate Compex 3 drop-down menus provide all the benefits of modern electrotherapy. Pictograms representing program families provide easy access to applications or specific indications.

Planning

Organise the different stages of patients' electrotherapy treatment:

- By creating a list of patients on the computer
- By assigning personalised treatments
- By transferring the list of patients to the Compex 3
- By updating the list at any time

History / Archiving

Store information in the form of patient files, a great benefit for fast and concise management of electrotherapy work.

Synchronising

Exchange user data and treatment plans between Compex 3 and the computer in seconds.

Programming

Access all electrotherapy programming parameters freely via a user-friendly interface.

Features

- Preset treatment programs for muscular rehabilitation, pain relief, denervated muscles, hyperhidrosis and Iontophoresis
- Create and personalise programs for individual patients
- Mi Technology with four Mi-Sensors included: Mi-Scan, Mi-Action, Mi-Tens, Mi-Range
- Ti-Tens: helps to determine the sensitivity level before starting a Gate control stimulation type session, tailored to each patient
- Denervated treatments: Determine total or partial denervation. For a partial denervation Compex 3 performs an automatic ramp search
- Iontophoresis: Available on one channel. Automatically calculates the advised electrical density.
- Includes motor point pen, this very useful tool together with the dedicated program helps ensure the optimal electrode placement
- Includes User guide, Practical guide and an electrode placement booklet. Access to all the tools plus a video showing all electrode placements in the software
- Rechargeable battery (full charge takes a maximum of 2.5 hours)
- Two year warranty

1 Compex 3

09 143 4604 Compex 3 Kit (incl. electrodes)

Standard Accessories

- 09 143 4448** C3 Bag with CC Logo
- 09 143 4455** Docking Station
- 09 143 4463** Protection Cover
- 09 143 4471** USB Cable
- 09 143 4489** Cable 6P adapter for probe
- 09 143 4505** Battery Pack High Energy
- 09 143 4513** Compex Pro Pack monitor point pen
- 09 143 4521** Bottle of Gel (250g)
- 09 143 4539** Lead Wire with Snap Connector (4 cables/kit)
- 09 143 4547** Lead Wire with Pin Connector (4 cables/kit)
- 09 143 4562** Mi-Sensor Lead Wire (1pc)
- 09 143 4570** Iontophoreses Electrodes (1 set)
- 09 143 4588** Flexible Electrodes (1 set)

Technical Specification	
Power Supply	NiMH, 4.8V, 2000mAh
Weight	300g (+/-15g), incl. battery
Dimensions	L 135 x W 94 x H 33mm
Pulsed Width	30µ seconds – 1000ms
Output Frequency	1-150Hz
Current	0-120mA
PC Synchronisation	USB Connection
Electrical Safety Class	Class II, Type BF
Safety Tests	IEC 60601, IEC 60601-1-2, IEC 60601-1-2-10



2 Dura-Stick® Premium Electrodes

Stainless Steel Electrodes

- Superior Conductivity
- Pliable material conforms to irregular body contours yet maintains superior conductivity properties

Blue Gel Electrodes

- Multi-layer adhesive gel optimally bonds to the electrode layer and mesh layer
- Gel is formulated to provide multiple applications to sensitive skin

	Type	Size	Shape	Pack
09 142 9554	Blue gel	5cm ²	Square	4
09 142 9562	Stainless Steel	5cm ²	Square	4
09 142 9570	Blue gel	4 x 9cm	Rectangle	4
09 142 9588	Stainless Steel	4 x 9cm	Rectangle	4
09 142 9596	Stainless Steel	3.2cm dia	Round	4
09 142 9604	Stainless Steel	5cm dia	Round	4



3 Dura-Stick® Plus Electrodes

- Precise control and optimisation of electrical current
- Comfortable and effective stimulation is achieved through the electrode
- Available in cloth or foam backing
- Available with lead wires, proprietary Mi snap connection or standard clip

	Type	Size	Shape	Connector	Pack
09 142 9612	Cloth	5cm ²	Square	Lead wire	4
09 142 9620	Foam	5cm ²	Square	Lead wire	4
09 142 9638	Cloth	5 x 9cm	Rectangle	Lead wire	4
09 142 9646	Foam	5 x 9cm	Rectangle	Lead wire	4
09 142 9653	Cloth	5cm dia	Round	Lead wire	4
09 142 9661	Cloth	5cm ²	Square	Standard clip	4
09 142 9679	Cloth	5 x 10cm	Rectangle	Standard clip	4
09 142 9687	Cloth	5cm ²	Square	Mi Snap	4
09 142 9695	Cloth	5 x 10cm	Rectangle	Mi Snap	2

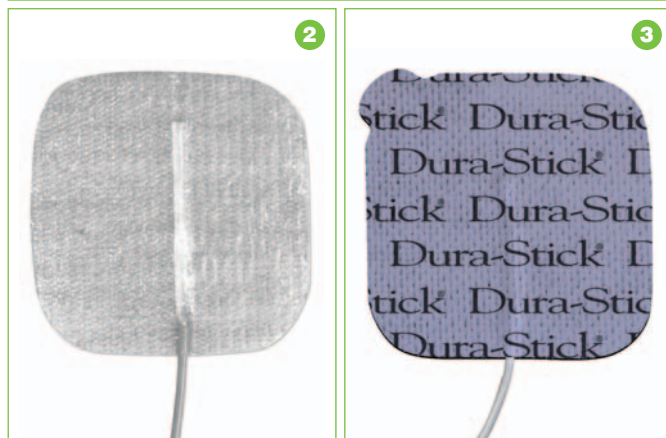

4 Dura-Stick® Electrodes

- Cost effective electrodes without sacrificing comfort and performance
- White cloth backing aids in the conformity of the electrode to the skin

	Size	Shape	Pack
09 142 9703	5cm ²	Square	2
09 142 9711	5 x 9cm	Rectangle	2
09 142 9729	5cm dia	Round	4

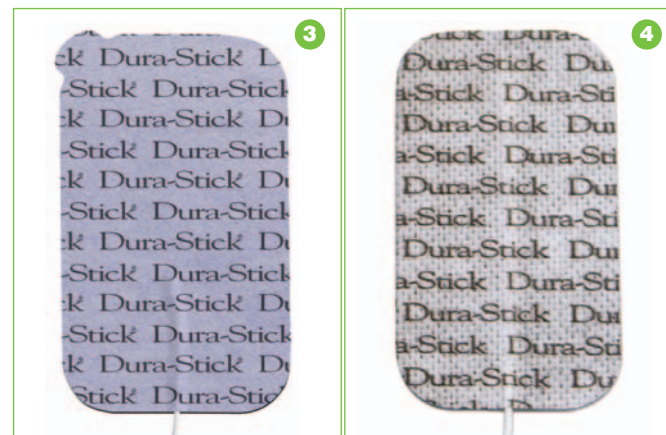



1 Thera-Son 2 - Dual Ultrasound Machine

The Thera-Son 2 has been designed and manufactured to exacting standards here in the UK. It has soft touch panel based controls and a menu navigation system that is displayed on a large backlit LCD screen. Using this the professional can scroll through the Thera-Son's built in treatment protocols or select manual mode and define their own treatment parameters.

Operation:

When standard 5cm² head is in use the unit will automatically operate in ultrasound mode. When the LIPUS head is active the unit will automatically operate in LIPUS mode.

Features:

- Pulsed or Continuous Output
- Pulsed Modes 10%, 20%, 25%, 33%, 50%
- Clear LCD Display
- Duty Cycle 20%
- 3 years warranty
- Manufactured and designed in the UK

Comes complete with mains cable 5cm² dual frequency head operating instructions and a 250ml bottle of ultrasound gel.

ULS450 Thera-Son 2 Ultrasound Unit

Optional extras

ULS460 1cm² Dual frequency Ultrasound Head



1 Thera-Son 2 LIPUS (Low Intensity Pulsed Ultrasound)

The Thera-Son 2 can be used as a LIPUS machine by adding a specific frequency, pulse width, pulse period, and output intensity for a programmed treatment time of 20 minutes per session.

This evidenced based treatment is for the enhanced and faster healing of fractures, non-union fractures, and injuries afflicting connective tissues such as ligaments and tendons.

Operation:

When standard 5cm² head is in use the unit will automatically operate in ultrasound mode. When the LIPUS head is active the unit will automatically operate in LIPUS mode.

Features:

- Uses low profile head (as shown)
- Frequency 1MHz
- Max Tpower: 100Mw/cm²
- Clear LCD Display
- Duty Cycle 20%
- 3 years warranty
- Manufactured and designed in the UK

09 143 4943

2 Thera-Son 2 Trolley

Dimensions Height 75.5cm x Width 30cm x Depth 43cm.

ULS455

3 Thera-Son 2 Carry Bag

A specially designed carry case to hold the Thera-Son 2 unit.

ULS452

1



1 Kinetec Sonomed V Ultrasound Therapy Unit

This lightweight mains powered Dual Frequency Ultrasound unit provides Ultrasound Therapy at 1 and 3MHz, with continuous or a choice of pulsed modes, Digital and built in pre-set protocols.

Features

- 1 and 3MHz treatment head
- Continuous and 3 pulsed settings
- Wide range of commonly used Protocols preset
- 10+ Programmable memory positions

Standard Accessories

- 5cm² ultrasound head
- Ultrasound gel
- Mains lead
- Operating Manual

Technical Specification

Frequency	1 & 3MHz
Treatment heads	1 x Large
Output modes	Continuous and pulsed - 50%, 20% and 10%
Output power	0 - 2W/cm ² (Cont) or 0 - 3W/cm ² (Pulsed)
Timer	0 - 20 minutes
Weight	1.5kg
Dimensions	W 30cm x D 20cm x H 11cm
Power Requirements	100 - 240V 50 - 60Hz
Warranty (Unit)	1 year

09 131 2040 Sonomed Ultrasound Therapy Unit

Optional Accessories

- 220270** Hard Carry Case with Foam Inserts
S0535 Padded Carry Case



1 Clinical EMG

Dual Channel Electromyograph

The Clinical Dual Channel EMG offers easy operation and large, bright bar graph displays which are easily visible from several metres, making this the ideal clinical EMG.

Supplied with the following accessories:

- 1 x Electrode Cable (Blue)
- 1 x Electrode Cable (White)
- 1 x Reference Cable (not shown)
- 1 x Mains Lead (MAI002)
- 1 x Metron Self-Adhesive Electrodes
- 1 x Instruction Manual

Features:

- On/Off power button: Soft touch power - On and Off control
- Dual Bargraphs: Bright 35 Segment LED bargraphs for displaying EMG voltage in 'analog' format, visible several metres away from unit
- Threshold Dials: Rotary dials for quick and intuitive adjustment of threshold levels
- Training Bargraphs: A 35 Segment LED bargraph, shows Work/Rest cycle, and can be used as a 'follow me' training aid
- Select button: selects therapy parameters for data entry
- Set-Adjust Dial: data entry encoder - rotate clockwise for increase, or conversely for decreasing data
- Set-up Indicators: The six set-up indicators are arranged in order for getting started quickly

EMG100

1



1 CombiStimXP® Biofeedback and Muscle Stimulation Unit

CombiStim XP® is the latest device for the treatment of incontinence. Easy to use, flexible and very effective, CombiStim XP® combines the benefits of EMS and EMG in one device. Depending on the patient's specific needs, CombiStim XP® can be used as:

- a pure Biofeedback device
- a pure Muscle Stimulator
- a Combined Biofeedback/Muscle Stimulation device which automatically contracts the patient's pelvic floor muscles on achievement of a preset manual contraction target.

CombiStim XP® comes with 7 programs including an open EMS program where the clinician can choose and set desired stimulation parameters.

Program	Indication
1	ETS (EMG Triggered Stimulation)
2	EMG and EMS alternating
3	EMG Biofeedback
4	EMS - Stress Incontinence
5	EMS - Urge Incontinence
6	EMS - Mixed Incontinence
7	Open EMS Program

Features

- Single Channel
- 3 treatment options, 7 programs
- Clear LED display
- Audio and visual biofeedback

Standard Accessories

- CombiStim unit stand
- 1 x 9v battery (type 6F22/6LR61/PP3)
- 1 x dual lead
- 1 x reference lead
- 1 x internal probe/electrode
- 1 x therapist user manual
- 1 x pack of 4 self-adhesive electrodes

019232

2 CombiStimXP® Software

Software Features

- Patient Database
- EMG Work/Rest Assessment
- EMG template Assessment
- ETS Assessment
- Patient Clinical Report
- Patient's home Compliance Report

022023

1



COMBISTIM PACK

1 Chattanooga Stabilizer

The Stabilizer designed by physical therapists, is a simple device which registers changing pressure in an air filled pressure cell.

The Stabilizer is principally used for exercises that focus on the protection and stabilisation of joints. Research has shown these types of exercises are especially important for the prevention and treatment of low back and neck pain. The Stabilizer is used to monitor and provide feedback on body movement during exercise. 90 days warranty on bag.

Used for:

- Transversus Abdominis with Leg Loading
- Gluteus Maximus
- Deep Neck Flexors
- Lower Trapezius
- Lumbar Stabilisation
- Transverse Abdominis in Supine

STAB01

CHA39959 Replacement Bulb

2 Peritone EMG Biofeedback Unit

The Peritone is a single channel EMG biofeedback device. It can be used in a variety of applications including patella femoral pain, chronic tension headache, asthma, phantom limb pain, incontinence, lower back pain, RSI, pelvic pain, neck and shoulder pain, spinal conditions to name but a few. Its simple design and ease of use make it excellent for both clinic and home treatments.

Features

- Accurate and sensitive - measures activity down to as low as 0.2µv and as high as 2000µv
- LEDs display EMG level clearly and easily
- LCD displays numerical EMG reading and work/rest countdown
- After each session statistics can be reviewed (includes work and rest averages, average onset of muscle contraction and muscle release)
- Lock mode function for recording time in use, statistics and locking the units parameters
- Low cost, high quality and very accurate
- Used with self adhesive electrodes, Periform®+ or Anuform® (not included)
- Optional software available

Standard Accessories

- Patient cable
- Reference cable
- Battery
- User manual
- Stand to hold unit upright during use
- Soft carry case

021848

Additional Accessories

021849 Peritone Software

With the help of optional software Peritone produces and prints comprehensive patient progress reports for all key parameters, such as work/rest averages, onset contractions, muscle release times, peak values and work/rest average deviations

- Microsoft Vista compatible
- New software receives EMG data via the new Fibre Optic to USB adapter

012571 Self Adhesive electrodes 5 x 5cm (pk 4)

021972 Periform®+ Intra vaginal probe

013920 Spare patient cable

Technical Specification	
Range	0.2-2000µv
Sensitivity	0.1µv RMS
Work rest periods	2-99 sec
No. of trials	1-99
Unit dimensions	H 128.5 x W 64 x D 28.3mm
Weight	0.15kg



1



1 Neuro 8 - Two Channel Trophic Stimulator

The Neuro 8 is our latest 2 channel trophic stimulator which replaces the popular Neuro 4. It now has the 8 most common treatments spread across 24 programs as standard. The built in programs and clear liquid crystal display make it simple to use without the need for complex set-up. The unit is supplied with a complete range of accessories as standard including a colour wall chart.

The built in treatment programs are as follows:

- Facial palsy treatments
- Facial sykenius program
- Brachial plexus injuries
- Chronic neurological conditions
- Arthritis program
- Pain relief treatment program
- Sports injury program
- Knee treatment program

Neuro 8 Features

- Clear liquid crystal display
- Extended battery life
- 8 built in treatment conditions
- Free wall chart
- No set up required
- Key lock facility
- 3 years parts and labour warranty

Neuro 8 accessories

- 1 x Neuro 8 unit
- 1 x hard carry case
- 1 x patient lead (2 channel)
- 1 x pack self adhesive electrodes 9cm x 5cm
- 1 x pack self adhesive electrodes 5cm x 5cm
- 1 x fixing tape 9m x 1.25cm
- 2 x facial patient leads complete with stainless steel facial electrodes
- 1 x 60ml tube electrode gel
- 2 x AA batteries

TRO300

2



2 Digi-Stim Multi-Stimulation

The Digi-stim is a new 2 Channel Muscle Stimulation Unit using digital technology to ensure a much more accurate and efficient output. Large LCD screen makes selection of treatment parameters much easier.

The Digi-stim is ideal for:

- The re-education and strengthening of weak muscles
- Reducing muscle spasm
- Increasing range of motion
- Stimulating circulation

Features

- Adjustable frequency range 1-150Hz
- Adjustable pulse width 30 - 260 μ s
- Adjustable ramp up/ramp down times 1 - 6 seconds
- Adjustable interval (relaxation) time 1 - 30 seconds
- Treatment time up to 60 minutes

EMS9000D

1 Bio-Stim - 2/4 Pole Interferential

A new compact Bi-Polar / Quadripolar Interferential Therapy unit which offers the same output as the large clinical models at a fraction of the price. The Bio-Stim is ideal for clinics and private practices where price and space is a premium.

Features:

- 2/4 Pole Interferential
- Adjustable Frequency 1 - 150Hz
- 3 Preset Frequencies 1 - 10Hz, 80 - 150Hz, 1 - 150Hz
- Clear Flip-Up Display with simple operation

Complete with

- 4 x Self Adhesive Electrodes 9cm x 5cm (TPN035)
- 1 x Carry Case, 2 x Patient Leads
- 4 x AA Batteries

ELEC1650 Bio-Stim

Optional Accessories

ELEC1651 AA Rechargeable Batteries

TPN102 Battery Charger



1

2 Ultima Portable 2/4 Pole IFT Unit

A portable interferential unit, capable of operation in 2-pole bipolar or traditional 4-pole modes.

Features

- Easy to use, with full range of adjustments
- 2 channels of 2 pole or 1 channel of 4 pole operation
- 6 preset treatment programs
- Easy to read digital display
- Rechargeable NiMH battery with up to 3 hours operation
- Small and light
- Belt clip

Standard Accessories

The unit is supplied with charger, leads, electrodes, carry case and instructions.

S2350 Ultima Portable IFT Unit

Optional Accessories

S2351 Replacement lead for Ultima

2 YEAR WARRANTY



2

Technical Specification

Range	2 - 160Hz
Carrier wave	4000Hz
Peak-to-peak current	66mA
Waveform	True sinusoidal
Treatment times	15, 30, 45 or 60 minutes with auto shut off
Dimensions	H 11.5 x W 6.6 x D 4.5cm.
Weight	258g

1



1 3 Series EMS

Features

- Large clear digital display
- Easy to use 1 touch operation
- Protective control cover
- Selectable modes: Constant, Sync, Alternate
- 5 year warranty (unit only)

EMS350

2 NeuroTrac Sports

This digital muscle stimulator offers accurate settings, with 15 preset programs and 3 customised programs. It is the ideal unit for quality muscle stimulation.

Features

- 15 preset programs
- 3 user selectable programs
- LCD display

Standard Accessories

- Self adhesive electrodes
- Leads
- Battery
- Manual
- Carry case

S0650

Technical Specification

Output selection	2 Channel
Output modes	Synchronous and alternate
Stim ON time	2 - 60 seconds
Stim OFF time	2 - 60 seconds
On ramp	0.1 - 9.9 seconds
Programs	15 preset, 3 customised
Pulse rate/freq	Variable 2 - 100Hz
Pulse width	50µs to 450µs
Output	0-90mA
Timer	1 - 180 minutes
Battery	1 x 9 volt battery (alkaline)
Dimensions	W 6.3 x D 3 x H 10.5cm
Weight	72g excluding battery
Warranty	2 years - unit only

2



3 NeuroTrac Sports XL

8 Pad Digital Muscle Stimulator

This exciting product offers 8 electrodes operated from 2 separate channels to give greater control over muscle stimulation and the ability to stimulate larger areas.

Features

- Can use up to 8 Electrodes
- Alternating & synchronous stimulation between channels A & B
- 21 preset programs
- 3 user customisable programs
- Lock mode function for measuring home compliance

Standard Accessories

- 4 patient cables, 8 rubber electrodes
- 8 self-adhesives electrodes
- Ultrasound gel
- Battery
- Tape
- Operating manual

S1064

Technical Specification

Output selection	2 Channel
Frequency range	2 - 100Hz
Pulse width	50µs to 330µs
Output current	0 - 90 mA into 500 ohms
Timer	1 - 90 minutes
Waveform mode	Symmetrical, rectangular bi-phasic with zero DC current
Ramp up time	0.1 - 9.9 seconds
Weight	0.18kg
Dimensions	W 6.9 x D 2.9 x H 13.4cm
Power requirements	9 volt PP3 Alkaline or Nickel Metal Hydride rechargeable
Warranty	2 years - unit only

3



1 KNEEHAB® Advanced therapy for Knee injuries

About KNEEHAB™

KNEEHAB is a unique, innovative and clinically proven, garment-based Electrical Muscle Stimulation (EMS) product designed specifically to treat quadriceps atrophy (thigh muscle wastage). Clinical research has shown EMS technology to be an effective treatment for quadriceps atrophy, which is associated with almost all knee injuries and that the use of KNEEHAB can significantly reduce postoperative rehabilitation time.

About EMS

EMS re-educates the muscles by sending gentle electrical pulses through pads placed on the surface of the skin. This electrical stimulation, applied to the motor nerve, causes the muscles to contract, helping to strengthen and build-up the muscle over time.



Channel 1
A+B+D / C

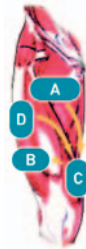

Channel 2
(Delayed)
Stage 1: A / B+C
Stage 2: A / D



About Multipath™

KNEEHAB® incorporates Multipath™, a patented breakthrough stimulation technology which enables KNEEHAB® to deliver highly focused, accurately coordinated and comfortable quadriceps contractions.

How can KNEEHAB help rehabilitate the knee?

KNEEHAB works by re-educating and strengthening the quadriceps muscle through cycles of contraction and relaxation. It can be used to improve joint stability and to treat quadriceps atrophy resulting from a wide range of conditions affecting the knee, including ligament injury, dislocation, fracture, osteoarthritis and stroke. It can be used to help avoid or delay surgery and where surgery is required it can accelerate post-operative rehabilitation.

Key Benefits of using KNEEHAB

Easy to Use

KNEEHAB is a garment-based (thigh wrap) 'all-in-one' product. Once it has been initially set up you just strap it on your thigh and switch the unit on.

Home Therapy Convenience

KNEEHAB is ideal for home use and can be used at a time that suits you. KNEEHAB's design enables error-free and repeatable treatment.

Clinically Proven

Clinical Research has shown EMS and KNEEHAB to be effective in treating thigh muscle weakness and to significantly reduce rehabilitation time.

Comfort

The incorporation of MULTIPATH technology ensures the most comfortable and effective contractions.

Pre-op/Post-op Strengthening

KNEEHAB can be used both pre and post operatively to limit muscle wastage and speed your recovery.

A Faster Recovery Time is Possible...

KNEEHAB can be used to treat quadriceps atrophy (thigh muscle wastage) in the case of a variety of surgeries, injuries and conditions:

- Anterior Cruciate Ligament (ACL) Reconstruction
- Total Knee Replacement
- Post-Fracture
- Arthroscopy
- Post-Stroke
- Patellar Femoral Syndrome
- Patella Dislocation
- Acute and Chronic Arthritis
- General Weakness and Incapacity

021801R Right

021801L Left

Optional Accessories

021802 KNEEHAB® replacement electrodes

021803R KNEEHAB® replacement garment - Right

021803L KNEEHAB® replacement garment - Left

Clinical Proof*

Clinical research has shown EMS technology to be an effective treatment for quadriceps atrophy. Clinical evidence is available.

*Dr. H.H. Pässler (M.A.) & Dr. Sven Fiel, (M.A.), Centre for Knee and Foot Surgery, Sports Traumatology, ATOS Clinic Centre, Heidelberg, Germany: "The effectiveness of Kneehab in strengthening the quadriceps of patients rehabilitating after anterior cruciate ligament reconstruction", Heidelberg 2006.

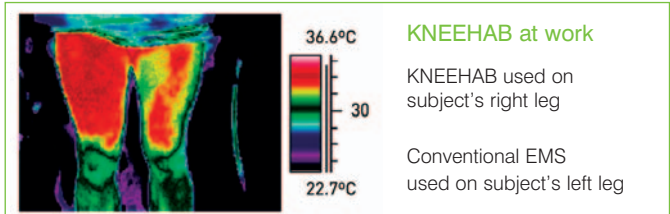



4 PAD H-WAVE



6 PAD H-WAVE

1 H-Wave

H-Wave pain relief for:

- Muscular spasm
- Arthritis
- Acute injuries
- Referred pain
- Frozen shoulder
- Whiplash injuries etc.

H-Wave uses a signal that is natural to the human body. It emulates the H waveform found in nerve signals (Hoffman Reflex) and therefore enables greater and deeper penetration of a low frequency current, whilst using significantly less power than other machines.

H-Wave, being natural to the human body, is accepted more readily and so requires less current to stimulate muscle. Furthermore, because of the natural wave-form of the signal, H-Wave allows you to inject 2 or 3 signals of different frequencies and amplitudes simultaneously, unlike most other electrotherapy modalities.

H-Wave used at 60Hz (equivalent to 120Hz TENS mode) acts as an analgesic/anaesthetic. At 2Hz, muscle stimulation is activated, which is the main form of treatment. Muscle stimulation increases blood flow around the injury site promoting healing and also reduces oedema by encouraging drainage of the lymphatic system.

H-Wave has been proved to be very successful in treating most conditions which have been traditionally treated by electrotherapy. However, it is particularly successful in dealing with difficult conditions such as amputation of diabetics whose poor circulation prevents rapid healing.

- S0661** 6 Pad Human H-Wave
- S0660** 4 Pad Human H-Wave
- S0260** 4 Pad VETWave

There is no difference between the 4 pad Human H-Wave and the 4 pad Vet-Wave. The operation manual for the Vet-Wave is specific to horses, otherwise the electronics and box are exactly the same. The Vet-Wave also comes with a carrying case for field work.

H-Wave combined therapy (2Hz, 16Hz and 60Hz) for:

- Frozen shoulder
- Tennis/golfer's elbow
- Muscle strains
- Back, neck and knee pain
- Achilles tendonitis etc.

Standard Accessories

The Human H-Waves are supplied complete with:

- Human operating manual
- Patient leads
- Charger
- Self-adhesive electrodes
- Electro-mist

The Vet-Wave is supplied complete with:

- Vet operating manual
- Carry bag
- Electrode leads
- Charger
- Self-adhesive electrodes

Technical Specification	
Output selection	4 pad-2 Channel, 6 pad-3 Channel
Frequency range	4 Pad - 2 or 60Hz selectable 6 Pad - 2 to 60Hz variable range
Max current (1K load)	10mA rms (max. amplitude/max. frequency)
Max voltage (1K load)	10V rms (max. amplitude/max. frequency)
Timer	1 - 20 minutes or continuous
Waveform mode	Exponential decaying wave form Bipolar
Weight	4 pad - 2kg / 6 pad - 6kg
Dimensions	4 pad - W 18.5 x D 18.5 x H 6.5cm 6 pad - W 29 x D 28 x H 14cm
Power requirements	Battery operated. Approximately 13 V DC (fully charged) re-chargeable battery
Warranty	1 year - unit only

InterX®

A unique combination of Neurostimulation, Massage, Myofascial Release, Therapeutic Exercise and Trigger Point Therapy.

What is InterX®?

- Non-invasive Interactive Neurostimulation delivered through fixed electrodes of the handheld portable device
- Used by doctors and therapists for the treatment of acute and chronic pain
- Returns patients to active rehabilitation and full function in optimal time

What is InterX® therapy used for?

Evidence based applications for:

- Post surgical rehabilitation
- Sports injury rehabilitation
- Statistical analysis of double blinded, randomised, controlled clinical trials has shown significant results in reduced pain, reduced medication intake, increased range of motion (ROM) and reduced inflammation
- Chronic neuropathic pain
- Chronic musculoskeletal conditions

How does InterX® work?

InterX delivers interactive, high amplitude, high density stimulation to the cutaneous nerves, activating the body's natural pain relieving mechanisms (segmental and descending inhibition). Research suggests that high amplitude stimulation may also activate autonomic responses and point specificity may activate an anti-inflammatory mechanism mediated by peripheral opioids.

How is InterX® therapy applied?

SCAN

Identify optimal treatment points (points of low impedance)

TARGET

Deliver focused, high amplitude stimulation to those points

DYNAMIC

Perform range of motion, flexibility and resistance exercise while treating points of pain

1 InterX® 5002 Kit

- Specifically designed for the management of chronic and acute pain, as well as rehabilitation from injury
- Stainless steel fixed concentric electrodes
- Constant current device
- Graphic display with simple selection navigation and selection
- Preset stimulation patterns
- Effective treatment times from 5 to 30 minutes
- Fully portable, battery operated, weighing only 315g
- Minimal set-up time, no skin preparation and no gel needed
- No calibration required

021765 InterX® 5002

Optional Accessories

- 021767 Classic Electrode
- 021768 Small Circular electrode
- 021769 Comb Electrode
- 021770 Soft Tissue Electrode
- 021771 Dome Electrode Kit
- 021772 4x4 Flexible Array Electrode Kit
- 021773 3x3 Dual Flexible Array Electrode Kit
- 021774 Professional Device Holster
- 021775 Personal Device Pouch
- 021776 Professional Carry Case
- 021777 Utility Bag small

2 InterX® 1000 Kit

For personal treatment & management of pain

021766 InterX® 1000

Technical Specification		
	InterX® 5002	InterX® 1000
Size	220 x 60 x 45mm	215 x 52 x 43mm
Weight	315g	185g
Power source	4AA alkaline batteries	2AA alkaline batteries
Pulse duration	10-500µsec	10-500µsec
Pulse frequency	15-350Hz	15-350Hz
Output voltage	20-450v	20-450v
Output current	2-90mA	2-90mA
Waveform	pulsed, damped biphasic sinusoidal	pulsed, damped biphasic sinusoidal

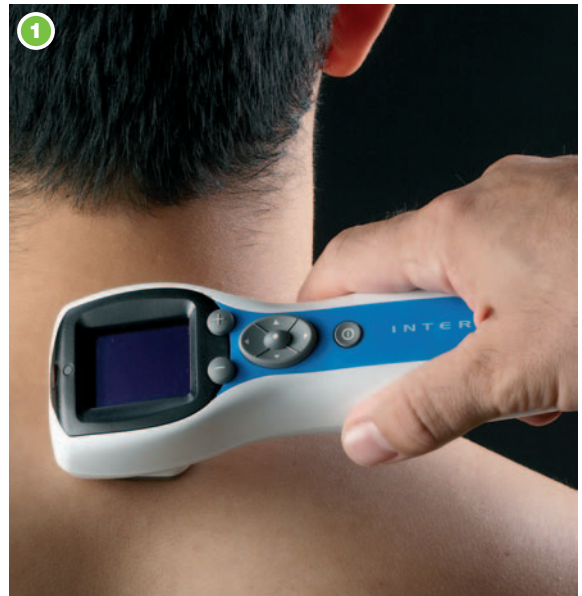

COMB ELECTRODE



DOME ELECTRODE



4 x 4 FLEXIBLE ARRAY ELECTRODE



SOFT TISSUE ELECTRODE



INFORMATION
 Training programs are available by interactive web link.
 Clinical trial data is available, please see www.nrg-unlimited.com for details.



1 Kinetec Portable Low Level Laser System - 670nm / 5mW

This battery powered laser therapy unit is ideal for portable use and clinic use with a unique program system that allows you to select 10 different preset protocols. With an output of 5mW @ 670nm it is ideal for superficial sports injuries and wounds.

Features

- 10 preset protocols
- Continuous and pulsed output
- Uses 2 AA batteries

Standard accessories

This unit is supplied with a control unit, probe, protocol key, operating instructions, treatment guide & hard carry case.

09 131 2032 Laser Therapy Unit with 670nm 5mW probe

Technical Specification	
Base Unit	Battery operated
Class	3A
Output Modes	Continuous and pulsed
Output Power	5mW
Timer	Linked to protocol
Weight	Base & Probe <400g
Dimensions	Base: W 6 x D 3 x H 14cm Probe: Length 17.5cm. 2.5cm Diameter
Power Requirements	2 x AA Battery
Warranty	Unit 1 Year

2 Kinetec Portable Low Level Laser System - 830nm / 160mW

This battery powered laser therapy unit is ideal for portable use & clinic use with a unique program system that allows you to select 10 different preset protocols.

With an output of 160mW @ 830nm it is ideal for musculoskeletal injuries and pain relief etc.

Features

- 10 preset protocols
- Continuous and pulsed output
- Uses 2 AA batteries

Standard accessories

This unit is supplied with a control unit, probe 830nm 160mW, protocol key, operating instructions, treatment guide, hard carry case and 2 pairs of protective glasses.

09 131 2057 Laser Therapy Unit with 830nm 160mW probe

Technical Specification	
Base Unit	Battery operated
Class	3B
Output Modes	Continuous and pulsed
Output Power	160mW
Timer	Linked to protocol
Weight	Base & Probe <400g
Dimensions	Base: W 6 x D 3 x H 14cm Probe: Length 17.5cm. 2.5cm Diameter
Power Requirements	2 x AA Battery
Warranty	Unit 1 Year

The TheraMed SIX Shortwave Therapy System is available as a clinical and portable unit, the clinical model is supplied with a sturdy compact arm, instrument cart and inductive electrode, whereas the portable model offers the therapist a small lightweight unit. The TheraMed SIX combines both highly effective treatment programmes with user convenience, in a single cost competitive therapy system. The base unit uses flexible soft-rubber plate electrodes to deliver capacitive shortwave therapy. For greater treatment flexibility, an optional accessory package can be added to deliver shortwave therapy via an inductive coil applicator - (see clinical model). The instrument cart holds the jointed arm assembly and includes a storage area for all the accessories.

1 TheraMed SIX Clinical Unit

Features

- Highly effective pulsed and continuous shortwave therapy system
- Large LED display
- Can be used with capacitive and inductive applicators
- Extremely low interference
- Fitted with ultra glide castors for maximum manoeuvrability
- Sturdy, compact instrument cart
- Supplied with Trolley Cart, Jointed Arm and Inductive Electrode ϕ 14cm

SWT500 TheraMed SIX

2 TheraMed SIX Portable Model

Features

- Simple to operate
- Lightest high powered pulsed and continuous available
- Easily transported
- Can be used with both capacitive and inductive applicators
- Large LED display
- Extremely low interference
- Supplied with 2 x 12 x 18cm Rubber electrodes and 2 x 75 x 120cm elasticated straps

SWT400 TheraMed SIX Portable Model

Accessories

SWT50 2 - 12 x 18 cm soft-rubber plate applicators with flexible cables

SWT65 2 - 75 x 120cm elasticated straps

SWT100 1 - Instrument cart (For coil applications, all items must be ordered)

SWT200 1 four-joint folding arm

SWT300 1 - 14cm diameter coil applicator
1 special field coil cable

TheraMed SIX Specification	
Input	110 - 240 VAC, 50-60Hz
CE mark	CE 0197
Classification	Protective Class 1 Equipment Type BF Equipment
Weight	Unit 6.8kg Cart 20kg
Dimensions	Unit H 18 x W 36 x D 42cm Cart H 77 x W 48 x D 48cm
Frequency	27,12MHz
HF output	Continuous mode 100 W Average Power Pulsed mode 200 W Peak Power
Pulse frequency	10Hz, 20Hz, 50Hz, 100Hz, 400Hz
Pulse duration range	64 μ s, 100 μ s, 200 μ s, 300 μ s and 400 μ s
Treatment time	1 - 30 minutes



1 Q~Pulse 500

Much better performance for deep-penetrating, shortwave therapy

High Capacity

The powerful Q~Pulse 500 transmits a pulsed, high frequency electrotherapy signal, with a maximum of no less than 70 Watts (1 channel) or 40 Watts per electrode (2 channels).

Equipped with an automatic system that monitors the energy to the patient as soon as an electrode is not in the optimum treatment position anymore, the treatment time pauses and the unit informs the therapist by producing an acoustic and a visual signal.

Thermoplodes

- These special induction electrodes ensure an optimal penetrative effect; no energy is absorbed into the superficial adipose tissue. The Thermoplodes are equipped with a highly technological farady screen, which prevents interference with other appliances.
- The unit is delivered with a Thermoplode with \varnothing 14cm.
- For the treatment of smaller parts of the body (wrist, ankle, knee) the small Thermoplode, \varnothing 8cm is more appropriate (optional).
- Thanks to the 2 independent channels, you are able to connect 1 or 2 Thermoplodes. Also in the case of a combination of a large and a small electrode, the energy emission is automatically adjusted to the diameter of the connected electrode(s). This way you can, for example, treat larger body area or two conditions at the same time.

Features

- Compact shortwave therapy equipment.
- For a-thermal treatment.
- Very high effective and average output.
- 38 scientifically proven indications.
- 50 free memory addresses for personal programs.
- Standard mode for simple and quick start.
- Simple and clear to operate.
- Special Thermoplodes for optimal deep-effect.
- 2 independent channels.
- Contact control for optimising treatment.

114837 Q~Pulse 500

Accessories

114838 Electrode-arm

114840 Thermoplode - \varnothing 14cm

114149 Thermoplode - \varnothing 8cm

114839 High Frequency Cable for Thermoplode



A wide range of applications

Pulsed shortwave therapy is applied specifically in an a-thermal way for acute conditions, inflammations, post-traumatic and post surgical injuries. By setting high pulse repetition frequencies and long pulse times, you will obtain an excellent thermal effect for the treatment of chronic conditions.

Quick start with the Standard Mode

After being switched on, the Q-Pulse 500 automatically starts in standard mode. Because the different parameters have already been pre-programmed, this mode starts your treatment immediately. All that remains for you to do is adjust the power output to the desired level.

More information thanks to the Indication Mode

The Q-Pulse 500 has 38 scientifically proven pre-programmed indications. With the large, centrally positioned rotary button you can smoothly scroll through the list of indications and make your choice.

Applying your own experience with the Free Mode

With the Free Mode you can programme small differences to existing programmes and store them in the 50 free memory addresses for personal programmes.



Practice Furniture

- SIGCOU25** Clarendon Couch
- 100744** Treatment Chair
- MEF035** Treatment Stool





D-ACTOR® Applicator

The D-ACTOR® Applicator can be used with a variety of transmitters for the generation of shockwaves. Each transmitter has its own characteristic effect and area of use. The majority of transmitters generate shockwave, whereas the D20 and S35 transmitters generate both shockwave and vibrations. Transmitters for D-ACTOR® Applicator listed in the table below.

Applications

- Myofascial trigger points
- Other disorders of tendon insertions
- Activation of muscle and connective tissue
- Acupuncture shock wave therapy
- Cellulite treatment (stage I-III)
- Muscle and connective tissue tightening
- Elimination of lymphatic congestion
- Body Shaping
- Regulation of muscle tone
- Medical massage

09 142 5149 D-ACTOR® Applicator



V-ACTOR® Applicator

The V-ACTOR® applicator is an ideal complement to Radial Wave Therapy and contributes to long-lasting treatment results.









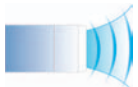

Vibration Treatment

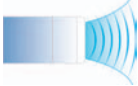
Stimulates metabolism and accelerates the elimination of waste products. Tightens tissue through muscular stimulation. Improves skin firmness to restore a natural, younger appearance. Offers a relaxing wellness experience.

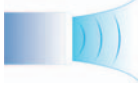
Applications

- Body shaping
- Lymphatic drainage
- Wellness massage
- Muscle and connective tissue activation

09 142 5131 V-ACTOR® hand piece applicator kit that includes the following:
 V25 V-ACTOR® 25mm vibration transmitter
 V40 V-ACTOR® 40mm vibration transmitter

Product	Transmitter	Data	Indications	Energy Flux Density / Penetration Depth	
09 142 4746		C15, 15mm, CERAmA-x® ESWT Transmitter Elastic pressure waves	Gel free, elastic pressure wave therapy for all tendinopathies	 0.45mJ/mm ² 0-40mm	£380.00
09 142 4761		R15, 15mm, EWST Transmitter Radial spreading	Radial pressure wave therapy, all tendinopathies	 0.38mJ/mm ² 0-40mm	
09 142 4787		D20-S, 20mm, D-ACTOR® Transmitter Radial pressure waves and vibration pulses	Myofascial trigger therapy, muscle and connective tissue, dissolution of fibrosis, treatment of deep-seated muscles	 0.48mJ/mm ² 0-50mm	£350.00
09 142 4829		D35, 35mm, D-ACTOR® Transmitter Radial pressure waves and vibration pulses	Myofascial trigger therapy, muscle and connective tissue back muscles, skin elasticity, trigger-diagnosis, dissolution of fibrosis, treatment of deep seated muscles	 0.46mJ/mm ² 0-50mm	
09 142 4845		DI15, 15mm, Deep Impact® Transmitter Energy focused beam	Deep-seated diseases, trigger, chronic conditions, high energy requirements	 0.63mJ/mm ² 0-60mm	£350.00
09 142 4860		F15, 15mm, Focus-Lens Transmitter Energy focused area	Close to surface pain areas, facial muscles, neck, head, individual triggers	 0.16mJ/mm ² 0-20mm	

Intelect RPW

Therapeutic shockwaves were introduced as a medical treatment for eliminating kidney stones without causing skin injury. Today the use of radial shockwaves or Radial Pressure Waves (RPW) has been successfully extended to other applications such as:

- Shoulder calcifications
- Insertional tendonitis
- Muscle trigger points
- Muscle and Connective tissue activation
- Acupuncture therapy
- Lymphatic drainage
- Medical massage

Radial Pressure Waves is an excellent non invasive treatment method with very few negative side effects, for indications that are normally very difficult to treat. For these indications we now know that RPW is a treatment method that reduces pain as well as improves function and quality of life.

Intelect® RPW incorporates touch screen technology to ensure a high degree of simplicity. The easy-to-use menu-driven user interface guarantees reliable selection of all necessary parameters for treatment set-up as well as during patient treatment.

Indications

- Myofascial Trigger Points (MTp)
 - Localising and deactivating trigger points
- Activation of muscle and connective tissue
 - Increasing circulation
 - Pulse Vibration Massage
- Disorder of tendon insertions
 - Plantar Fasciitis, heel pain, or heel spur
 - Tendinosis calcarea/supraspinatus-tendon
 - Radial and ulnar humeral epicondylitis
 - Achillodynia
 - Retropatellar pain syndrome
 - Tibial edge syndrome
 - Proximal iliotibial band friction syndrome/trochanteric
 - Insertional tendonitis

Comes complete with

- Standard Accessory Kit that includes the following:
 - D-ACTOR® Hand piece applicator
 - Projectile (x3)
 - R15 15mm ESWT transmitter
 - D20-S D-ACTOR® 20mm applicator
 - Sealing Set
 - Guide tube (x2)
 - Cleaning Brush
- Conductor™ transmission gel 250mm (8.5oz) bottle (x1)
- Patient Data Card (x1)
- User manual on CD

09 142 5123 Intelect® RPW unit – 230V

**2 YEAR
WARRANTY**



TRANSMITTER STORAGE BOX



REAR VIEW OF TRANSMITTER

Technical Specifications			
Mains Power	230V ~, 50Hz (Model 2074)	Fuses	Two 6.3 A time lag 5 x 20mm (not user serviceable)
Power Consumption	610 VA (Model 2074)	Electrical Class	Class I
Compressed Air Output	1.4 - 5 bar	Electrical Type	Type B
Power Increment Settings	2 bar	Regulatory Risk Class	Ila according to MDD 93/42/EEC The Intelect® RPW has been designed to meet the requirements of IEC/EN 60601-1, 60601-2-3, 60601-1-2 and 60601-1-4
Power Indication	Maximum and average power	Width	42cm (16.5")
Pulse Amplitude	Approx. 2 mm at 3 bar, idling (without coupling)	Depth	41cm (16.14")
Pulse Width	Approx 6 - 12 ms	Height	114.3cm (45")
Pulse Frequency	0.5 - 21Hz	Standard Weight (with 1 handset)	32.66kg (72lbs)
Pressure Vessel Volume	31 l		
Mode	Single or Continuous		

1



1 TPN 200 Plus

Features

- Super tough case
- Simple operation
- Extended battery life
- Variable pulse rate 2Hz - 150Hz
- Variable pulse width 30 μ s - 260 μ s
- Selectable modes: Modulation, Constant, Burst

TPN200A

2 TPN 200 Premier+

Features

- Easy to use
- Flip top cover (stops control movement)
- Extended battery life
- Fully featured timer
- Variable pulse rate 2Hz - 150Hz
- Variable pulse width 30 μ s - 260 μ s
- Selectable modes: Modulation, Constant, Burst

TPN200PP

2



3 TPN 350 TENS

Features

- Large clear digital display
- Adjustable pulse widths 50 μ s - 300 μ s
- Adjustable pulse rate 2Hz - 150Hz
- 5 modes of operation
- Protective control cover
- 5 year warranty (Unit Only)

TPN350

3

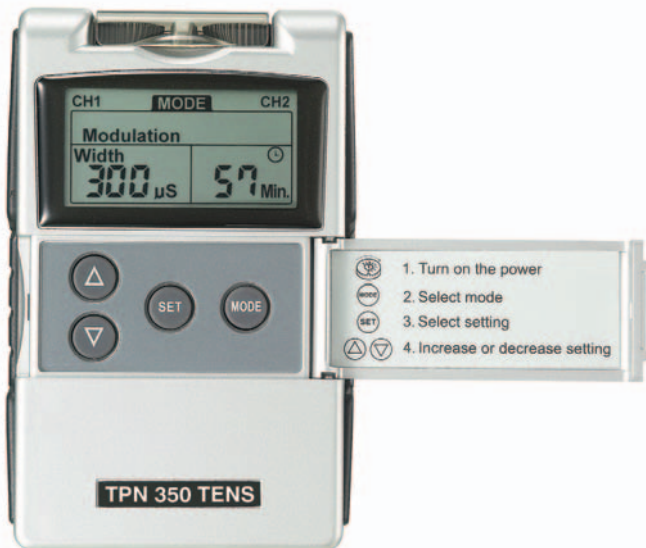

1. Turn on the power
2. Select mode
3. Select setting
4. Increase or decrease setting



INFORMATION

All units are supplied with the following:
 1 x Soft Carry case
 1 x 9V Battery
 1 x Pack of PALS Self-Adhesive Electrodes (4 Electrodes per pack)
 2 x Patient Leads
 1 x Instruction Manual
 Hard Carry Case now supplied as an optional extra.

1 TPNex - Dual Channel TENS

The TPNex Dual Channel TENS manufactured to unrivalled quality. Designed for long term every day use, featuring the latest development in TENS Technology. The TPNex has 9 programmes to treat a wide range of conditions.

The TPNex features

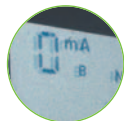

LIQUID CRYSTAL DISPLAY
Shows intensity in mA.



PATIENT COMPLIANCE
Patient treatment time stored automatically.



KEY LOCK FACILITY
(The intensity level can be locked with the simple press of a button, ideal for patients using the TENS during daily activities).



STRONG & STURDY
Virtually unbreakable case with rubber sides for extra protection.



TIMER FACILITY



BURST, CONSTANT MODULATION MODES
Plus 9 preset programmes.

TPN-EX

2 TPN 200 Easy-TENS

The simplest & most straightforward dual channel TENS ever. Just one switch does it all. Simply select one of the 3 frequencies and increase the intensity control to the desired level, that's it!

Features

- Easy to use
- Dual channel output
- Fixed pulse widths 200µs
- Selectable Frequencies:
 - 2Hz Constant
 - 80Hz Constant
 - 120Hz Burst

TPN200EASY



1



1 TPN 800

A dual channel TENS with variable pulse rate, pulse width and a choice of burst, constant or modulation. Comfortable to wear due to its 'landscape' design.

Features

- Pulse width 30µs - 260µs
- Pulse rate 2Hz - 150Hz
- Selectable modes: Modulation, Constant, Burst

TPN800

2 3 Series TENS & EMS

Features

- Large clear digital display
- Choice of TENS or EMS modes
- Easy to use 1 touch operation
- Protective control cover
- 5 year warranty (unit only)

TPN360

3 TPN 400D Birth Assist

Introducing the Birth Assist Obstetric TENS which is designed to bring the drug-free benefits of TENS to pain management. The Birth-Assist is a dual channel unit which incorporates durability with simple operation. Output can be adjusted to each pair of electrodes in response to the patients degree of site pain. The hand held boost control allows for extra pain relief when switched from normal to burst mode to continuous mode with a gradual 3 second 10% lift in power.

Features

- Digital design gives great accuracy
- 10% power boost in contraction mode
- Hand held trigger for burst mode
- Digital display
- Easy to use

TPN400D

2



3



INFORMATION

- All units are supplied with the following:
- 1 x Soft Carry case
 - 1 x 9V Battery
 - 1 x Pack of PALS Self-Adhesive Electrodes (4 Electrodes per pack)
 - 2 x Patient Leads
 - 1 x Instruction Manual
- Hard Carry Case now supplied as an optional extra.

1 MediTENS XP

Versions available for both obstetric and general use - Advanced dual channel digital TENS therapy for pain management

Features

- 5 easy to select TENS programmes
- Combined pain-gate and endorphin release programme targeting chronic pain
- Sweeping TENS programme for targeting acute pain
- 'Trigger' button to maximise pain relief -perfect for obstetric use
- Pulse frequency 4-150Hz
- Pulse width 150µsec
- Intensity lock button
- Belt clip

- 018942** Obstetric
- 09 142 2450** General

2 Economy Dual Channel TENS

A low cost TENS unit that offers all the main features required from a TENS unit but with high quality components to ensure reliability. Standard version includes TENS with case, battery, leads, self adhesive electrodes and operating manual. Deluxe version additionally includes gel and tape.

Features

- Selectable modes: Normal, burst and modulated
- Variable frequency 2-150Hz
- Variable pulse width 30-260µsecs
- Weight 115g including battery

Specification

Base Unit	Internally powered (9V PP3)
No. of channels	2 (isolated) outputs
Output intensity	0-80mA peak,
Dimensions	W 6.5 x D 2.3 x H 9.5cm
Warranty period	3 years - unit only

- S0262** Standard
- S1305** Deluxe
- S1448** Replacement Lead

3 Neen TENS

A dual channel digital TENS unit. Its compact and user friendly design make it perfect for everyday use. It has eight preset programmes and has three customisable programmes so can be tailored to specific patient needs.

Features

- Selectable modes: Normal, burst, modulate
- Variable frequency 2-150Hz
- Variable pulse width 60-250µs
- Patient compliance timer
- Auto switch off after four minutes of non use
- Belt clip
- Dimensions: H 8 x W 6.7 x D 4.5cm

- 012530** TENS Unit
- 013920** Replacement Lead





1 Baxolve XP®

Baxolve is the latest innovative means of controlling back pain using two clinically proven therapies, Lumbar Support and TENS, in one integrated belt.

Baxolve Lumbar Support and TENS can be used together for maximum pain relief or separately, as the situation requires.

Features

- **Easy fastening and adjustment system**
Fitted with a simple Velcro based fastening system with pockets and thumb loops. Baxolve XP® is easy to apply even for elderly patients at home.
- **Developed by experts and clinically tested**
Behind the development of Baxolve XP®, lies years of experience of leading orthopaedic and orthotic experts. Every detail was optimised, checked and validated to ensure the product's compliance with the highest quality standards and the needs of doctors and patients.
- **Skin friendly material suitable to wear all year round**
Baxolve XP® is made from a specially developed very thin elasticated skin friendly material called Flextex™. It has excellent breathability and humidity management characteristics with any excess moisture being quickly carried to the surface where it can evaporate.

Clinical Research

Clinical research has demonstrated that lumbar support and TENS are an effective method of pain relief.

Testimonials

"With an increasing number of people becoming addicted to pain killers due to prolonged back pain, new products which offer drug free relief from back pain are to be welcomed. Baxolve™ combines two clinically proven therapies, TENS and lumbar support, giving the patient control of their pain management and simultaneously easing the burden on the health services". Dr Peter Skew, President of the British Institute of Musculoskeletal Medicine.

	Size	Waist (cm)	Waist (inches)
0217301	1	64-78	25-30
0217302	2	78-92	30-36
0217303	3	92-106	36-41
0217304	4	106-120	41-47
0217305	5	120-142	47-55

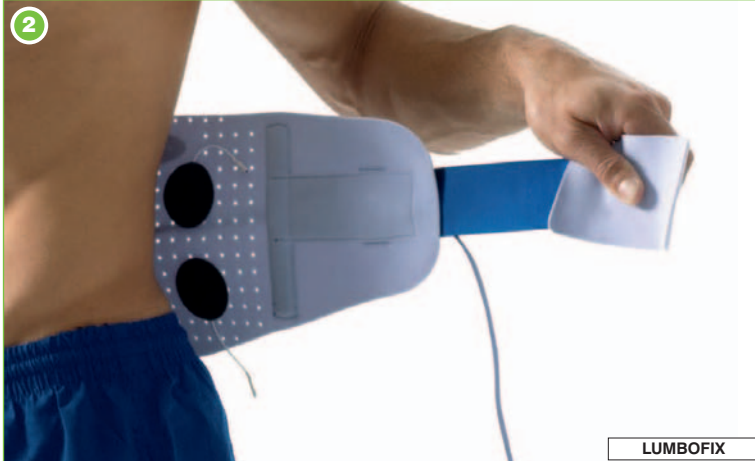

2 Genufix & Lumbifix

The new dimension in patient-friendly electrotherapy. With a 'fix' garment the patient doesn't have to remember where exactly to place the electrode pads.

When pain restricts mobility and patients find it difficult to comply with pad placement advice, treatment outcomes with home based TENS and NMES often suffer.

These new conductive garments have been specifically developed to improve patient compliance by simplifying correct electrode pad placement. Better treatment outcomes are the result.

Features

- Breath-O-Prene® material
 - Latex-free and adhesive-free
 - Unique micro climate control system
 - Stretch and recovery characteristics
- One size fits all
- Thin, low profile construction
- Reusable

Garments are used with Meditens XP (Purchased separately)
Universal connector that allows connection to all TENS machines coming soon - please ask for details.

022204 Genufix TENS applicator for knee

022206 Lumbifix applicator for the back

022205 Genufix/Lumbifix replacement electrodes
5cm diameter. Pack of 4.



INFORMATION
For MediTENS XP, please see page 529.

1 The PALS Back "Belt"

Garments and electrodes for the ultimate, easy-to-use electrical stimulation system.

Easy to use

- Require no assistance for application or removal
- Electrodes stay in place for treatments
- Allows for easy and consistent electrode placement when used at home

Back garment kit includes

- Back garment
- 5 x 5cm Square UltraStim Electrodes. Pack of 4
- Snap Adaptor SN 1004 (no lead wire). Pack of 4

	Waist (cm)
B22-S	63.5-107
B22-L	102-137
US2020	Spare electrodes. Pack of 4.



WITH MOST MODELS OF TENS (PURCHASED SEPERATELY).



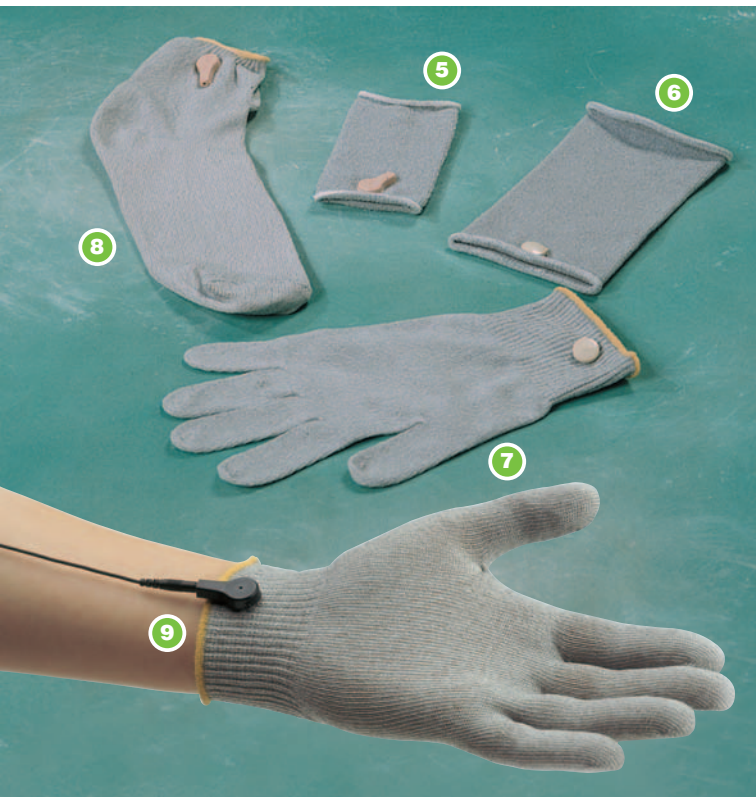

Conductive Garment Electrodes

These NEW conductive garments are manufactured from woven silver nylon. The silver fibres conduct the current throughout the whole garment. Producing an even distribution of stimulation giving maximum comfort and efficiency. All the garments can be used with TENS, Muscle Stimulation and Interferential.

Suitable for:

- Arthritis
- Pain Management
- Tendonitis
- Post operative swelling reduction
- Carpel Tunnel Syndrome
- Circumferential Stimulation

1 Conductive Glove

- HC-885A Large
- HC-884A Medium
- HC-886A Small

2 Conductive Sock

HC-883A

3 Conductive Sleeve (Knee)

Size: 27cm Length, 14cm Wide.

HC-882A

4 Conductive Sleeve (Elbow)

Size: 18cm Length, 12cm Wide.

HC-881A

Theraknit™ Electrodes

Designed to be used in conjunction with pulsed galvanic electrostimulation for muscle stimulation and TENS for reduction of pain and swelling. These garments eliminate guesswork in the size and placement of electrodes - they stimulate the entire involved area for maximum therapeutic effect.

5 Theraknit™ Elbow Sleeve

		Circumference
A939220	Small	15-23cm
A939221	Medium	25-30cm
A939222	Large	30cm

6 Theraknit™ Knee Sleeve

		Circumference
A939230	Small	30-36cm
A939231	Medium	38-46cm
A939232	Large	46cm

7 Theraknit™ Glove

		Palm Width
A939200	Small	Up to 8cm
A939201	Medium	8-9cm
A939202	Large	9-10cm
A939203	X-Large	Over 10cm

8 Theraknit™ Sock

		Shoe Size
A939210		6-9
A939211		10-13

9 Theraknit™ Pigtail-Snap Adaptor

554291

PALS®

PALS wanted to offer the best electrode in the world so they created MultiStick®, a reliable, long-lasting gel that adheres when and where it should time after time...after time

1 PALS® ValuTrode

The PALS ValuTrode offers excellent quality & value for money. Fabric backing & stainless steel electrode leads give these electrodes a very long life span compared to other fabric backed electrodes.

TPN040 5 x 5cm

TPN035 9 x 5cm

2 PALS® TENS Trade Lite

TENS Trade Lite is specifically packaged to give the best price. Packs of 4.

TPN045 5 x 5cm

TPN046 9 x 5cm

3 PALS® Platinum

Features

- Designed for all types of applications
- Unique knitted stainless steel fabric and gel construction
- Ensures an even distribution while reducing current at edging
- Super long lasting knitted construction eliminates 'edge curl'

TPN170 5 x 5cm

TPN175 5 x 9cm

TPN180 3 x 5cm

TPN165 3.2cm Diameter

TPN160 5cm Diameter

4 PALS® Blue

- Has "legs": Gel flows around hair and into the pores of the skin for better skin contact. Improves the gel-to-skin adhesion lowering skin resistance and providing increased stimulation comfort.
- PALS Blue resists dry out: Traditional blue gels require foil packaging as gel dries quickly after opening. PALS Blue is more robust and durable allowing convenient zip lock bag packaging.
- More comfortable and less skin redness when used in conjunction with stimulators that have an unbalanced waveform.

TPN150 5 x 5cm

TPN155 9 x 5cm



Electrotherapy

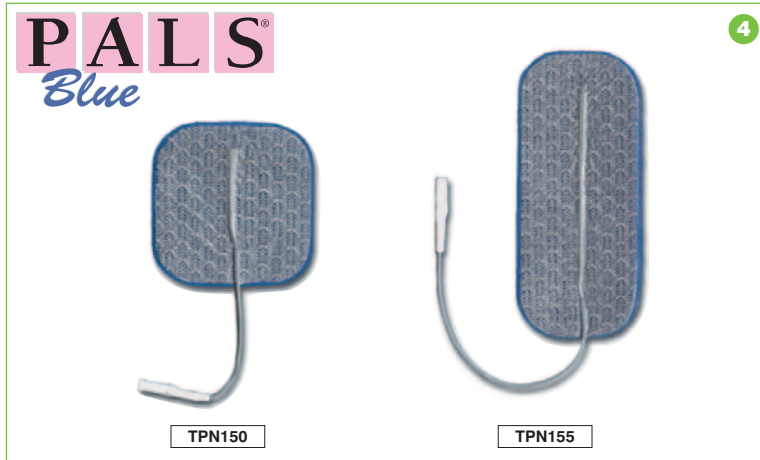

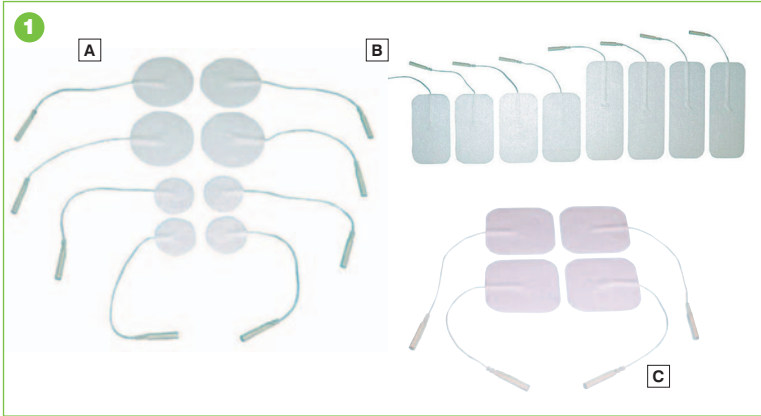

1 Self Adhesive Electrodes

Suitable for all TENS, STIM, FES and EMG applications

- Reusable, comfortable and long lasting
- Offers optimal conductivity and adherence to the skin
- Low allergy gel reduces skin irritation
- Current disperses evenly across the electrode eliminating hot spots
- New carbon wire construction reduces interference for EMG applications

- 012574** **A** 30mm Dia. Round (Pack of 4)
012575 50mm Dia. Round (Pack of 4)
012572 **B** 50 x 90mm (Pack of 4)
221958 50 x 100mm (Pack of 4)
012571 **C** 50 x 50mm (Pack of 4)

2 Super Economy Self-Adhesive Electrodes

Introducing the NEW Super Economy Self-Adhesive Electrodes that are ideal for use with TENS and a wide range of muscle stimulators.

Advantages of the Super Economy Self-Adhesive Electrodes

- Hygienic single patient use
- Eliminates cross contamination
- Comfortable current sensation
- A true low cost disposable electrode

- TPN210** Small 3.2 x 4cm
TPN220 Medium round 5.6cm diameter
TPN230 Medium square 5.6 x 5.6cm
TPN240 Large 12.8 x 5.6cm
CON010/BLACK 2mm socket black
CON010/RED 2mm socket red
CON020 4mm socket

3 Carbon Electrodes

5cm x 5cm carbon electrode with fly lead.

- TPN025A** Pack of 4

4 Re-ply™ Snap Connecting Electrodes

Electrodes are reusable, economical and self-adhering. Low profile design is available in two different sizes. These electrodes can be used for multiple applications up to 14 days.

- 922472** 5 x 5cm Pack of 4
922473 5 x 10cm Pack of 4

5 Reflex Carbon Electrodes

Pre-Gelled Carbon Electrodes

Re-usable, self-adhering, pre-gelled electrodes.

- 09 117 7708** 5 x 5cm
09 117 7716 4.5 x 10cm (High Heat)
09 117 7724 4 x 4.5cm (High Heat)
09 117 7732 4 x 4.5cm

Top Connecting Non-Adhesive Carbon Electrodes

To be used with patches (listed below).

- 09 117 7740** 4 x 4.5cm, Pack of 4
09 117 7757 4 x 10cm, Pack of 4
09 117 7773 4 x 10cm, Pack of 20

Tape Patches

Single use, disposable patches are designed to be used with non-adhesive carbon electrodes (above).

- 09 117 7781** 7.5 x 7.5cm, Pack of 100
09 117 7799 7.5 x 12.5cm, Pack of 100

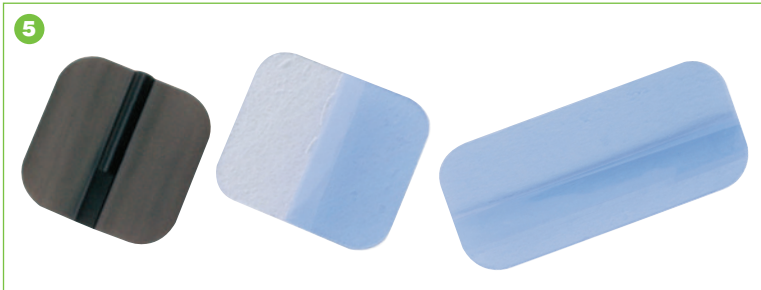
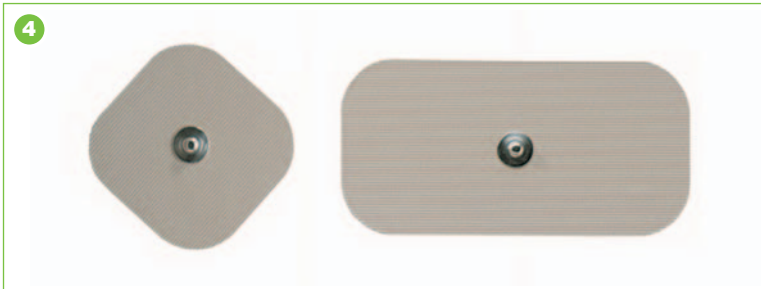
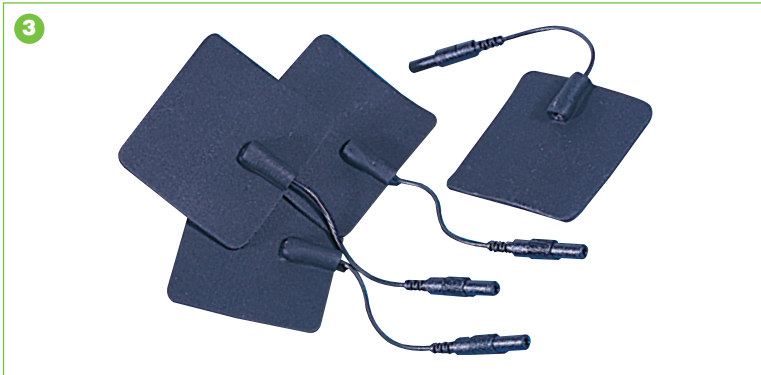
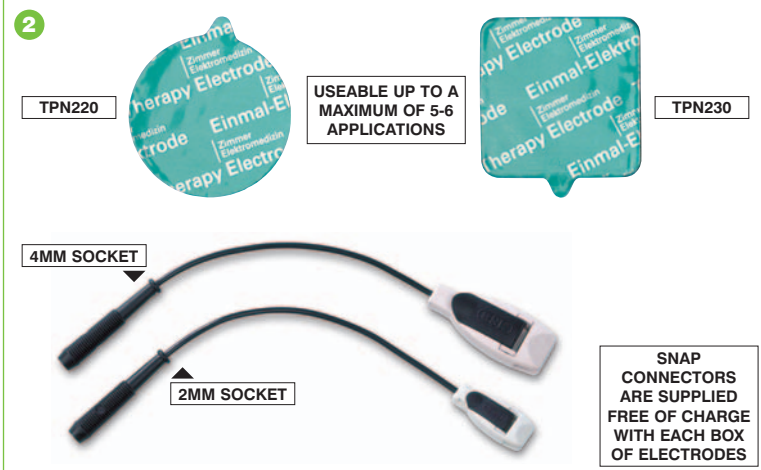

1 UltraStim® Snap Electrodes

UltraStim® Snap patented current control neurostimulation electrodes distribute current evenly and comfortably, enhancing patient comfort. UltraStim® Electrodes are developed with a scientifically calculated grid pattern, printed on a conductive material which precisely controls and optimises the electrical current over the surface of the electrode. The border around the pattern allows for an intentional current drop off. This eliminates edge biting and stinging, resulting in stimulation comfort.

Features

- Bottom snap chosen to match the impedance of the silver pattern.
- Proprietary silver mixture and grid pattern produce the desired current control.
- The areas between the lines of the silver grid pattern are calculated to fill in gaps creating efficient current control.

SN2020	5 x 5cm
SN2040	5 x 10cm
SN2004	White Female Fly Lead
SN1004	Black Snap Connector

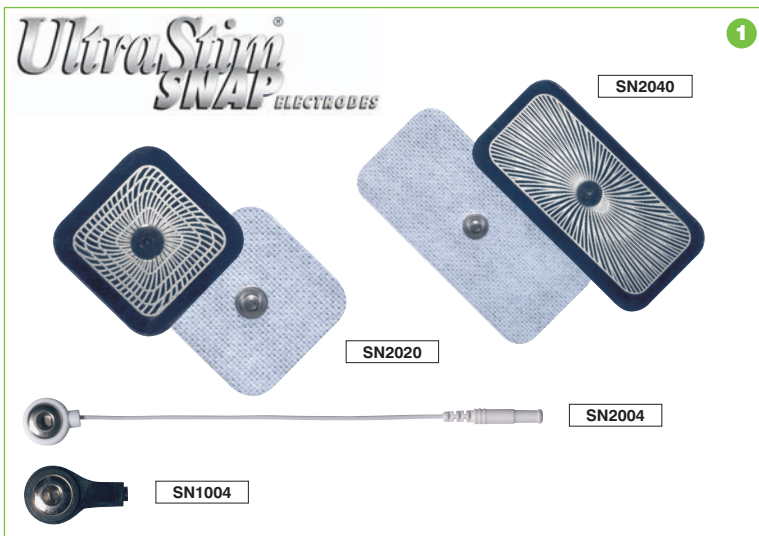

2 UltraStim® Wire Self-Adhesive Electrodes

UltraStim® Wire electrodes distribute the current evenly and comfortably, eliminating hotspots and distributing current evenly and comfortably, enhancing patient comfort.

Features

- Proprietary silver mixture and grid pattern precisely control and optimise electrical current over the electrode surface.
- The areas within the lines of the silver grid pattern are calculated to provide optimum current control.
- Border around the grid pattern allows for an intentional current roll off and eliminates edge stinging.
- Patented 2-layer adhesive hydrogel eliminates performance problems associated with single layer gels.
- Polycoated backing provides an additional moisture barrier.

09 142 8960 4 per pack, 5 x 5cm

09 142 8978 4 per pack, 10 x 5cm



3 Periform®+

- Can be used with most muscle stimulators and biofeedback equipment (refer to manufacturer's instructions before use).
- Single patient use.
- Medical grade surgical stainless steel.
- Unique 'rectangular' section resists lateral movement.
- Contoured electrodes provide comfortable stimulation.
- Smooth clean shape.
- Longer integrated cables.
- Push fit indicator wand with extension pieces.

021972



4 Anuform®

- Revolutionary shape for repeatable positioning and ambulatory use
- Can be used with most muscle stimulators and biofeedback equipment (refer to manufacturers instructions before use)
- Single patient use
- Single orifice use
- Medical grade surgical stainless steel

011503



INFORMATION
For the Neen Pericalm (Stimulation) and Neen Peritone (Biofeedback) units, please see pages 566 to 567.

1

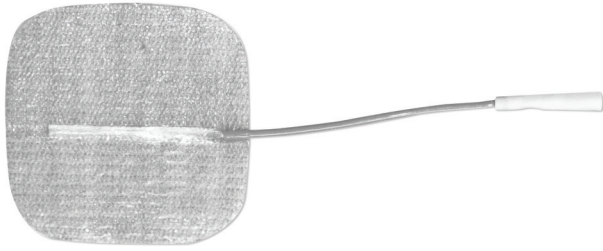

2

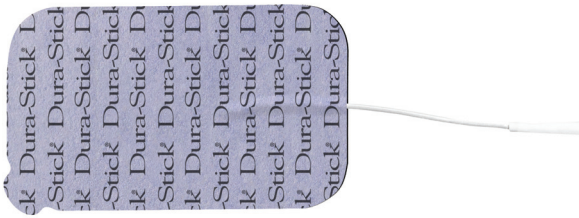

2

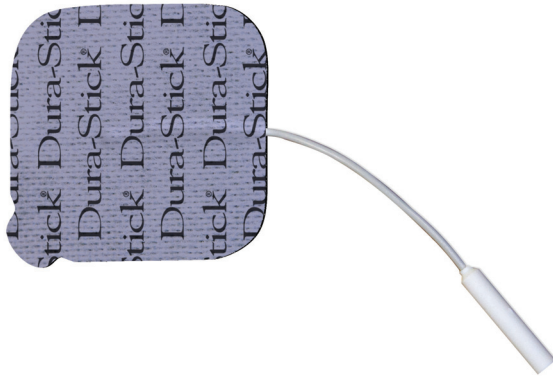

3



1 Dura-Stick® Premium

Stainless Steel Electrodes

- Superior Conductivity
- Pliable material conforms to irregular body contours yet maintains superior conductivity properties

Blue Gel Electrodes

- Multi-layer adhesive gel optimally bonds to the electrode layer and mesh layer
- Gel is formulated to provide multiple applications to sensitive skin

Dura-Stick® Premium					
	Type	Size	Shape	Pack	
09 142 9554	Blue gel	5cm ²	Square	4	£16.00
09 142 9562	Stainless Steel	5cm ²	Square	4	
09 142 9570	Blue gel	4 x 9cm	Rectangle	4	£20.80
09 142 9588	Stainless Steel	4 x 9cm	Rectangle	4	
09 142 9596	Stainless Steel	3.2cm dia	Round	4	£8.75
09 142 9604	Stainless Steel	5cm dia	Round	4	

2 Dura-Stick® Plus

- Precise control and optimisation of electrical current
- Comfortable and effective stimulation is achieved through the electrode
- Available in cloth or foam backing
- Available with lead wires, proprietary Mi snap connection or standard clip

Dura-Stick® Plus						
	Type	Size	Shape	Connector	Pack	
09 142 9612	Cloth	5cm ²	Square	Lead wire	4	£5.50
09 142 9620	Foam	5cm ²	Square	Lead wire	4	
09 142 9638	Cloth	5 x 9cm	Rectangle	Lead wire	4	£7.50
09 142 9646	Foam	5 x 9cm	Rectangle	Lead wire	4	
09 142 9653	Cloth	5cm dia	Round	Lead wire	4	£5.50
09 142 9661	Cloth	5cm ²	Square	Standard clip	4	
09 142 9679	Cloth	5 x 10cm	Rectangle	Standard clip	4	£5.50
09 142 9687	Cloth	5cm ²	Square	Mi Snap	4	
09 142 9695	Cloth	5 x 10cm	Rectangle	Mi Snap	2	£2.75

3 Dura-Stick®

- Cost effective electrodes without sacrificing comfort and performance
- White cloth backing aids in the conformity of the electrode to the skin

Dura-Stick®				
	Size	Shape	Pack	
09 142 9703	5cm ²	Square	2	£3.75
09 142 9711	5 x 9cm	Rectangle	2	
09 142 9729	5cm dia	Round	4	£3.75

1 StarBurst Stimulating Electrodes

These electrodes incorporate a patented multi-layer gradient pattern providing the most advanced current distribution system available. This unique gradient pattern is made of pure silver, known to be a superior conductive material and optimal for stimulating electrodes. Starburst electrodes feature an exclusive hypoallergenic hydrogel with pure aloe vera. The thick hydrogel layer provides superior adherence even after multiple uses. A tinted double-coated liner makes storage easy as electrodes can be returned to either side.

09 142 8986	5cm Square	4 Pack
09 142 8994	5cm Square	40 Pack
09 142 9000	5cm Round	4 Pack
09 142 9018	5cm Round	40 Pack
09 142 9026	7cm Round	4 Pack
09 142 9034	7cm Round	40 Pack
09 142 9042	5 x 10cm Rectangle	4 Pack
09 142 9059	5 x 10cm Rectangle	40 Pack

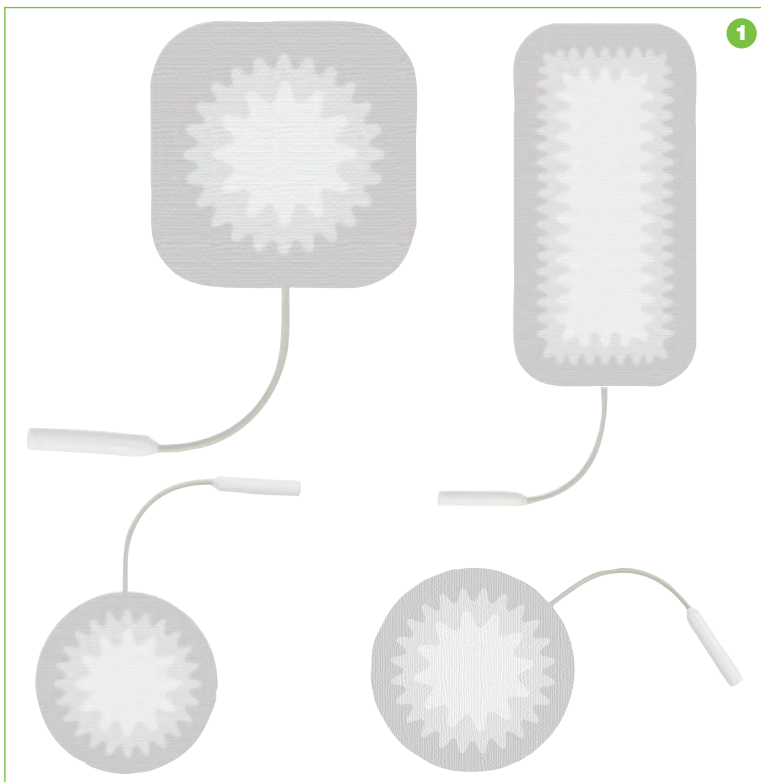

2 Uni-Tab™ Electrodes

Single use electrodes with low profile design. Constructed for clinical applications to promote hygienic treatment. All Uni-Tab™ electrodes require the purchase of an adaptor to attach a standard pin to the electrode tab. Convert a standard 2cm pin to an alligator clip to attach to the tab on the electrode.

09 117 7633	3 x 4cm	Pack of 48
09 117 7641	5 x 5.7cm	Pack of 48
09 117 7658	10 x 5.7cm	Pack of 48
09 117 7666	Black Adaptor	
09 117 7674	Red Adaptor	

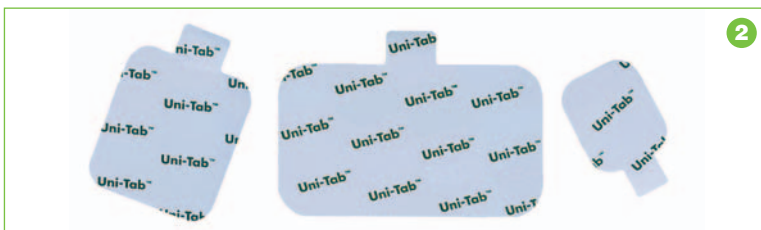

3 Flexible Conductive Rubber Electrodes

Universal Range 4mm shrouded female socket electrode

S0438	4 x 6cm (black)
S0440	6 x 8cm (black)
S0442	8 x 12cm (black)
S0439	4 x 6cm (red)
S0441	6 x 8cm (red)
S0443	8 x 12cm (red)



4 Rubber Electrodes

Rubber Electrodes with pigtails.

S0237	5 x 5cm (pair)
S1790	9 x 5cm (pair)



1



1 Vacuum Electrodes

- 220271** 30mm side entry suction cup small
- S0084** 65mm side entry suction cup medium
- S0083** 95mm side entry suction cup large

2 Vacuum Sponges

Vacuum sponges for use with vacuum electrodes. Single patient use.

- 220275** For 30mm suction cup
- 220045** For 65mm suction cup
- 220046** For 95mm suction cup

3 Mobile Electrodes

A range of mobile electrodes that are insulated on one side so they can be moved during treatment to obtain the best position for treatment and for scanning over muscle.

- S0067** **A** 3" (77mm) round black, 2mm socket
- S0068** 3" (77mm) round red, 2mm socket
- S0069** **B** 2" (50mm) round black, 2mm socket
- S0070** 2" (50mm) round red, 2mm socket
- S0071** **C** 4 x 5cm black, 2mm socket

4 Rubber Electrode Sponge Covers

- S0095** **A** Glove sponge for 4 x 6cm electrodes
- S0094** **B** Glove sponge for 6 x 8cm electrodes
- S0093** **C** Glove sponge for 8 x 12cm electrodes
- S0370** **D** Glove sponge for 3" (77mm) electrodes
- S0371** **E** Glove sponge for 2" (50mm) electrodes

3

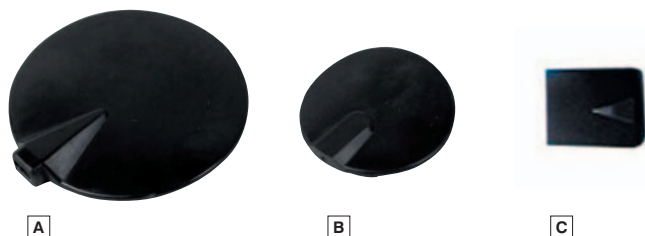

5 Suction Leads

- S0524** **A** (Blue/blue end) 4mm socket
- S0525** **B** (Red/red end) 4mm socket
- 220035** **C** 4mm plug / 4mm socket white
- 220229** **D** 4mm plug / 4mm socket red

4



5

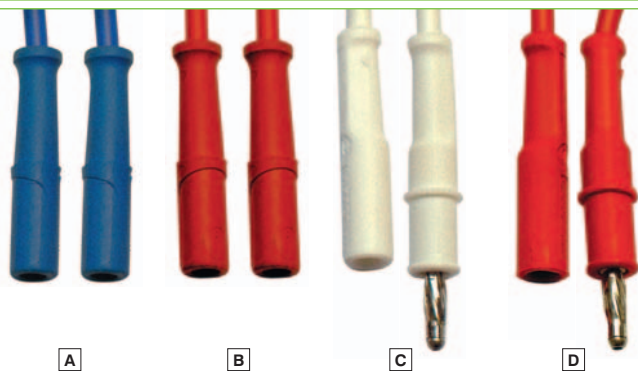

1 Nylatex Wraps

Nylatex Wraps are made from a stretchable, laminated loop material that is ideal for holding electrodes in place to ensure good contact. Pack of 3.

- CHA1202** 6 x 46cm
- CHA1210** 10 x 91cm
- CHA1264** 6 x 61cm
- CHA1212** 10 x 122cm
- CHA1204** 6 x 91cm
- CHA1206** 6 x 122cm
- CHA1208** 10 x 46cm
- CHA1218** 15 x 122cm



2 Adaptors

For converting lead wires to accept different sized electrodes & self adhesive electrodes.

- 015073** **A** 2mm female to 4mm male Adaptor, black
- 015074** 2mm female to 4mm male Adaptor, red
- S0080** **B** 4mm to 2mm Adaptor

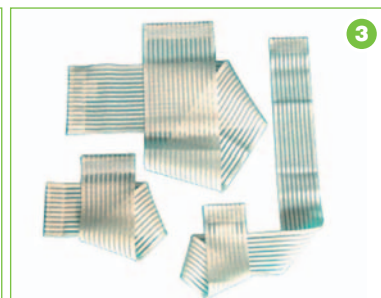

3 Velcro Straps

These Straps are ideal for use on electrotherapy electrodes, ice packs and hot packs. They are manufactured from washable elasticated material with self-fastening velcro hooks.

- S0096** 7.5 x 50cm
- S0098** 7.5 x 120cm
- S0099** 10 x 50cm

4 Fixing Tape

TPN070 1.25cm x 9m



5 TENS-Check Universal TENS Tester

Simple and easy to use, TENS Check comprises two colour coded inputs at the front of the unit. The leads from the TENS machine are inserted and an orange indicator lights on the top of the unit.

Checks:

- Output from TENS unit
- Battery level
- TENS lead continuity

TPN700



1



1 King's Guide to TENS

The first TENS book to offer a straight forward guide to TENS and its applications.

A must for all physiotherapist and patients. A 40 page full colour book, which is well illustrated with a step by step guide to the use of TENS for the treatment of chronic pain.

Covering

- The TENS machine
- What pain is and how can TENS affect it
- Using the TENS machine effectively
- Dermatone maps
- Some common problems
- Where to place electrodes
- A daily routine for TENS
- What to expect
- How long treatments should last
- Exploring low and high frequencies

TPN205

2 Patient TENS Lead

TPN050D

3 Battery Charger and 2 Rechargeable 9v Batteries

TPN1000

4 Battery Charger

TPN102

5 Rechargeable Batteries

TPN101 9v

220869 AA (pack of 4)

6 Standard Batteries

TPN103 9v

022128 Duracell AAAA (pack of 2)

022075 Duracell AA (pack of 2)

022076 Duracell C (pack of 2)

2

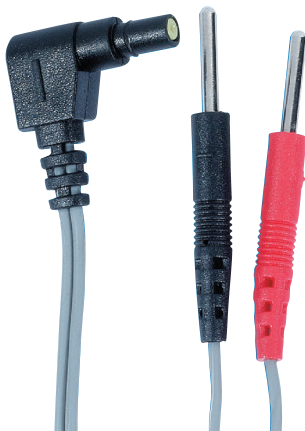

3



5



6



1 Aquasonic® 100 Ultrasound Gel

Aquasonic® 100 is the most widely used gel for diagnostic and therapeutic medical ultrasound. Recommended for all procedures where a viscous gel is required. Hypoallergenic, bacteriostatic and non-sensitising, this gel will not stain clothes, damage transducers or irritate skin.

01-08 250ml

303101 1 Litre

01-50 5 Litre



1

2 48 Aquasonic® Gel Sachets

Aquasonic® 100 Ultrasound Gel in 20g sterile single use pouches for application where sterility is indicated. Pack of 48.

01-01



2

3 Physio-Med Ultrasound Gel

A range of hypoallergenic ultrasound gel available in 5 litre containers or 250ml bottles.

ULS015 5 Litre

ULS020 250ml Bottle

ULS025 Pump dispenser



3

4 Eko-Gel Ultrasound Gel

This ultrasound gel is water-soluble and will not irritate tissue or damage the ultrasound head.

009850 5ltr non rigid container plus free empty 250ml bottle

009731 250ml bottle

S0057 1ltr bottle

S0058 250ml empty bottles x 10

S0259 Pump dispenser to fit 5ltr gel container



4

5 High Conductive Gel 250ml

This High Conductive Gel is excellent for problem applications such as treatment through hair. Especially useful in animal therapy.

220078



5

6 Lectron II Electrode Gel

Ideal for use with muscle stimulators, TENS etc. It will not breakdown or irritate. Available in three sizes.

S0214 60ml Lectron gel

S0590 90ml Lectron gel

S0591 250ml Lectron gel



6

7 Spectra 360® Electrode Gel

The only salt-free and chloride-free electrically conductive gel recommended for all electromedical procedures. Spectra 360 differs from other electrically conductive media. It works by wetting the skin, thereby reducing skin resistance.

- Non-gritty STAY-WET® formula allows for prolonged use without re-application
- Product of choice for ECG, TENS, monitoring and paediatrics
- Non-irritating, hypoallergenic, bacteriostatic
- Product of choice for conductive rubber/carbon electrodes

TPN088 60g

TPN100 250g



7

1



1 Mobile Pro Carry Bag

This bag has been designed for use with the Chattanooga range of machines. It is easy to use, with a simple peel back cover to access all the controls, and when closed ensures that the unit is kept clean and secure. With pockets both sides to store heads and accessories it will make units truly portable. Ideal for use with all Chattanooga machines including combination, ultrasound, interferential and laser.

220312

2 Bags & Cases

A choice of soft padded carry bag or hard carry case. The bag has an extra strong strap and plenty of storage space in its four compartments. The hard carry case is perfect for regular movement of items that require extra protection.

220270 **A** Hard carry case with foam inserts

S0535 **B** Soft padded carry case

3 3 Channel Electroacupuncture Unit

- High performance and versatility.
- 3 independently controllable channels.
- Low/High frequency settings.
- Frequency range 1 - 500Hz.
- Unique wave pulse minimises excessive charge build up in the tissues avoiding nerve damage.
- Complete with 3 patient leads, 1 battery, instructions & soft carrying case

ACC115 3 Channel Electro Acupuncture Unit

2



A



B

3



 For trolleys to store Electrotherapy Machines & Accessories, please see pages 697 to 701.

 For acupuncture needles and accessories, please see pages 339 to 340.

1 Compress Clini Press Unit & Home Press Unit

A True Sequential Compression Unit

A highly effective, non invasive treatment using air compressed on to the limb to move fluids. 'Compress' works with a gentle peristaltic action massaging the limb and effectively aiding the management of oedema due to venous insufficiencies and lymphoedema.

'Compress' is lightweight yet robust and comes complete with garments and connection hoses making this the most cost effective and comfortable, portable unit available today. Ideal for both clinic and home.

- There are 3 pressurisation types (Mode A, Mode B, Mode C).
- A user can select one of three move modes with a move selector according to user's requirements.

Indicated for use in the treatment of:

- Post phlebotic Syndrome
- Varicose veins
- Varicosities of pregnancy
- Leg ulcers
- Venous Ligation
- Knee surgery
- Hand surgery
- Prevention of DVT
- Raynaulds disease
- Arteriosclerosis
- Gravitational Oedema
- Lymphatic Oedema
- Post-Mastectomy Oedema
- After cast-removal
- Flexion contractions

DL2002D Clini Press

DL2002B Home Press

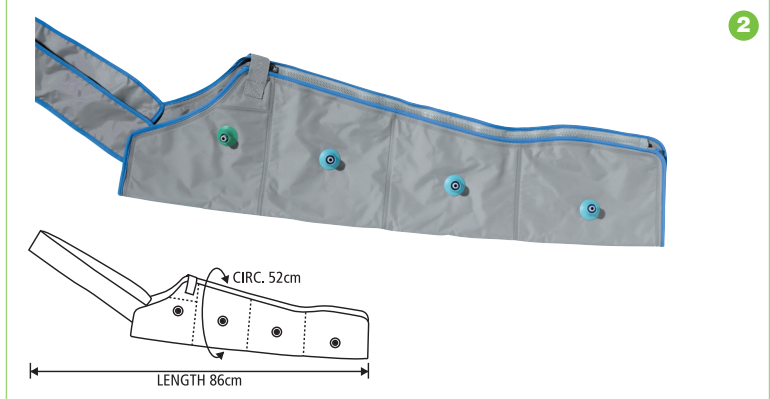

2 Arm Garment

DL2003B Blue

DL2003D Grey

3 Large Leg Garment

DL2004B Blue

DL2004D Grey

4 X-Large Leg Garment

DL2005B Blue

DL2005D Grey

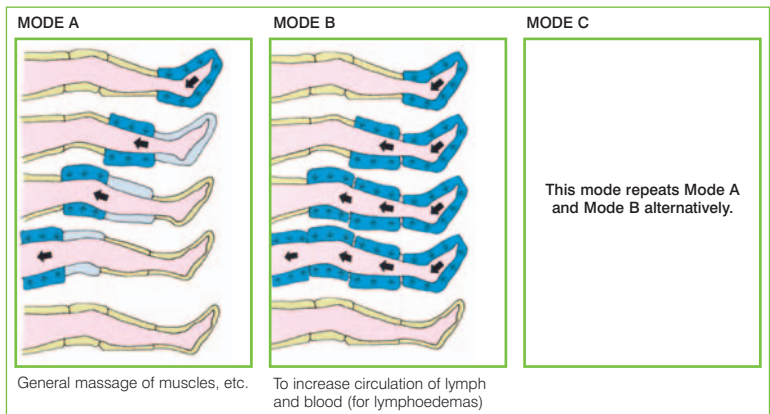
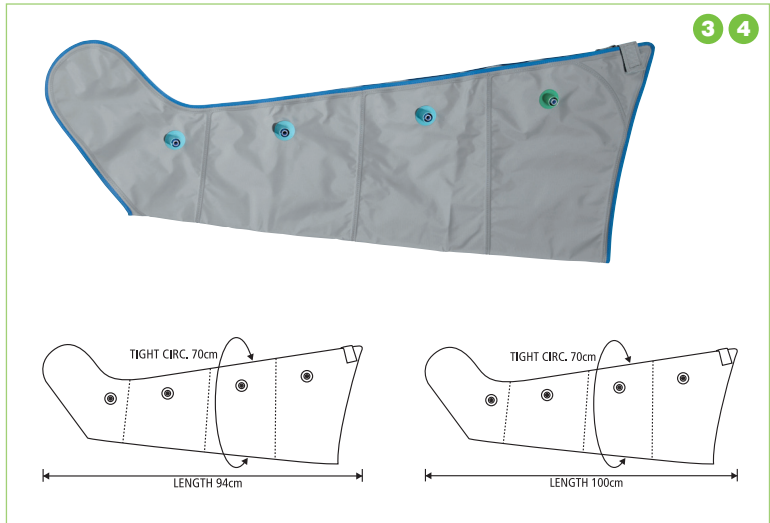

The Pulse Press range of pumps has over 30 years of experience and knowledge built into it. Over this time period there has been a constant effort to improve the products by looking and listening to the market place.

At the heart of every Pulse Press pump unit is a Cyclone compressor. This unit is unique to the Pulse Press range and the key component to giving excellent clinical performance.

All Pulse Press pumps have automatically venting systems should there be a power fail or technical error.

All Pulse Press pumps are designed and manufactured in the UK.

Powerful

- Patented Cyclone compressor
- Rapid garment inflation
- Fast pressure rise times
- Fast garment deflation

Hi-Tech

- Microprocessor controlled
- Adjustable time cycles
- Digital pressure meter

High Quality

- Three year product warranty
- 100% product testing
- Full medical CE approvals

Safety

- Easy to use
- Failsafe automatic deflation

1



1 Pulse Press Mini 3

The Pulse Press Mini 3 pump unit has been designed for the home user.

It is very simple to operate with a pressure setting 20-60 mmHg and a Power switch. A lower output version of the Cyclone compressor is used in the Mini 3 which still gives very good clinical performance.

The system will work with a single garment, which it inflates in a gradient sequential manner. The time cycle is automatically set and is dependant on the garment it is inflating. As soon as the garment reaches the preset pressure then the system deflates.

Both 1 chamber and 3 chamber garment types can be used with this pump unit, which gives the flexibility of more garment styles and lower running costs if 1 chamber garments are chosen.

INC001

2 Pulse Press Multi 3 Pro

The Pulse Press Multi 3 pump unit has been designed to offer the home user a more complete treatment programme.

With adjustable inflate and deflate times the system can be fine tuned to give the exact therapy required by the patient's condition. Other advantages include a more powerful Cyclone compressor for quicker garment inflation, backlit digital pressure meter and soft touch controls. This pump will simultaneously inflate and deflate two garments in a gradient sequential format. The adjustable cycle times allow this unit to treat both venous and arterial leg ulcers very effectively.

Both 1 chamber and 3 chamber garment types can be used with this pump unit. The required hose adaptors are supplied with every pump unit.

INC002

2



For garments, please see page 546.

1 Pulse Press Multi 6

The Pulse Press Multi 6 pump unit has been designed for the professional user.

Once again the Multi 6 pump unit uses the powerful Cyclone compressor to give quick garment inflation. The compressor is controlled by adjustable inflation / deflation controls which allow the treatment to be set exactly to the patient requirement. The 6ch gradient inflation pattern has been proven to work be more effective in the reduction in oedema with patients suffering from lymphoedema. One key advantage of the Multi 6 pump is the extremely fast deflation of the garments. This allows for a much faster cycle time to be set and thus the patient receives more compression cycles per a treatment session.

INC003

2 Pulse Press Multi 12

The Pulse Press Multi 12 pump unit has been specially designed with the clinical user in mind.

The Multi 12 takes the IPC treatment to the next level by integrating a twin cyclone compressor into the enclosure. This helps to give exceptionally fast inflation times.

Other features include the addition of a therapy timer so that predetermined treatments can be completed without the professional being present. The very powerful compressor allows the use of a full lower body trouser garment for patients suffering from extreme lower body lymphoedema. The new 'REMOTE' system has been design to work with the Multi 12 pump unit and allows the patient to start and stop a therapy as well as set the treatment time.

INC004

3 Pulse Press Multi 12 Auto

The Pulse Press Multi 12 Auto pump unit has been designed for the clinical user.

Ease of use has been the primary design of the Multi 12 Auto, whilst still delivering an outstanding therapy. The same twin Cyclone compressor as used in the Multi 12 pump ensures unrivalled performance whilst the single mode selection automatically sets the inflation, deflation and therapy timer settings. During operation the patient can see the progress of the cycle by the blue LED bar graph. Again the 'REMOTE' hand control has been designed to work in tandem with this system to offer greater patient comfort.

09 143 4224



1

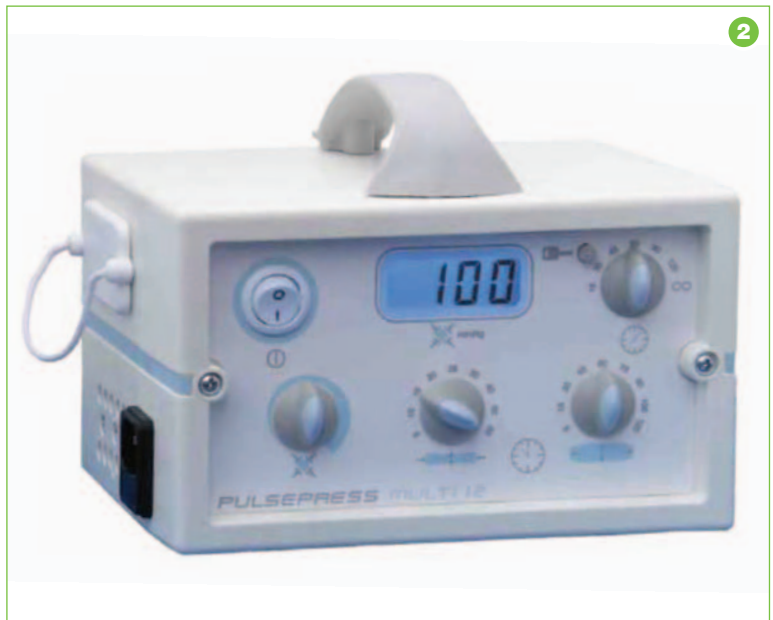

2



3



1 Pulse Press Garments

Pulse Press Garments are available in single, 3, 6 and 12 chamber versions. Multi-chamber garments are designed to automatically adjust to the size of the patient's limbs, therefore no alteration is required as the treatment progresses.

The entire Pulse Press range of garments is machine washable helping to prevent cross infection and improve garment hygiene.

Features:

Machine Washable to 95C

- Prevents cross infection
- Labour saving
- Improved garment hygiene

Auto Adjusting

- Garment design means no adjusting or fitting to patients

Exclusive Material

- Specially formulated PU coated nylon.

- Hard wearing

- Lightweight

High Quality Hoses

- Soft and flexible
- Kink resistant

Easy to use

- Large pull ring on zippers
- Simple hose connectors

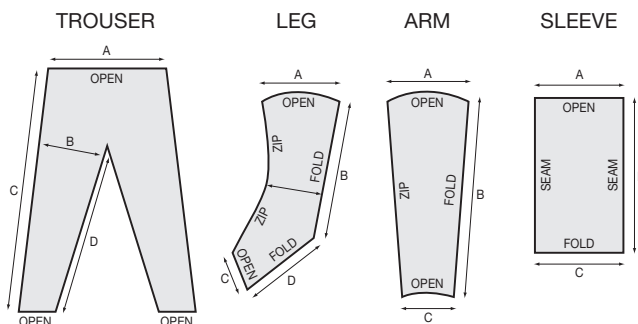

Pulse Press Garments						Measurements				
Code	Description	Chambers	Pump			A	B	C	D	E
09 142 9471	Knee Sleeve	1	Mini 3	Multi 3 Pro		55	33	50		
INC070	Hand & Wrist	1	Mini 3	Multi 3 Pro		40	38	64		
AA9290E	Half Arm	1	Mini 3	Multi 3 Pro		50	43	42		
AA9290B	Half Leg	1	Mini 3	Multi 3 Pro		60	50	30	31	50
09 142 9489	Half Arm	3	Mini 3	Multi 3 Pro	Multi	50	43	4		
AA9291A	Wide Long Arm	3	Mini 3	Multi 3 Pro	Multi 6	60	76	47		
AA9291B	Half Leg	3	Mini 3	Multi 3 Pro	Multi 6	60	50	30	31	50
INC125	Long Leg	3	Multi 3 Pro	Multi 6		70	74	30	31	50
INC145	Wide Long Arm	6	Multi 6	Multi 12	Multi 12 Auto	60	76	47		
09 142 9497	Long Arm & Shoulder	6	Multi 6	Multi 12	Multi 12 Auto	60	76	47		
AA9291E	Wide Long Leg	6	Multi 6	Multi 12	Multi 12 Auto	80	84	30	31	53
09 142 9505	Wide Trouser	6	Multi 6	Multi 12	Multi 12 Auto	130	76	137	94	
INC146	Wide Long Arm	12	Multi 12	Multi 12 Auto		60	76	47		
09 142 9513	Long Arm & Shoulder	12	Multi 12	Multi 12 Auto		60	76	47		
INC147	Wide Long Leg	12	Multi 12	Multi 12 Auto		80	84	30	31	53
09 142 9521	Wide Trouser	12	Multi 12	Multi 12 Auto		130	76	137	94	

Clinic Furniture

666 - 681 Couches & Plinths
676 - 677 Traction
682 - 683 Paper Towels
684 Couch Covers
685 Couch Accessories
686 - 687 Changing
688 - 689 Tilt Tables

690 - 693 Chairs & Stools
694 - 695 Screens & Mirrors
696 Waste Bins
697 - 701 Trolleys & Cabinets
702 Workstations
703 Arm Tables & Easels
704 - 709 Work Tables
710 - 714 Steps, Ramps & Stairs
715 Pulleys
716 - 717 Parallel Bars
718 - 719 Suspension Frames,
Wall Bars & Benches
720 Standers
721 Lamps
721 - 723 Hardware
724 - 726 Domiciliary Equipment
727 - 728 Reality Orientation



Premier+ Couches

Premier+ Couches are manufactured to the highest standard for the healthcare industry and offer quality, value for money and reliability.



Premier+ 2 Section Couch

Features

- Single gas strut configuration at the head section provides an ultra smooth operation
- Twin lift construction gives unparalleled stability
- Height adjustment from 46cm to 95cm
- Head section adjustment from -30° to 85°
- Ergonomic breathing hole with plug as standard
- Clearance of 12.5cm for a mobile hoist
- Open base design
- 4 robust castors for ease of placement
- 4 levelling feet to aid stability
- Electric and hydraulic versions available in 5 colours

PPS115MEM	Electric	Blue
PPS115BEI	Electric	Beige
PPS115NUB	Electric	Black
PPS115ASH	Electric	Grey
PPS115SPR	Electric	Spruce
PPS105MEM	Hydraulic	Blue
PPS105BEIGE	Hydraulic	Beige
PPS105NUB	Hydraulic	Black
PPS105ASH	Hydraulic	Grey
PPS105SPR	Hydraulic	Spruce
TAB250	Couch Roll Holder	
09 142 4902	Cot Sides	

Maximum user weight **190 kg** **30 st**

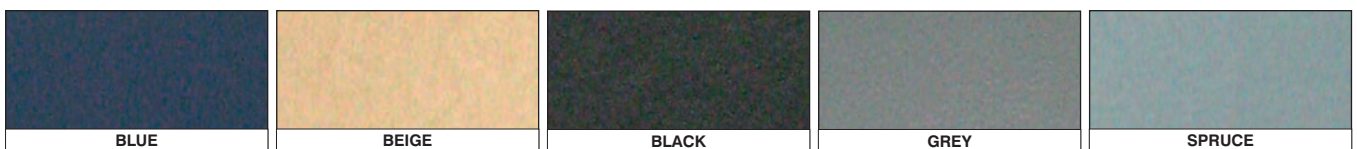

Colours are as accurate as the printing process will allow.

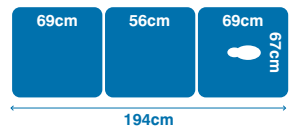

Premier+ 3 Section Couch

- Single gas strut configuration at the head and foot section provides an ultra smooth operation
- Twin lift construction gives unparalleled stability
- Height adjustment from 46cm to 95cm
- Head section adjustment from -30° to 85°
- Ergonomic breathing hole with plug as standard
- Clearance of 12.5cm for a mobile hoist
- Open base design
- 4 robust castors for ease of placement
- 4 levelling feet to aid stability
- Electric and hydraulic versions available in 5 colours

PPS135MEM	Electric	Blue
PPS135BEIGE	Electric	Beige
PPS135BLACK	Electric	Black
PPS135ASH	Electric	Grey
PPS135SPRUCE	Electric	Spruce
PPS125DARK BLUE	Hydraulic	Blue
PPS125BEIGE	Hydraulic	Beige
PPS125BLACK	Hydraulic	Black
PPS125 GREY	Hydraulic	Grey
PPS125 SPRUCE	Hydraulic	Spruce
TAB250	Couch Roll Holder	
09 142 4902	Cot Sides	

Maximum user weight **190 kg** **30 st**

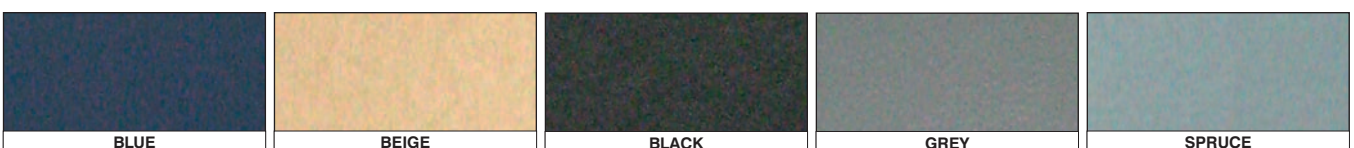

Colours are as accurate as the printing process will allow.

1



1



1 Paediatric Couch

This paediatric two section couch is brightly coloured making it fun for children and aiding compliance.

- High quality 2 section universal couch
- Twin lift design
- Electric and hydraulic models available
- Hand control operation on electric model
- Positive/negative head section from -20° to +90°
- Mobile hoist clearance 16cm
- Breathing hole and plug
- Height adjustment 50 - 92cm
- Padded cost sides as standard
- Upholstery: Length 188cm (74") Width 65cm (25")

09 120 1110

Maximum user weight



DELIVERY

Delivery is approximately 3 to 4 weeks. Please contact Customer Services for more information.



MADE TO ORDER

This item is made to order and, therefore, is not refundable.

1



1 Wide Neurology Couch

This wide neurology plinth has been designed to give excellent rigidity and stability. The wider top allows the therapist to undertake a range of neurological treatments alongside the patient. The low operating height is ideal for patient transfers and balance study techniques and the backrest is adjustable from -20° to 85°

Features:

- 4 heavy duty retractable castors
- 4 individual levelling feet
- Gas strut head section as standard
- Twin lift stability
- Available in 3 colours

09 132 6073 Blue
09 132 6081 Beige
09 132 6222 Spruce

Maximum
user weight



Colours are as accurate as the printing process will allow.



1 Akron Streamline™ Popular Couch

The Popular provides strength and rigidity, minimal maintenance and long life.

Features

- Extremely strong and rigid
- Choice of hydraulic or electric height operation
- Hand switch height control on electric models
- Breathing hole and plug as standard
- Retractable wheel base as standard
- Positive and negative head section angles +80° to -18°
- Mobile hoist compatible
- Self lubricating bearings
- Standard width 64cm
- Height range 46 to 91cm
- Choice of upholstery colours
- Hinge covers

Colour	Electric UK Plug	EU Plug	Hydraulic
Blue	09 113 5029	09 117 0521	09 113 5060
Beige	09 113 5045	09 117 0547	09 113 5086
Dark Blue	09 113 5052	09 117 0554	09 113 5094
Grey	09 113 5037	09 117 0539	09 113 5078

Maximum user weight **225 kg** **35 1/2 st**



2 Akron Streamline™ Continental Couch

The versatile Continental Couch is suitable for a wide range of manual therapy techniques, various medical procedures, massage and complimentary medicine. Height range 44 to 93cm.

Features

- Extremely strong and rigid
- Choice of hydraulic or electric height operation
- Hand switch height control on electric models
- Breathing hole and plug as standard
- Retractable wheel base as standard
- Mobile hoist compatible
- Adjustable angle backrest from horizontal to +80°
- Positive and negative foot section angles +80° to -18°
- Self lubricating bearings
- Standard width 64cm
- Height range 46 to 91cm
- Choice of upholstery colours
- Hinge covers

Colour	Electric UK Plug	EU Plug	Hydraulic
Blue	09 113 5201	09 117 0604	09 113 5243
Beige	09 113 5227	09 117 0612	09 113 5268
Dark Blue	09 113 5235	09 117 0620	09 113 5276
Grey	09 113 5219	09 117 0638	09 113 5250

Maximum user weight **225 kg** **35 1/2 st**



3 Fold Down Cot Sides

These Fold Down Cot Sides provide additional patient safety. Popular Couch requires 89cm and Continental Couch requires 65cm. Chrome plated. Sold in pairs.

AA95115A 89cm

AA95115B 65cm



4 Cot Side Pads

Pads that can be quickly and simply secured to the cot sides above, providing additional comfort for the patient.

AA95116A 89cm

AA95116B 65cm

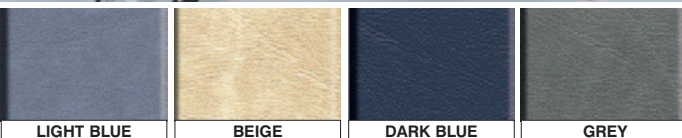

Colours are as accurate as the printing process will allow.

DELIVERY
Delivery is approximately 3 to 4 weeks. Please contact Customer Services for more information.

MADE TO ORDER
This item is made to order and, therefore, is not refundable.

1 Akron Bobath Plinth

Specifically designed for the rehabilitation of patients diagnosed with various neurological conditions. The enhanced rigidity and large upholstered top allows for the performance of treatment techniques and exercises, with room for both patient and therapist. The low operating height of 46cm is excellent for patient transfers and for balance and standing techniques. The backrest is adjustable from horizontal to 85° and provides support during both lying and sitting exercises. Hydraulic models are operated by a foot lever for height adjustment, whilst electric models have a hand control. Height adjustable 46-91cm.

Features

- Variable height control: hydraulic or electric
- Retractable wheelbase
- Positive angled head section
- Mobile hoist compatible
- Adjustable foot for uneven flooring
- Strong and rigid design

Akron Bobath Plinth			
Colour	Electric		Hydraulic
	UK Plug	EU Plug	
Blue	09 113 5409	09 117 0745	09 113 5441
Beige	09 113 5425	09 117 0752	09 113 5466
Dark Blue	09 113 5433	09 117 0760	09 113 5474
Grey	09 113 5417	09 117 0778	09 113 5458

Maximum user weight **225 kg** **35 st**  

2 Akron Bobath 5

The Bobath 5 addresses the lifting and handling problems associated with very heavy patients. The increased safe working load of 325kgs and the electrically powered backrest facility provide the clinician with a safe means of raising and positioning the patient for medical examinations and procedures. Patient support handles or loops can be added to further assist the patient into a sitting or standing position either before or after treatment. The large wheel system, with steering facility also enables movement or transport of the 'on board patient' around clinic or ward. Height adjustable from 50 to 96cm. Backrest adjustable from 0° to 85°.

Features

- Safe working and lifting capacity of 325kgs
- Electrically powered backrest
- Both height and backrest angle can be operated in combination via two way hand switch
- Electric variable height with battery backup
- Large wheel system with steering facility
- Mobile hoist compatible

Akron Bobath Plinth		
Colour	Electric	
	UK Plug	EU Plug
Blue	09 113 5482	09 117 0828
Beige	09 113 5508	09 117 0836
Dark Blue	09 113 5516	09 117 0844
Grey	09 113 5490	09 117 0851

Maximum user weight **325 kg** **51 st**  

Optional Accessories

- AA95150** Chrome Plated Fold Down Cot Sides - Pair
- AA95116A** Cot Side Pads - Pair
- AA95124** Support Loops - Pair
- AA95123** Support Handles Pair
- AA95125** Arm/Leg Support Attachment with Angular Adjustments
- AA95126** Knee Support Block and Harness

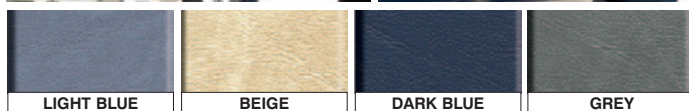

Colours are as accurate as the printing process will allow.

 **DELIVERY**
Delivery is approximately 4 to 6 weeks. Please contact Customer Services for more information.

 **MADE TO ORDER**
These items are made to order and, therefore, are not refundable.



1

186cm
125cm



2

180cm
120cm

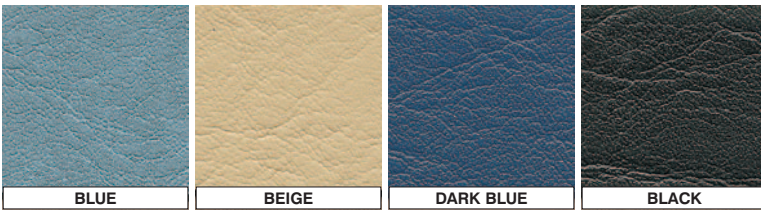

Colours are as accurate as the printing process will allow.



3

183cm
92cm



1 Mat Platform Homecraft

Designed to accommodate a variety of therapeutic treatments that require extra width and a greater working surface.

- Twin lift design
- Constructed from robust steel for maximum stability and strength
- Electric and hydraulic models available
- Hand control operation on electric model
- Clearance of 23cm for a mobile hoist
- Height adjustment 50 - 92cm (19 - 36")
- Upholstery dimensions: Length 186cm (73"). Width 125cm (49").

AA9514EB	Electric	Blue	UK Plug
AA9514EH	Electric	Beige	UK Plug
AA9514EK	Electric	Dark Blue	UK Plug
AA9514EG	Electric	Black	UK Plug
09 115 7114	Electric	Blue	EU Plug
09 115 7122	Electric	Beige	EU Plug
09 115 7148	Electric	Dark Blue	EU Plug
09 115 7155	Electric	Black	EU Plug
AA9514HB	Hydraulic	Blue	
AA9514HH	Hydraulic	Beige	
AA9514HK	Hydraulic	Dark Blue	
AA9514HG	Hydraulic	Black	

Maximum user weight **225 kg** **35 1/2 st**



2 Bariatric Platform Homecraft

The Bariatric Platform is an extremely robust, high quality platform that has a safe working load of 300kg (47st). It has an extra large working surface and the electrical raising and lowering mechanism is extremely smooth. Constructed from strong steel, it has a reinforced twin lift base for maximum strength and stability. Available in four colours. Choose from a hand controller or foot controller. Height adjustment 54 - 96cm (21 - 37"). Upholstery dimensions: Length 180cm (70"). Width 120cm (47").

	Controller	Colour
AA95141B	Hand	Blue
AA95141K	Hand	Dark Blue
AA95141H	Hand	Beige
AA95141G	Hand	Black
AA95142B	Foot	Blue
AA95142K	Foot	Dark Blue
AA95142H	Foot	Beige
AA95142G	Foot	Black

Maximum user weight **300 kg** **47 st**



3 Low Wide Exercise Table

An extra wide, low, fixed height exercise table that provides a greater range of movement and safety. Supplied in beige, flame retardant vinyl upholstery. Supplied flat packed. Height 46cm. Length 183cm. Width 92cm. Weight 38kg.

AA9531
Maximum user weight **140 kg** **23 st**



NDD UK NEXT DAY DESPATCH
Delivered from stock. Please contact Customer Services for more information.

DELIVERY
Delivery is approximately 3 to 4 weeks. Please contact Customer Services for more information.

MADE TO ORDER
This item is made to order and, therefore, is not refundable.

1 Split Leg Orthopaedic Couch

A high quality Orthopaedic Couch with split legs, and a range of accessories ideal for use in Plaster Rooms.

- Electric model as standard
- Hand control operation on electric motors
- Gas strut adjustable leg and back rest
- Positive back section to 85°
- Negative leg section - 90° to + 15°
- Telescopic leg sections for taller patients
- Telescopic arm rests
- Clearance for a mobile hoist is 17.5cm
- Choice of upholstery colours
- Height adjustment: 48-96cm

- 09 119 1006** Black
09 142 2682 Beige
09 142 2690 Blue
09 142 2708 Dark Blue

Maximum user weight 

Upper Limb Cast Support – Fully adjustable arm support, can be fitted on either side of the couch.

- 09 119 1048** Black
09 142 2716 Beige
09 142 2724 Blue
09 142 2732 Dark Blue

Seat Riser – Provides maximum support and access when applying full length dressings and casts.

- 09 119 1055** Black
09 142 2740 Beige
09 142 2757 Blue
09 142 2765 Dark Blue

Lower Limb Cast Support – Height and angle adjustment allows excellent access for lower limb procedures. Can be fitted to either side of the couch.

09 119 1071

Instrument Tray

Useful tray for holding instruments while working. Can be fitted to either side of the couch.

09 119 1089

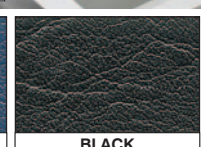
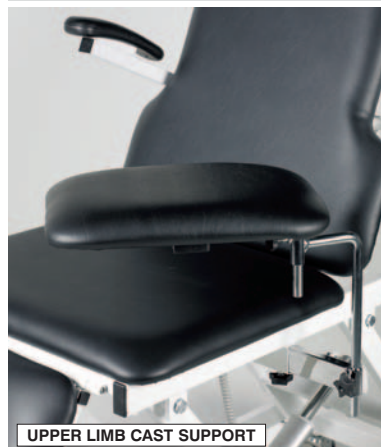

Colours are as accurate as the printing process will allow.

DELIVERY
 Delivery is approximately 3 to 4 weeks. Please contact Customer Services for more information.

MADE TO ORDER
 This item is made to order and, therefore, is not refundable.

1



39.5cm 49.5cm 64cm 89cm

NEW

1 Ultrasound Couch

Our new Ultrasound Couch offers great value with smooth electric operation of height, tilt and backrest angle (3 motor only). It is ideal for both supine and seated procedures.

Features:

- Strong stable twin lift design
- Available with 2 or 3 motors
- Hand control operation for motors
- Gas strut operation on footrest (and backrest for 2 motor version)
- Trendelenburg tilt facility
- Anti-bacterial frame and upholstery (available in 4 colours)
- Positive back section to 85°
- Negative leg section -90° to +15°
- Height range 51-89cm
- Retractable wheels
- Hoist clearance 17.5cm

	Type	Colour
09 142 2849	3 Motor	Beige
09 142 2856	3 Motor	Black
09 142 2864	3 Motor	Blue
09 142 2872	3 Motor	Dark Blue
09 142 2880	2 Motor	Beige
09 142 2898	2 Motor	Black
09 142 2906	2 Motor	Blue
09 142 2914	2 Motor	Dark Blue

Maximum user weight



1



NEW

1



NEW

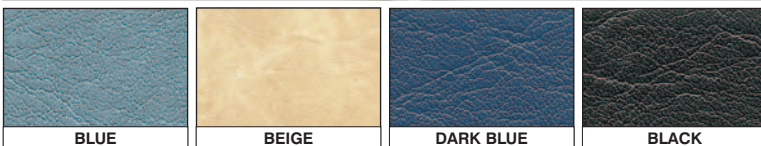

3-4 wks DELIVERY
Delivery is approximately 3 to 4 weeks. Please contact Customer Services for more information.

MADE TO ORDER
This item is made to order and, therefore, is not refundable.

1 Podiatry Couch

Designed specifically for podiatry use within both private practise and the NHS. Available in 2 models with features that have been designed with patient and practitioner comfort in mind.

Features:

- Strong stable twin lift design
- Available with 2 or 3 motors
- Hand control operation for motors
- Gas strut operation on footrests (and backrest for 2 motor version)
- Trendelenburg tilt facility
- Telescopic leg sections for taller patients
- Telescopic arm rests
- Anti-bacterial frame and upholstery (available in 4 colours)
- Positive back section to 85°
- Negative leg section -90° to +15°
- Height range 51-89cm
- Retractable wheels
- Hoist clearance 17.5cm

	Type	Colour
09 132 7295	3 Motor	Beige
09 132 7311	3 Motor	Black
09 132 7287	3 Motor	Blue
09 132 7303	3 Motor	Dark Blue
09 132 7253	2 Motor	Beige
09 132 7279	2 Motor	Black
09 132 7246	2 Motor	Blue
09 132 7261	2 Motor	Dark Blue

Maximum user weight **260 kg** **40 st**



3-4 wks DELIVERY
Delivery is approximately 3 to 4 weeks. Please contact Customer Services for more information.

MADE TO ORDER
This item is made to order and, therefore, is not refundable.

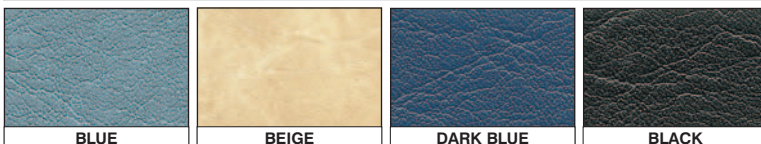

Colours are as accurate as the printing process will allow.



1 Accutrac Traction Unit

The Accutrac Traction Unit is extremely easy to operate yet offers all the features required from a top quality traction unit.

- Easy to read displays
- Intermittent and static traction
- Variable speed control
- Minimum and maximum force settings 2.5-91kgs
- Patient safety switch with adjustable alarm

MET670

2 Accessories

- TAB200** A Thoracic Traction Belt
- TAB195** B Pelvic Traction Belt
- TAB205** C Head Halter
- TAB220** D Traction Straps Set
- TAB225** E Cord Extension 2.5cm min length and 180cm max length
- TAB210** F Spreader Bar
- TAB226** Cervical in sitting attachment

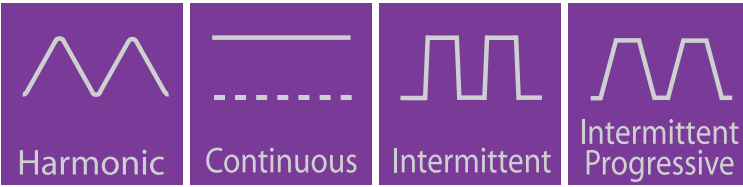

Technical Specifications	
Power Supply - Voltage	100/120/220/240 Volts 50/60Hz
Traction Force	200lb/91kg Max. 5lb/2.5kg
Traction Force Compensation	Computerised automatic compensation
Force Display	Actual force/preset force - automatic switching display
Traction Speed	Stepless, continuous and adjustable
Therapy Mode	Continuous/intermittent/harmonised intermittent/progressive
Treatment Time	1 to 99 minutes 2%
Current	1.2a(100v, 120v), 0.6a(220v, 240v)
Power Consumption	150va max
Allowable Voltage Fluctuation	Max 10%
Mains Fuses	F 1.6a 250v (for 100v, 120v); F0.8a 250v (for 220v, 240v)
Casing Leakage of Electricity	<100 A
Ground Resistance	<0.1
Continuous Traction/Release Time	0 To 99 seconds 2%, independently set
Safety System	Multiple protection alarms - Service/overload/min>max/remote
Electrical Safety Degree	Class I / type Bf (Iec 60601-1)
EMC Tested	Iec 60601-1-2 requirements
Classification of Equipment	Class Iib as per MDD 93/42/EEC Annex IX
CE Marking	CE 0197

1

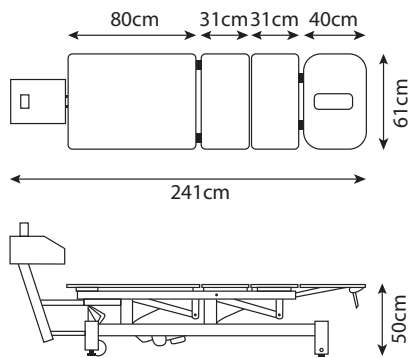

1 Physio-Med Universal Traction System

For continuous and intermittent cervical and lumbar traction. Physio-Med's Universal Traction System can be set to continuous or intermittent traction force.

The package includes: accutract traction unit, flexion stool and all traction harnesses.

Features:

- 4 heavy duty retractable castors
- 4 individual levelling feet
- Gas strut head section as standard
- Twin lift stability
- Load Capacity 1000kg

PM500ELEC Electric Couch

PM500HYD Hydraulic Couch



DELIVERY
Delivery is approximately 3 to 4 weeks. Please contact Customer Services for more information.

1



2 YEAR WARRANTY



1 Colenso Examination Couches

The Colenso examination couch is exceptionally stable, durable and comfortable for the client. Optional drawer unit available.

Features:

- Multi-position self locking adjustable backrest
- Stylish 60mm diameter legs improves stability
- Flame retardant upholstery (BS5852)
- Paper roll holder included (Fits at head or foot end)
- British made
- CE marked

Dimensions: Height 79cm. Length 183cm. Width 60cm.

- 09 115 8112** Black
- 09 115 8120** Blue
- 09 115 8138** Grey
- 09 115 8146** Beige

Maximum user weight

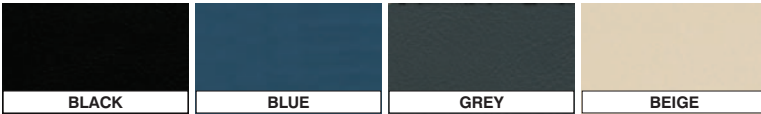

Colours are as accurate as the printing process will allow.

2 Height Adjustable Portable Cable Couch

A lightweight, portable couch with a variable height and adjustable backrest. Constructed from aluminium with soft foam padded upholstery and a hinged breathing hole plug as standard. The couch has a cable design, which provides excellent stability. Height 72 to 80cm. Length 183cm. Width 61cm. Weight 15kg.

- AA9565B** Blue
- AA9565H** Beige
- AA9565K** Dark Blue
- AA9565G** Black
- AA9543C** Carry Case

Maximum user weight



2



3 Hi-Value Portable Couch

This portable couch has fire retardant upholstery mounted on an extremely rigid and sturdy yet lightweight aluminium frame. Standard features include multi-position raising backrest, breathing hole and a protective carrying bag. Height 76cm. Length 183cm. When folded: Height 17cm. Length 91cm. Width 76cm.

		Width	Weight
AA9543B	Blue	61cm	15kg
AA9543H	Beige	61cm	15kg
AA9543K	Dark Blue	61cm	15kg
AA9543G	Black	61cm	15kg
AA9543WB	Blue	69cm	19kg
AA9543WH	Beige	69cm	19kg
AA9543WK	Dark Blue	69cm	19kg
AA9543WG	Black	69cm	19kg
AA9543C	Carry Case		

Maximum user weight



3



DELIVERY
Delivery is approximately 3 to 4 weeks. Please contact Customer Services for more information.

MADE TO ORDER
This item is made to order and, therefore, is not refundable.

1 Deluxe Professional Grade Portable Couch

We are proud to launch our sturdiest ever portable couch. Designed for the professional therapist, this robust couch is built to the most exacting of specifications. With its four leg cable suspension system providing greater support and incorporating a thick, wipe clean fabric, this unique portable couch can withstand even the most rigorous of sports massages.

With the therapist in mind, this couch has the finesse of curved end panels to allow easy access around it. It also gives the therapist far greater flexibility, by offering a 10-position backrest and removable breathing hole.

Dimensions: 183cm x 61cm

Height adjusts: 66cm to 81cm

Weight: 15kg

TAB038 Blue

TAB038W Ivory

Optional Extras

TAB024A Trolley Bag

Maximum user weight



1



NEW

1 Affinity Portable Flexible Table

The portable/flexible massage table can be used for a wide variety of treatments. It features a 75° lifting head section, sturdy construction and removable breathing hole have quickly established this table as one of the best in the market. Specially shaped end plates allow excellent access at either end. Comfortable "Therafoam" cushioning system gives support and comfort even during long treatments. Height adjustable from 63-81cm, can be adjusted using the "Easi-turn" knobs which are easy to grip.

Features:

- 10 position lifting back rest
- Rapid set up reducing delay between appointments or allowing your treatment room to be used for other purposes
- Durable double backed PVC upholstery resisting nicks and tears for years of continued use
- Triple-ply "Therafoam" 50mm rated semi-firm for sports and remedial massage
- Foam-filled high strength luxury carry handles, for improved portability
- Free two year warranty on this item covering, frame, base and factory faults on the vinyl
- 450lb impact strength (32st dropped from 7"!) plus high strength when force is applied across the table (lateral movement)
- Carry case included as standard
- Available in biscuit or grey

Dimensions: Length 185cm. Width 68cm. Weight 16.8kg.

09 142 2997 Biscuit

09 142 3003 Grey

09 142 7665 Couch Cradle and Arm Support

Maximum user weight

205 kg **32¹/₂ st**



1



COUCH CRADLE AND ARM SUPPORT

2 Wooden Adjustable Portable Couch

- Exceptional height variation 57-90cm
- Wheeled carry case
- Ideal for heavy massage
- Hand crafted in hardwood
- Length 183cm, Width 69cm, Height 57-90cm
- Weight 18kg

TAB012W

Maximum user weight

181 kg **28¹/₂ st**

2



DELIVERY

Delivery is approximately 1 week. Please contact Customer Services for more information.

1 Affinity Marlin Portable Table

A truly portable couch at only 14.5kgs. With a one touch height adjustment feature, this aluminium table is designed to be put up quickly, used and taken to the next appointment, with the minimum of strain and difficulty for the therapist. It is exceptionally rigid, can take large clients without fuss, and its lifting head section enables the most beneficial position for the client and therapist. Height adjustable from 58-81cm, precise telescopic legs allow the height to be adjusted rapidly whilst still retaining the stability required for high impact treatments.

Features:

- 10 position lifting back rest
- Rapid set up reducing delay between appointments
- Durable double backed PVC upholstery resisting nicks and tears for years of continued use
- Triple-ply "Therafoam" 50mm rated semi-firm for sports and remedial massage
- Foam-filled high strength luxury carry handles
- 450lb impact strength (32st dropped from 7") plus high strength when force is applied across the table (lateral movement)
- Carry case included as standard
- Dimensions: Length 185cm, width 63cm
- 2 year warranty

S0086

220000 Couch cradle and arm support

Maximum user weight



1



COUCH CRADLE AND ARM SUPPORT



10 POSITION LIFTING BACK REST



ROUNDED CORNERS

2 Affinity Athlete Portable Table

The brand new Affinity Athlete is a premium massage table with an "hour-glass" shape allowing superior comfort for the client and unrivalled access to the lumbar area for the therapist. The ergonomic shape, shaped end panels and lightweight design mean easier transportation and superior body positioning for the therapist. Lightweight and strong, weighing only 14.5kg. Ideal for a range of treatments such as sport massage, deep tissue and osteopathy. The lifting backrest offers the best of both worlds ideal for seated treatments, consultations or strapping. Height adjustable from 58-81cm, precise telescopic legs allow the height to be adjusted rapidly whilst still retaining the stability required for high impact treatments.

Features:

- 10 position lifting back rest
- Rapid set up reducing delay between appointments
- Durable double backed PVC upholstery resisting nicks and tears for years of continued use
- Sculpted centre section: hour glass construction permits the therapist perfect access to the lumbar area. The wider areas maintain comfort for the client
- Face cradle and armsling, lengthens the table by 30.5cm and enhances client comfort compared to a breathe hole
- Triple-ply "Therafoam" 50mm rated semi-firm for sports and remedial massage
- Foam-filled high strength luxury carry handles
- 450lb impact strength (32st dropped from 7") plus high strength when force is applied across the table (lateral movement)
- Carry case included as standard
- Dimensions: Length 185cm, 54-68cm
- 2 year warranty

09 142 2989 Affinity Athlete Portable Table

09 142 7665 Couch cradle & arm support

Maximum user weight



2

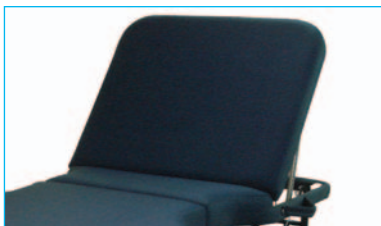

10 POSITION LIFTING BACK REST



ROUNDED CORNERS

DELIVERY
Delivery is approximately 1 week. Please contact Customer Services for more information.

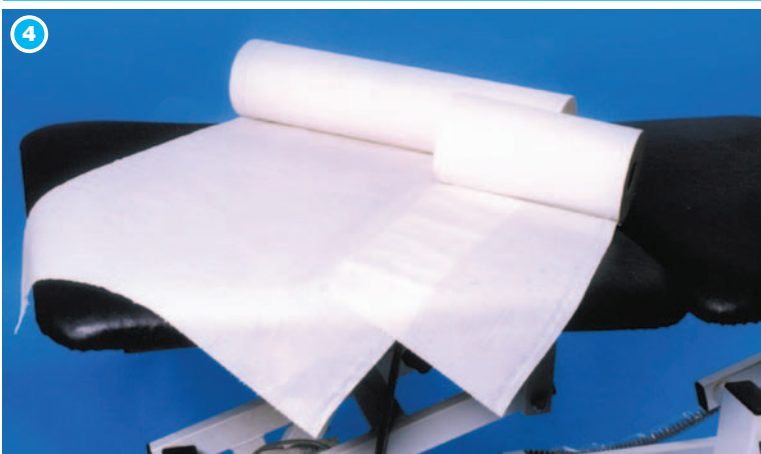
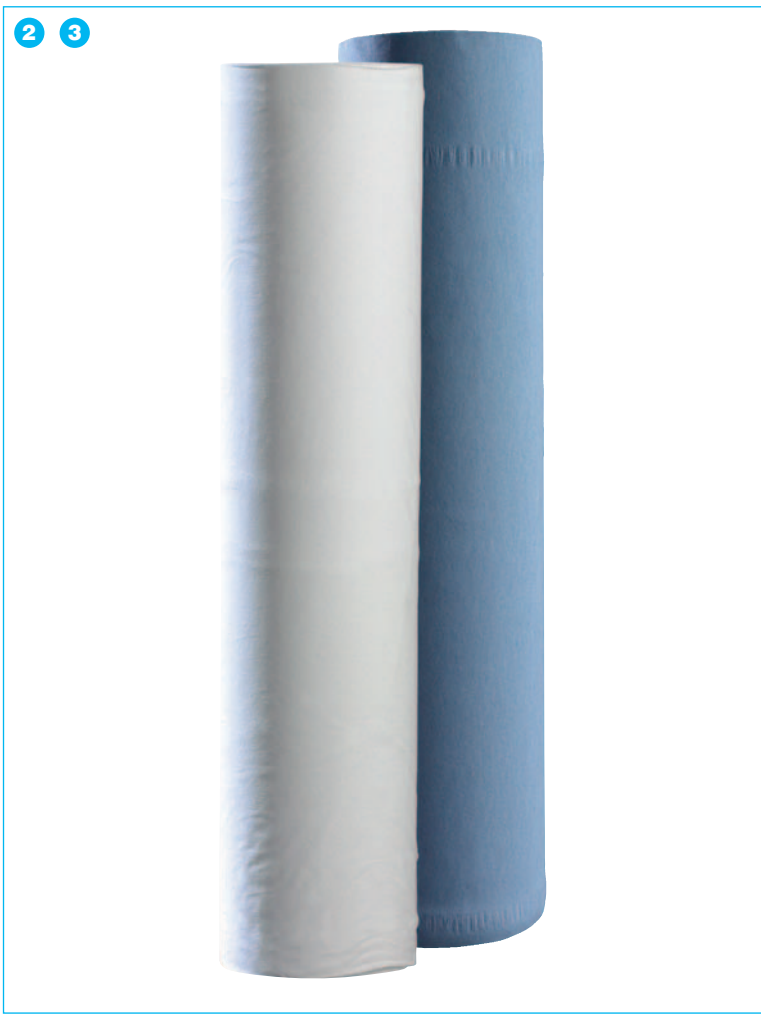

1 20" Plastic Backed White Couch Roll

The paper layer absorbs liquids, whilst the impermeable plastic layer prevents any liquids seeping through onto the couch or material below.

This specialist couch roll is ideally suited to procedures or treatments where there is a risk of fluids penetrating regular paper-only couch roll, contaminating the surface below. This couch roll allows absorption but not penetration.

- 20" wide rolls
- 1 ply paper, 1 ply polythene
- Easy tear perforations
- White in colour
- 50 metres per roll
- 6 rolls per case, Rolls are 20" - NOT SOLD SEPARATELY

COU-90 Plastic Backed Rolls

2 20" Progena Couch Roll

- 9 rolls per case
- 40m per roll
- 20" wide rolls
- Premium quality 2 ply tissue
- Bright white or blue in colour
- Easy tear perfect perforations
- 100% sourced from managed forests

COU-85W White

COU-85B Blue

COU-85BC White - Case of 9

COU-85WC Blue - Case of 9

3 20" Luxury Embossed Couch Roll

- 9 rolls per case
- 32m per roll
- 20" wide rolls
- Bright white in colour
- Premium quality 2 ply tissue
- Easy tear perfect perforations
- 100% pure paper sourced from managed forests

COU-80 White

COU-80C White - Case of 9

4 Couch Paper Rolls

09 118 0264 25cm (10")

09 118 1429 case of 24

09 118 0272 50cm (20")

09 118 1437 case of 12

1 10" Wiper Roll

- 18 rolls per case
- 40m per roll
- 10" wide rolls
- Bright white or blue in colour
- Premium quality 2 ply tissue
- Easy tear perfect perforations
- 100% pure paper sourced from managed forests

COU-95WC White Rolls 18 per case

COU-95BC Blue Rolls 18 per case

2 10" Luxury Embossed Wiper Roll

- 18 rolls per case
- 32m per roll
- 10" wide rolls
- Bright white in colour
- Premium quality 2 ply tissue
- Easy tear perfect perforations
- 100% pure paper sourced from managed forests

COU-100 White 1-8 Rolls

COU-100C White 1 Case

3 Physio-Med Couch Rolls

- Available on 10" or 20" widths
- 12 rolls per case
- 40m per roll
- 100 sheets per roll
- White and Blue available

	Width	Colour
MEF085	10"	White
MEF085B	10"	Blue
MEF080	20"	White
MEF080B	20"	Blue



DELIVERY

Delivery is approximately 3 to 4 weeks. Please contact Customer Services for more information.

1



1 Terry Towelling Couch Covers

The highest quality couch covers with breathing holes or plain. Check our options for different colours and with or without a breathing hole.

Without Breathing Hole

- TAB075** Flo White
- TAB085** Royal Blue
- TAB086** Navy Blue
- TAB060** Pale Blue

With Breathing Hole

- TAB055** Flo White
- TAB057** Royal Blue
- TAB058** Navy Blue
- TAB036** Pearl
- TAB045** Pale Blue

2 Couch Covers

A new range of top quality couch covers. These extra thickness covers have a gsm (grams per square metre) of 325. Made from 80% cotton & 20% polyester knit stretch terry towelling with elastic edging and two ties. Available in four different colours to fit standard 2 and 3 section couches.

Without Breathing Hole

- 220626** White
- 220627** Royal Navy
- 220629** Powder Blue
- 220630** Burgundy

With Breathing Hole

- S1989** White
- S1988** Royal Navy
- S1991** Powder Blue
- S1990** Burgundy

3 Face Savers

Many patients find lying in the prone position both uncomfortable and claustrophobic. Face Savers are soft and comfortable, and when placed over the breathing hole, they allow the patient to lie with the forehead and cheeks on the saver and relax and breathe easily.

This compact product is manufactured from polyurethane foam and comes complete with looped fleece cover, removable for laundering. Additional covers available to match couch covers.

- 009690** Standard Foam
- 009570** Memory Foam
- 221404** Cover - Royal Navy
- 221405** Cover - Pure White
- 221406** Cover - Burgundy
- 221407** Cover - Powder Blue

2



3

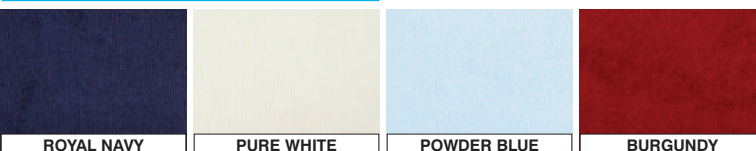

Colours are as accurate as the printing process will allow.

1 Affinity Body Bolster Set

The Affinity BodyBolster Set can enhance a wide variety of massage and physical therapies. Supporting the client at the clavicle, ribs, sternum and pelvis it relaxes the client, making the work of the therapist easier. It allows quicker and more effective treatment with reduced effort. The BodyBolster set can be placed on any massage table, or directly on the floor, and can be used by any client but has been shown to benefit pregnant, injured or larger clients. Highly portable and lightweight, it comes with its own shoulder carry case. The BodyBolster set comprises face, sternum, pelvic and split leg bolsters and carry case.

09 142 8028

2 Massage Cushion Set

The massage cushion set can be used on any couch to provide additional support during treatment. The set includes a face pad and three wedges that can be positioned where required. Two of the wedges can be zipped together to form a single unit.

A4411

3 Memory Foam Face Pad

Ultra comfortable memory foam face pad with 'cotton soft' removable cover.

- 18 x 16cm Hole 14 x 11cm

TAB05

4 Face Pad

Face pad to provide extra comfort and aid breathing when lying in a prone position on a couch. Made from covered foam, this simple addition can make treatments more relaxing.

A4414

5 Patient Footbath

An ideal way to wash your patient's feet before you start treatment. The footbath is on lockable wheels to secure the position and comes with disposable basin covers to reduce cross infection.

016429

Patient Footbath Disposable Footbath Covers

016430 15 covers

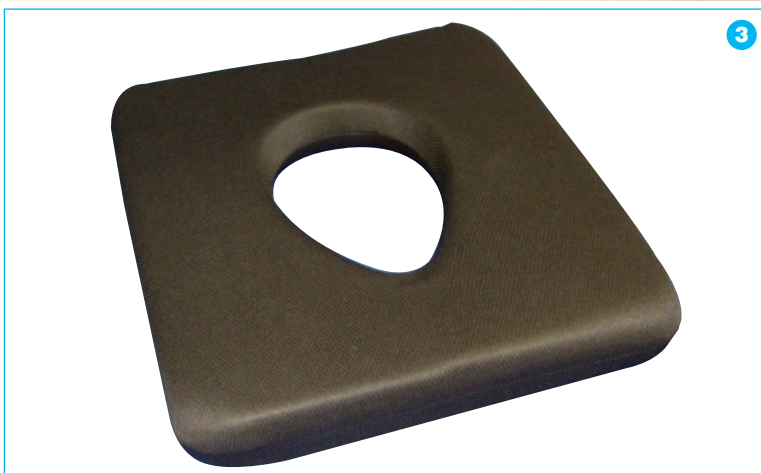



1

2 YEAR GUARANTEE

1 Paediatric Two Column Changing Table Homecraft

This height adjustable changing table is designed to assist with the moving and handling of children and adults while they are being changed. The height range provide safe transfer heights and a safe working height. The height adjustment is easily controlled using a simple battery powered rechargeable hand controller. It is available with or without castors. It is brightly coloured to aid compliance and the strong and robust design ensures a long life with minimal maintenance. Two year guarantee.

- Rechargeable Hand Controller
- Storage shelf

Width 70cm. Two Length options. Height adjustable from 520 to 103cm on standard versions and 62 to 113cm on mobile versions.

Standard without Castors

- 09 118 2781** Length 120cm
- 09 118 6923** Length 150cm

Mobile with Castors

- 09 120 6085** Length 120cm
- 09 120 6093** Length 150cm

Maximum user weight **180 kg** **28 1/4 st**  



2

2 YEAR GUARANTEE

2 Universal Changing Table Homecraft

This changing table has excellent manoeuvrability due to retractable wheels and can be fitted with cot sides for patient safety. It features a strong, robust design and a two-year guarantee.

- Hand switch control on electric model
- Retractable wheels
- 23cm clearance for mobile hoist

Length 182cm (71"). Width 70cm (27"). Height adjustment 50 - 92cm (19 - 36").

- AA9509H** Hydraulic
- AA9509E** Electric UK Plug
- 09 116 4250** Electric EU Plug
- 09 119 1782** Cot Sides

Maximum user weight **225 kg** **35 1/2 st** 



3

3 SKM Changing Table

This extremely versatile platform has a staggering height range from 35 to 108cm and can carry a load of up to 100kg. Its attractive non-clinical design ensures it never looks out of place, wherever it is used. Safety is paramount and padded safety rails at the side and a steel back panel ensure containment on all sides when the operator is in front of the table. Mains powered with remote control. Available as standard or folding to save space when not in use. The legs are not folding. Total distance from wall when folded 52cm (20"). Length 120cm (47"). Width 70cm (27"). Height adjustment 35 - 108cm (13 - 42"). Note: The SK Electronic Easychange is not intended for use in wet areas.

- AA95091** Folding

Maximum user weight **100 kg** **15 3/4 st** 

 **UK NEXT DAY DESPATCH**
Delivered from stock. Please contact Customer Services for more information.

 **DELIVERY**
Delivery is approximately 3 to 4 weeks. Please contact Customer Services for more information.

 **MADE TO ORDER**
This item is made to order and, therefore, is not refundable.

1 Paediatric Changing Table Homecraft

The paediatric table is brightly coloured making it fun for children and aiding compliance. It is strong and robust and has a two-year guarantee.

- Hand switch control on electric model
- Retractable wheels
- 16cm clearance for mobile hoist
- Padded cot sides as standard

Length 150cm (59"). Width 70cm (27"). Width including cotside 85cm (33"). Height adjustment 44 - 86cm (17 - 33"). Max overall length when lowered 182cm (71"). Recommend a manoeuvrability clearance of 160cm (63") is allowed.

- AA95111** Electric UK Plug
09 115 8104 Electric EU Plug
09 115 8096 Hydraulic

Maximum user weight **180 kg** **28 st**



2 YEAR GUARANTEE



2 Pressalit Nursing/Shower Bench

This height adjustable nursing bench is designed to help with the safe moving and handling of children and adults while they are being changed or showered. The bench is slightly curved making it extremely comfortable and safe. The height adjustable bench can be adjusted from a suitable transfer height (30cm) to a safe caring height (100cm) (note these heights are dependent upon fixing position). This movement is easily controlled by a simple, remote control hand unit. When the fixed height bench is mounted at the recommended height, the lying surface height is 86.5cm above the floor. The integrated gas cylinder also enables the bench to be folded easily against the wall when not in use to maximise floor space.

The nursing bench benefits from a water collection tray with an integrated water outlet that prevents water from splashing on carers or on the floor. The bench, end caps and safety rail are all covered with polyurethane foam so that there are no cold surfaces exposed. The bench also benefits from a manually adjustable back support at both ends for increased comfort for the user. The safety rail can be easily folded up or down using only one hand. Available in two adjustable height versions and two fixed height versions.

Supplied complete with safety rail	Total Length
09 117 4721 Adjustable Height Bench	143cm
09 117 4739 Adjustable Height Bench	193cm
09 117 4747 Fixed Height Bench	143cm
09 117 4754 Fixed Height Bench	193cm

Spares

- 09 117 4762** Safety Rail 163.5cm
09 117 4770 Safety Rail 120cm

Maximum user weight **200 kg** **31 1/4 st**

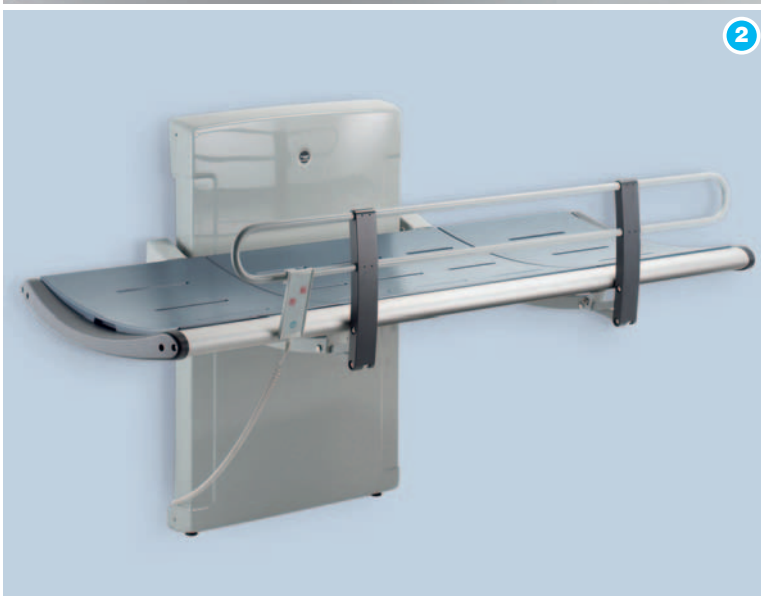

NDD UK NEXT DAY DESPATCH
 Delivered from stock. Please contact Customer Services for more information.

DELIVERY
 Delivery is approximately 4 weeks. Please contact Customer Services for more information.



1 Electric Adult Tilt Table Homecraft

An economical tilt table that includes some outstanding features. Manufactured to a very high standard, it represents exceptional value for money. Tilt tables are used extensively in functional rehabilitation where the requirement to stand or be upright is of paramount importance. Standing can improve quality of life, assist in the natural gravitational functions of the body, re-educate balance mechanisms affected by long periods of lying and give a degree of independence. The design of this tilt table also means that the footboard can be removed so it can be used as a plinth featuring a negative head section and breathing hole with plug. With an extremely smooth movement, this tilt table is designed to promote confidence in both the client and the therapist.

Features

- Smooth electric tilt operation
- 0 to 90° tilt adjustment
- Four large braking castors for safety and ease of movement
- Three straps for added client safety
- Side handles to promote client confidence
- Worktable as standard
- Flame retardant upholstery
- Steel frame with powder coated finish for strength and durability

Height 71cm. Length 183cm. Width 60cm.

AA95139BUK	Blue	UK Plug
AA95139HUK	Beige	UK Plug
AA95139KUK	Dark Blue	UK Plug
AA95139GUK	Black	UK Plug
AA95139BEX	Blue	EU Plug
AA95139HEX	Beige	EU Plug
AA95139KEX	Dark Blue	EU Plug
AA95139GEX	Black	EU Plug

Maximum user weight



2 Electric Paediatric Tilt Table Homecraft

This electric tilt table has been especially designed for children, catering for a number of treatment requirements to improve the quality of life for the smaller patient. Brightly coloured in blue and red vinyl to promote compliance, it also features an adjustable pommel and pelvic supports to improve confidence for both the child and the therapist.

Features

- Electric tilt operation
- 0 to 90° tilt adjustment
- Four large braking castors for safety and ease of movement
- Height adjustable footboard and pommel
- Adjustable pelvic supports
- Flame retardant, brightly coloured upholstery
- Steel frame with powder coated finish for strength and durability

Height 65cm. Length 137.5cm. Width 48cm.

AA95140UK	UK Plug
AA95140EX	EU Plug

Maximum user weight



DELIVERY
Delivery is approximately 4 to 6 weeks. Please contact Customer Services for more information.

MADE TO ORDER
These items are made to order and, therefore, are not refundable.

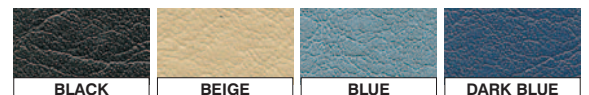

Colours are as accurate as the printing process will allow.

1 Akron Tilt Table

The Akron Tilt Table has numerous applications in both examination and treatment procedures. As a product it adds diagnostic value in vascular laboratories, for haemodynamic assessments; in general ultrasound departments, for positional scanning and in cardiac departments for 'tilt-testing'. Tilt tables are also used extensively in the area of functional rehabilitation for disabled people where the requirement to stand or be upright is of paramount importance, where it improves the 'quality of life', assists the natural gravitational functions of the body, re-educates the balance mechanisms affected by long periods of lying and gives a degree of independence. A quick release option is available to enable the lowering of the table from a tilted position to horizontal in an emergency situation such as a clinical need for the user or during a mains power failure.

Features

- Electric height and electric tilt
- Full 90° of tilt
- Adjustable angle foot board
- Lowers to wheelchair height
- Large braking castors
- Tilt angle indicator
- Choice of four upholstery colours (see below)

Height 46 to 84cm. Length 190cm. Width 64cm.

Accessories Included (Standard)

- Work table (adjustable angle and removable)
- Hand grips (removable)
- Three fixation belts (thoracic, pelvic and knee)

Accessories Included (Split Leg)

- Hand grips (removable)
- Three fixation belts (thoracic, pelvic and knee)
- Individual Knee Harness - Pair

Akron Tilt Table				
Colour	Standard UK Plug	EU Plug	Split Leg UK Plug	EU Plug
Blue	09 113 6894	09 113 6712	09 113 6829	09 113 6787
Beige	09 113 6910	09 113 6738	09 113 6845	09 113 6803
Dark Blue	09 113 6928	09 113 6746	09 113 6852	09 113 6795
Black	09 113 6902	09 113 6720	09 113 6837	09 113 6811

Maximum user weight

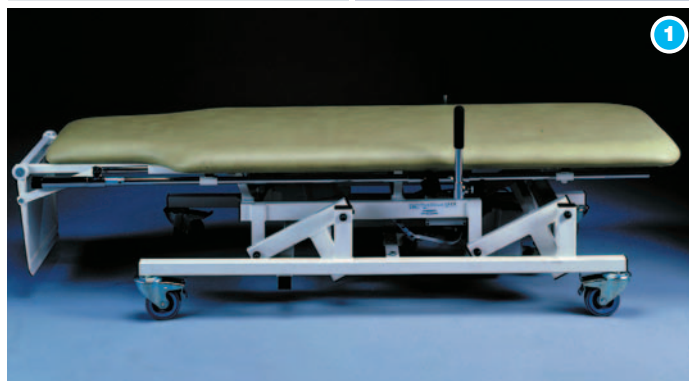

2 Accessories

A number of accessories are available that cater for users who require additional support during tilt table procedures. These accessories must be specified at the time of ordering.

- AA9528S** Replacement Fixation Belts - Set of 3
- AA9528F** Adjustable Height Child Footboard*
- AA9528K** Replacement Individual Knee Harness - Pair*
- AA9528P** Adjustable Height Pommel*
- AA9528B** Pelvic/Upper Body Supports - Pair
- AA9528H** Sculptured Head Cushion
- AA9528Q** Quick Release Option

*The split leg version must be ordered for the fixation of these accessories.



QUICK RELEASE OPTION



ADJUSTABLE HEIGHT FOOTBOARD



INDIVIDUAL KNEE HARNESSES

DELIVERY
Delivery is approximately 4 to 6 weeks. Please contact Customer Services for more information.

MADE TO ORDER
These items are made to order and, therefore, are not refundable.

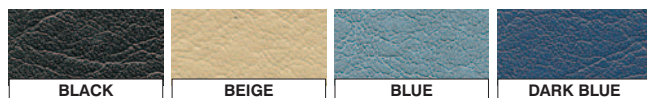

Colours are as accurate as the printing process will allow.



1 Pneumatic Wheelie Stool

A height adjustable wheelie stool with swivel castors for easy mobility when sitting. Made from high density thick foam with a wipe clean vinyl seat. Colours may vary. Seat height adjusts from 41 to 54cm. Seat diameter 46cm.

AA9524
Maximum user weight **117 kg** **18 st**

2 Standard Flat Top Stool

Height adjustable Flat Top Stool in blue. 54cm base. 34cm top. 54-68cm lift
TAB420

3 Gas-Lift Stools

This high quality gas-lift stool features a deluxe comfortable padded seat with anti-bacterial upholstery. Available in a choice of colours. The five castors offer stability and ease of manoeuvrability. The seat is adjustable from 42 to 58cm.

- 09 115 7320** Black
- 09 115 7338** Parchment
- 09 115 7353** Jade
- 09 115 7361** Sky Blue
- 09 115 7346** Grey

4 Multi-Purpose Stool

This height adjustable stool benefits from a shaped cushion for better posture and circulation. Aluminium five star base and a single lever height adjustment. Wipe clean vinyl. Seat height 43 to 54cm. Weight 5kg. Base diameter 60cm
AA95008

5 Buddi Stool

A height and angle adjustable stool for therapists, designed to take the strain out of therapy time. Assists physiotherapists when working at a low level with disabled children. This enables the therapist to interact at eye level with the children they are attending, thus reducing the need for bending. The Buddi can be tilted to benefit posture and is height adjustable by means of a lever controlled gas lift. The Buddi has a five point base with castors to aid manoeuvrability. An upholstered sleeve-on pad is also included for extra comfort. Seat height with seat horizontal 40 to 50cm or with seat angled forward 37 to 47cm. Seat width 37cm. Weight 6.9kg.
AA9578

6 Posture Stool

The ergonomically designed posture stool helps to reduce the discomfort of sitting for long periods and improves seated posture. Exceptional value for money, this high quality stool is fully height adjustable and the seat has a tilt facility for added versatility. It is available with or without a backrest, in a range of colours to suit any clinic. Five-year guarantee. Height can be adjusted from 52 to 71cm.

	Colour
AA95061H	Without Backrest Sand
AA95061B	Without Backrest Space Blue
AA95061K	Without Backrest Imperial Blue
AA95061G	Without Backrest Forest
AA95062H	With Backrest Sand
AA95062B	With Backrest Space Blue
AA95062K	With Backrest Imperial Blue
AA95062G	With Backrest Forest



DELIVERY
Delivery is approximately 6 weeks.
Please contact Customer Services for more information.

MADE TO ORDER
This item is made to order and, therefore, is not refundable.

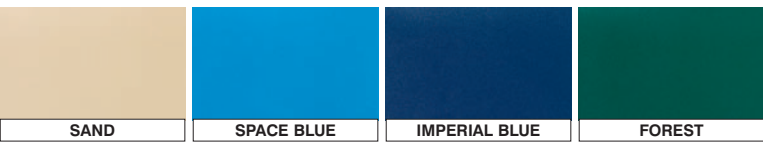

Colours are as accurate as the printing process will allow.

1 Gas-Lift Chairs

A comfortable therapy chair with a thick padded seat and back covered in durable wipe clean upholstery. The five-point base with castors aids manoeuvrability. Gas-lift, seat height is adjustable from 42 to 57cm.

AA95070	Without Arms	Black
AA95071	Without Arms	Parchment
AA95072	Without Arms	Jade
AA95073	Without Arms	Sky Blue
AA95074	Without Arms	Grey
AA95075	With Arms	Black
AA95076	With Arms	Parchment
AA95077	With Arms	Jade
AA95078	With Arms	Sky Blue
AA95079	With Arms	Nimes Grey



2 Advance Chair

A comfortable height and tilt adjustable chair, with a contoured seat, and lumbar support backrest to encourage correct posture. Height Adjustment 500 to 630mm.

09 118 8614	Sand
09 131 6140	Space Blue
09 131 6157	Imperial Blue
09 131 6165	Forest



3 Five Star Chair

A comfortable height and tilt adjustable chair, with a shaped and contoured seat, and lumbar support backrest to encourage correct posture. Height Adjustment 510 to 710mm.

09 118 8663	Sand
09 131 6116	Space Blue
09 131 6124	Imperial Blue
09 131 6132	Forest



4 Gemini Chair Standard

A comfortable height adjustable chair, with lumbar support backrest. Aluminium base with twin wheel castors. Chassis and metalwork finished in RAL 9002 cream.

Height Adjustment 480 to 610mm.

09 118 8697	Sand
09 131 6082	Space Blue
09 131 6090	Imperial Blue
09 131 6108	Forest



5 Gemini Stool with Swing Around Support

A comfortable height adjustable stool with a swing around support. Aluminium base with twin wheel castors. Chassis and metalwork finished in cream. Height Adjustment 550 to 730mm.

09 118 8671	Sand
09 131 6058	Space Blue
09 131 6066	Imperial Blue
09 131 6074	Forest



DELIVERY
Delivery is approximately 2 or 6 weeks.
Please contact Customer Services for more information.

MADE TO ORDER
This item is made to order and, therefore, is not refundable.

Colours are as accurate as the printing process will allow.



1 Saddle Stool with Tilting Backrest

Height adjustable stool. Comes with tilt adjustable backrest. 54cm base. 61-79cm lift.

TAB465 **A** Ivory Stool with tilting backrest

TAB430 **B** Stool with tilting backrest

2 Saddle Stool

Treatment saddle stool, adjustable height and tilt in Ivory. 64cm base. 62-81cm lift.

TAB460 **A** Ivory Saddle Stool

TAB425 **B** Blue Saddle Stool

3 Saddle Stool with Backrest

Height adjustable Stool. Comes with removable backrest. 54cm base. 61-79cm lift.

TAB435 Blue Stool with removable backrest

4 Saddle Stool

A cost effective height adjustable saddle stool. Shaped to encourage better posture and circulation, when sitting for long periods of time. Wipe clean vinyl. Height adjustment: 560 to 740mm. Base diameter 23½".

09 118 5891

5 Affinity Saddle Stool

Offers the therapist a much improved seated posture thereby minimising workplace injury. Seat size 40 x 36cm. Foam padding 7cm. Height range 50 to 67.5cm. Available in three colours.

09 142 8721 Navy Blue

09 142 8739 Biscuit

09 142 8747 Black



1 Adjustable Therapy Benches Homecraft

These Adjustable Therapy Benches are ideal for use by therapists or parents when working with children who do not need back support but need a seat that can be adjusted so that their feet rest on the floor. The height is easy to adjust and the seat can be tilted, which places more weight on the child's feet and aids postural control. Available in two sizes.

	Width	Length	Height
09 120 7232 Small	27cm	66cm	18-28cm
09 120 7240 Large	36cm	80cm	27-43cm

Maximum user weight **100 kg** **15³/₄ st**



2 Mobile Therapy Stool Homecraft

This Therapy Stool is designed for use by therapists, teachers or parents. The stool has a padded seat with a colourful vinyl covering. The height is adjustable from 34-46cm (13-18") and the stool has lockable castors for added security. Measures 45 x 37cm (17³/₄ x 14¹/₂")

09 120 6887

Maximum user weight **100 kg** **15³/₄ st**



3 Therapy Benches

These therapy benches have adjustable height and are designed to angle along or across the bench surface. They are available in three sizes and two widths. The ends have a side slot for easy safe and positive adjustment.

Short	Height	Length	Width
AA75315N	195-295mm	610mm	250mm
AA75315W	195-295mm	610mm	300mm
Medium			
AA75316N	280-455mm	820mm	300mm
AA75316W	280-455mm	820mm	380mm
High			
AA75317N	415-705mm	820mm	325mm
AA75317W	415-705mm	820mm	380mm



4 Wheely Therapy Stool

Designed for use by therapists, teachers and parents when working at floor level with children. They are adjustable in height to suit the individual and for stability. They should be used by sitting astride the narrower side.

Available with a Red seat or a Green seat. Height 340-460mm (13 to 18"). Length 450mm (17¹/₂"). Width 370mm (14¹/₂").

AA75312F Red
AA75312G Green



5 Therapy Stool and Bench

To be used by therapists, teachers and parents, these stools and benches are padded, mobile and height adjustable. Stools are available with or without lockable castors.

Therapy Stool

490 x 540mm, height adjustment 360-460mm.

AA75362 Swivel Castors
AA75363 Lockable Castors

Maximum user weight **80 kg** **12¹/₂ st**



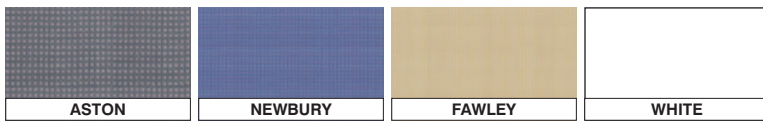

1 Doherty Panel Screen System

The Doherty Panel Screen system is designed to provide a modern alternative to traditional curtain screens. The system is available to fit to new Doherty epoxy coated or chrome screens and can also be fitted to existing screens to allow upgrading to a solid panel system.

- Easy to clean hygienic construction with high specification fire retardant plastic panels
- Simple to fit to new or existing Doherty screens
- Panels cover full frame of screen for complete privacy
- 4 panels per kit supplied with all required fastenings and fitting instructions
- Minimal assembly required

Dimensions: 168 x 224cm (fully extended) 168 x 61cm (closed)

SCR01/WHITE Frame Only (white epoxy)

SCR0/CHROME Frame Only (chrome)

SCRPK/WH Screen Kit, White panels

SCRPK/NEWBURY Screen Kit, Newbury panels

SCRPK/FAWLEY Screen Kit, Fawley panels

SCRPK/ASTON Screen Kit, Aston panels

SCR21 Plastic Screen Green

SCR22 Plastic Screen White

SCR23 Plastic Screen Blue

09 143 4232 Polyester Screen Cream

SCR25 Polyester Screen Blue

09 143 4240 Polyester Screen Green



2 Ward Screen

Metal framed, four fold screen fitted with easy glide castors. The curtains are supplied in white only, flame retardant P.V.C.

Dimensions: Length: 244cm, Height: 174cm

MEF075 Screen with curtains

MEF075A Curtains set of 4



3 Glass Mirrors Sammons Preston

For educational and therapy programmes where a reflective glass surface is preferred. Heavy plate glass with electroplated copper produces bright, distortion free images. Oak laminate frame provides an attractive appearance. The single section mirror and each panel of the three section mirror measure 69cm wide and 183cm high and may be locked into position. Both mirrors include brackets for mounting to a wall, and castors for a free standing unit.

5350 Single Section **SDD**

5351 Three Section



4 Posture Mirrors

Posture mirrors can be used for postural re-education and feedback for normal movement. Glass is bonded to laminate for added safety. Available on a hinged frame with castors for easy manoeuvrability and adjustability or as a wall mounted mirror. Panel size 120 x 36cm.

AA9569 Mobile

AA9569W Wall Mounted **SDD**



SDD UK SAME DAY DESPATCH
Please contact Customer Services for more information.

DELIVERY
Delivery is approximately 4 to 6 weeks.
Please contact Customer Services for more information.

1 Mobile Folding Screens

- Quality, hygienic easy to clean panels
- Flame retardant panels
- White epoxy coated frame for durability and ease of cleaning
- Minimal assembly required
- Available in a range of colours
- Available in three, four or five panels
- 2 year guarantee
- Dimensions:
Four section: Length 250cm. Width 48cm. Height 172cm.
Five section: Length 312cm. Width 48cm. Height 172cm.

3 Panel

- SUN-MFS3W** White
- SUN-MFS3PB** Patchwork Blue
- 09 142 8697** Sky Blue
- SUN-MFS3BUB** Bubbles
- SUN-MFSSIL** Silver
- SUN-MFS3BEI** Beige
- 09 142 8705** Wave
- 09 142 8689** Mr Men

4 Panel

- AA95034W** White
- AA95034B** Patchwork Blue
- 09 132 2510** Sky Blue
- AA95034U** Bubbles
- SUN-MFS4SIL** Silver
- SUN-MFS4BEI** Beige
- 09 132 2528** Wave
- 09 132 2502** Mr Men

5 Panel

- AA95035W** White
- AA95035B** Patchwork Blue
- 09 132 2544** Sky Blue
- AA95035U** Bubbles
- SUN-MFS5SIL** Silver
- SUN-MFS5BEI** Beige
- 09 132 2551** Wave
- 09 132 2536** Mr Men

**2 YEAR
GUARANTEE**



WHITE

sunflower
MEDICAL FURNITURE

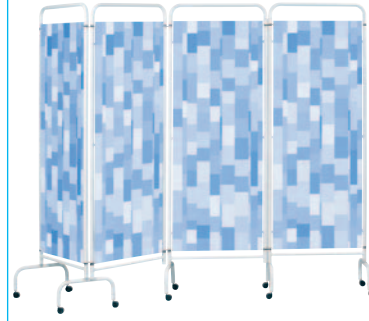

PATCHWORK BLUE



SKY BLUE



BUBBLES



SILVER



BEIGE

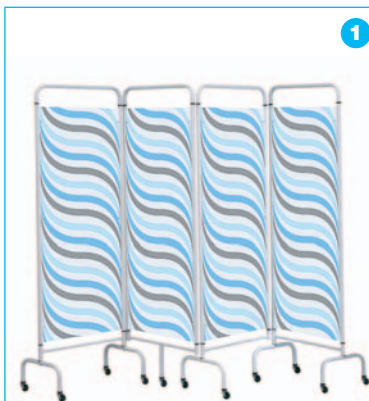

WAVE



MISTER MEN



DELIVERY
Delivery is approximately 2 weeks.
Please contact Customer Services for more information.

1 A



1 B



1 C



1 D



2



WHITE

2



CHROME

1 Kendal Waste Bins

A high quality range of bins designed specifically to suit the requirements of the modern clinic, hospital, nursing and residential care home environment. Each bin comes complete with a range of features and is manufactured primarily from galvanised steel to exacting specifications in the UK.

Features

- Pull out handle to allow easy movement
- The bins are designed so that they are difficult to open, by hand, encouraging the user to use the foot-operated pedal; thus minimising the risk of cross contamination
- The silent closing feature means that the lid closes quietly and slowly. This minimises the aerosol effect that could cause the spread of bacteria when a traditional bin lid closes
- Each bin is fitted with a specially designed wide pedal, which allows the sack holder to be approached from both the front and sides
- Wherever possible sharp edges have been removed and replaced with rounded corners
- Rubber Feet are fitted to stop the bin marking the floor and leaving unsightly rust marks
- The Air Gap allows the free movement of air beneath the bins stopping the build up of stagnant air that encourage the growth of bacteria
- Each bin comes with a comprehensive two-year warranty
- All the bins are fully fire retardant to HTM 83
- All bins come with a choice of lid colour, white for domestic waste and yellow for clinical waste

Doherty Waste Bins

	20ltr Small	50ltr Medium	70ltr Large
Height	570mm	792mm	805mm
Width	210mm	404mm	395mm
Depth	278mm	390mm	337mm
Overall Depth	340mm	420mm	430mm
Fire Retardancy	HTM 83	HTM 83	HTM 83

A 20ltr Small Waste Bin

09 117 1057 Solid Body/Domestic Waste

09 117 1065 Solid Body/Clinical Waste

B 50ltr Medium Waste Bin with Solid Body

09 117 1073 Solid Body/Domestic Waste

09 117 1081 Solid Body/Clinical Waste

C 50ltr Medium Waste Bin with Removable Body

With the added benefit of a removable body allowing for easy cleaning and sterilisation.

09 117 1099 Removable Body/Domestic Waste

09 117 1107 Removable Body/Clinical Waste

D 70ltr Large Waste Bin with Opening Door

Comes with a front opening door to allow easy removal of the sack and at the same time allows better access for cleaning the inside of the bin.

09 117 1115 Front Opening/Domestic Waste

09 117 1123 Front Opening/Clinical Waste



2 Pedal Bin

Ideal for helping to keep your practice in pristine condition.

004254 Chrome

004255 White



DELIVERY

Delivery is approximately 2 weeks.

Please contact Customer Services for more information.

Clinic Trolleys

These functional clinic trolleys feature sturdy, powder coated steel frames and four castors for easy manoeuvrability. Available in a variety of designs to provide the ideal trolley for any clinic environment.

1 Basket Trolley

Height 71.5cm. Width 60cm. Depth 41cm.
TRL026

2 Drawer Front Trolley

Height 71.5cm. Width 60cm. Depth 41cm.
TRL050

3 Drawer and Shelf Trolley

Height 71cm. Width 45.5cm. Depth 40.5cm.
09 143 0370

4 3 Tier Trolley

Height 78cm. Width 48cm. Depth 43cm.
09 143 0388



1



2



3



4



1 Gym/Equipment Trolley

A durable and practical storage trolley for large or awkward equipment. Made from epoxy coated steel with castors for easy manoeuvrability. Length 127cm. Width 66cm. Height 106cm.

AA9516



2 Multi-Cart Electrotherapy Trolley

This new design workstation is ideal for the majority of electrotherapy products and is fitted with large easy glide castors. It is ideal for both departments and clinics, fitted with 2 cable tidys and ultrasound gel holder. Height 84.5cm. Width 48cm. Depth 43cm.

TRL110

3 Thera-Son 2 Trolley

This sturdy trolley has been designed specifically for the Thera-Son 2 Ultrasound machine. Made from powder coated steel, it has two shelves providing plenty of storage for accessories, a cable cleat to prevent trailing wires and four castors for easy manoeuvrability. Height 69cm. Width 30cm. Depth 43cm.

ULS455



4 Caravel Dressing Trolley

A stylish and immensely practical dressing trolley of Italian design. In a white ABS plastic, the whole cabinet is a honeycomb of 10 useful storage compartments. The format of the three-tier trolley can be arranged to suit your needs.

004268



5 Mayo Stainless Steel Table

The Mayo table is a stainless steel, height adjustable table featuring a lipped tray to stop instruments rolling off, mounted on a single strut and a sturdy base with four castors. Use when carrying out surgical procedures.

007733

Spare Tray

007734



DELIVERY
Delivery is approximately 2 weeks. Please contact Customer Services for more information.

INFORMATION
The Thera-Son 2 Ultrasound can be found on pages 508 to 509.

1 Economy Trolley

This trolley features three 40 x 50cm shelves, all with a lip to prevent items from falling off. It has a hardwearing white finish and two of the castors are braked. Height 69cm.

AA95088



2 Stainless Steel Trolleys

These stainless steel utility trolleys are constructed from heavy duty, polished stainless steel. All shelves feature thick, 22 gauge steel shelves with double thick 16 gauge legs. 360° rotating castors are standard on all models. Holds up to 135kg.

Three-Shelf Trolley

554071 **A** Width 35.5cm. Depth 35.5cm.
Height 76.2cm.

Three-Shelf Trolley with Drawer

554072 **B** Width 53.3cm. Depth 40.6cm.
Height 76.2cm.

Three-Shelf Trolley with Handle

554073 **C** Width 61cm. Depth 40.6cm.
Height 81.3cm.

Three-Shelf Trolley with Locking Cabinet

554074 **D** Width 53.3cm. Depth 40.6cm.
Height 76.2cm



1



2

SDD UK SAME DAY DESPATCH
Please contact Customer Services for more information.

1



2



1 Economy Multi-Purpose Trolley

Features a removable clear tray with new tilting and locking runner system incorporating a label and cover and an adjustable shelf with two height settings. The white epoxy coated frame offers durability and ease of cleaning. Twin wheel castors aid movement. Width 56cm. Depth 52cm. Height 101cm.

AA9500E



2 Lockable Cabinets

Lockable cabinets conform to both the Misuse of Drugs (Safe Custody Regulation) 1973 and exceed British Standard BS 2881:1989 Security Level 1. The locking mechanism complies with BS 3621:1998 so keys cannot be removed if left open and it has more than 1000 combinations. They are constructed from 16 gauge steel with hardened hinges for security.

	Height	Width	Depth
09 115 7270	60cm	30cm	30cm
09 115 7288	60cm	50cm	30cm
09 115 7296	85cm	60cm	30cm
09 115 7304	60cm	80cm	30cm
09 115 7312	85cm	100cm	30cm

3



4



3 Dressing Trolley

This durable trolley is designed for everyday use. Made from strong epoxy coated steel with glass effect safety shelves that do not shatter like normal glass. The top tray has a unique lift-off design with integral handles. Supplied fully assembled. Two year warranty. Width 46cm. Depth 52cm. Height 86cm.

AA9500D3	3 Shelves
AA9500D2	2 Shelves

4 Surgical Trolley

Similar to the Dressing Trolley but with a stainless steel frame and shelves. Two year warranty. Width 46cm. Depth 52cm. Height 86cm.

AA9500S3	3 Shelves
AA9500S2	2 Shelves

5 Vista Multi-Purpose Trolley Accessories

A range of accessories for use exclusively with the Vista Multi-Purpose Trolleys featured opposite.

09 115 7221	A	Locking door for Vista 50 (6 trays)
09 115 7239		Locking door for Vista 50 (4 shallow, 1 deep)
09 115 7262		Locking door for Vista 30
09 115 7247		Locking door for Vista 20 (4 trays)
09 115 7254		Locking door for Vista 20 (2 shallow, 1 deep)
AA9500AB	B	Protective Buffers – Set of 4
AA9500AT	C	Tray Dividers for Vista shallow trays
AA9500AN	C	Tray Dividers for Vista deep trays

5



A

LOCKING DOOR



PROTECTIVE BUFFERS



TRAY DIVIDERS AND LABELS



DELIVERY

Delivery is approximately 2 weeks. Please contact Customer Services for more information.

Vista Multi-Purpose Trolley

A practical, durable range of trolleys supplied fully assembled with a two-year warranty. The removable trays, with new tilting and locking system, feature tray labels with covers as standard and are strong and easy to clean. The removable top shelf has an upstand on three sides to prevent items rolling off.

1 Vista 50

Vista 50 trolleys are available with a choice of either six single trays or four single trays and one deep tray making them versatile enough for any clinic. Width 56cm. Depth 52cm. Height 101cm.

	Colour	Trays
AA9500BC	Clear	4 Shallow, 1 Deep
AA9500BB	Blue	4 Shallow, 1 Deep
AA9500BG	Green	4 Shallow, 1 Deep
AA9500MC	Clear	6 Trays
AA9500MB	Blue	6 Trays
AA9500MG	Green	6 Trays

2 Vista 30

Vista 30 trolleys provide maximum storage in a compact design. They feature two shallow trays and two deep trays to suit a range of requirements. Width 39cm. Depth 52cm. Height 101cm.

	Colour	Trays
AA9500VC	Clear	
AA9500VB	Blue	
AA9500VG	Green	

3 Vista 20

Vista 20 trolleys have a lower height of just 78cm so that they fit under a work surface. Available with four trays or two trays with a deep tray. Width 56cm. Depth 52cm. Height 78cm.

	Colour	Trays
09 115 7171	Clear	4 Trays
09 115 7163	Blue	4 Trays
09 115 7189	Green	4 Trays
09 115 7205	Clear	2 Shallow, 1 Deep
09 115 7197	Blue	2 Shallow, 1 Deep
09 115 7213	Green	2 Shallow, 1 Deep



1



1 Saturn Unit

- A handcrafted unit, made with the finest materials
- The unique Corian® top ensures durability, and the ability to survive impacts, nicks and cuts. It has also been tested for resistance to stains and most acids
- Touch-latch drawer system for ease of operation and maintaining a hygienic environment; simply press the front and the drawer will glide out
- The unit's clean lines and sleek surfaces are not only stylish and contemporary in appearance, but also hardwearing and easy to maintain
- Very sturdy and comes with two lockable wheels
- A power cable and extra socket are supplied with the unit so that a drill and lamp can be powered from it

021986



2 Orion Unit

This is a solid, hand made cabinet ideal for those clinics with minimum storage space.

Features

- An optimum working level to reduce stress on the shoulder and back
- A pull up section to store 25cm couch roll
- 2 drawers to store dressings and blades
- A spacious drawer and cupboard compartment with more storage space for larger tools and care products
- Drawers held securely in place using magnetic strips
- Supplied with power cable so you can use a drill or lamp from the unit

Specification

- Height - 74cm
- Working height - 61cm
- Width - 60cm
- Depth - 39.5cm

016432



2



3 Mini Unit

This is a compact and neat unit that combines simplicity with quality and value for money.

Features

- Dual working levels increase working space
- 3 spacious draws to hold all podiatry equipment
- The draws are held securely in place using magnetic strips
- Supplied with a power cable so you can use a drill or lamp from the unit

Specification

- Height - 71cm
- Width - 50.5cm
- Depth - 41cm

016435

3



1 Adjustable Arm Table

An extremely comfortable, padded arm table, which tilts across a range of angles and rotates on a set of braked castors. Particularly useful during evaluation and rehabilitation. Length 60cm. Width 30cm. Height adjustable from 75cm to 115cm.

AA95401

2 Arm Table

A strongly constructed hardwood arm table made from beech with a Formica top. Length 61cm. Width 30cm. Height 71cm.

AA9520

3 Tilting Easel

Homecraft

This high quality tilting easel transforms a standard flat table into a tilting work surface. Can be used at any angle from horizontal to vertical. A lip at the bottom of the easel supports most activity boards and is removable to give a flat surface. Height 70cm. Length 70cm.

AA95402

4 Easel

Rolyan

For cognitive perceptual activities and range of motion exercises. Simplifies providing graded activities. Supports almost any activity board, such as puzzle boards and peg boards. Adjust shelf position to increase or decrease distance and angle of reach - shelf can be placed in any position on easel. Angle adjusts from 15° to 75° in increments of 10°. Slip resistant feet prevent easel from moving during activity. Easel folds for convenient storage. Plastic. Clean with a hard surface disinfectant. Measures 66cm high and 46cm wide with 4.4cm deep shelf.

AA405800





1 Activity Easywind™ Tilt Table

The Activity Easywind Tilt Table is an incredibly flexible, height adjustable table. It features a stainless steel basin that can be used for water play with a lockable timber infill for when the basin is not in use. The table has an adjustable angled surface with lip, and twin wheels that lock, ensuring that the table will not slip or pivot, leaving the user free to concentrate on the activity at hand. Available in standard or junior versions. Length 90cm. Width 60cm. Tilt 0° to 40°.

Height Adjustment

AA95094	Standard	60-86cm
AA95095	Junior	52-66cm



2 Ropox Ergotable

The Ergotable is a high quality, tilting table for rehabilitation settings. It is available with a choice of three tabletops to suit a range of applications. The tilting top is magnetic so paper can be held in place with magnets and magnetic stimuli can be used. Glide feet come as standard and there is the option of four hardwearing, lockable castors to aid ease of manoeuvrability. The top tilts in steps from horizontal to 54°. Full length 90cm. Length of tilting portion on split top tables 60cm. Width 60cm. Height adjustable from 56 to 84cm.

AA95107S	Standard Top
AA95107R	Right Hand Side Tilt
AA95107L	Left Hand Side Tilt
AA95108	Optional Castors



3 Variheight Table

The Variheight Table is manufactured to an optimum size for most environments, whether for single use or in a group. It is fully adjustable in height, enabling it to suit users of differing ages and circumstances. Low gearing and a detachable handle make height adjustment easy without removing any article from the tabletop. The table frame is made from heavy duty steel with a grey nylon epoxy coating. The tabletop is covered in a yellow melamine coating for added protection. The table is available in two models, the standard version or the lowline version. Both models are available with a plain flat surface or a tilt top version.

Dimensions

AA75313S	Standard Model
09 116 8137	Tilt Top Version
Tabletop size	914 x 762mm (36 x 30")
Height adjustment range	610-914mm (24-36")
AA75313L	Lowline Model
09 116 8145	Tilt Top Version
Tabletop size	914 x 762mm (36 x 30")
Height adjustment range	305-686mm (12-27")



STANDARD



TILT TOP

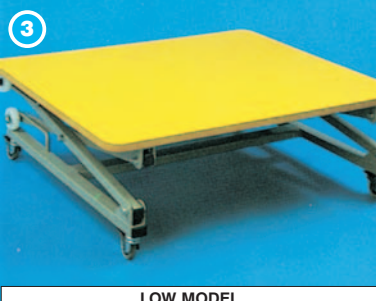

LOW MODEL

DELIVERY
Delivery is approximately 4 or 6 weeks. Please contact Customer Services for more information.

MADE TO ORDER
These items are made to order and, therefore, are not refundable.



1

1 Universal OT Table Homecraft

A work table for general occupational therapy use with an adjustable angle laminated work surface and a variable height.

- Hand switch control on electric model
- Large locking castors for mobility
- Optional knee block and standing harness
- Wheelchair cut-out

Dimensions: Height 50-92cm. Length 152cm. Width 70cm.

AA9508H OT Table - Hydraulic

AA9508E OT Table - Electric

AA9508 Padded Knee Block & Standing Harness



2 Treatment Table

This height adjustable treatment table features a scratch resistant grey laminate top with wheelchair cut-out. The top angles from 0° to 45° and the height of the table is adjustable from 74 to 112cm. Top measures 19 x 76 x 107cm. A 6.4mm raised metal edge round the table top prevents items from sliding off. Folds easily for storage when not in use. Weight 19kg. Washable.

A96160



2

UK SAME DAY DESPATCH
Delivered from stock. Please contact Customer Services for more information.



Vision is the new range of modern height adjustable Ropox tables. The Vision comprises of tables and accessories for a variety of activities. The tables are available in sizes to suit an individual or several people sharing. The beautiful and functional design was developed for people moving around with or without help. For children and adults alike who want the freedom to pursue their activities.

All Vision tables have soft round corners, and are provided with two inconspicuous castors at the back, making it easy to draw the table closer. Plain feet at the front give the tables extra stability.

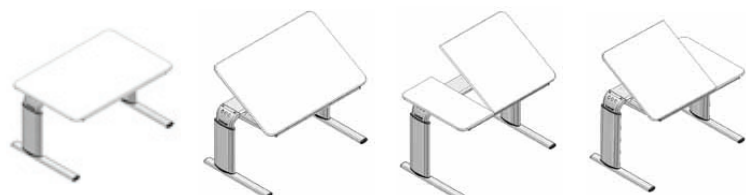

1 SECTION NO TILT **1 SECTION TILT** **2 SECTION RIGHT HAND TILT** **2 SECTION LEFT HAND TILT**

1 90 x 60 Vision Height Adjustable Table

- Width 90cm (35")
- Depth 60cm (23")
- Height Adjustment: 50 to 70cm (19 to 27") Low
60 to 90cm (23 to 35") High
- Electric or Manual Height Adjustment

1 90 x 60 VISION HEIGHT ADJUSTABLE TABLE - MANUAL

Height & Colour	No Tilt	1 Section Tilt	2 Section Tilt (RH)	2 Section Tilt (LH)
High White	09 120 3108	09 118 7863	09 118 7905	09 118 7954
High Light Grey	09 120 3116	09 118 7392	09 118 7418	09 118 7400
High Dark Grey	09 120 3124	09 118 7087	09 118 7129	09 118 7111
Low White	09 120 3090	09 118 7871	09 118 7913	09 118 7970
Low Light Grey	09 120 1870	09 118 7343	09 118 7046	09 118 7350
Low Dark Grey	09 120 3082	09 118 7020	09 118 7061	09 118 7657

1 90 x 60 VISION HEIGHT ADJUSTABLE TABLE - ELECTRIC

Height & Colour	No Tilt	1 Section Tilt	2 Section Tilt (RH)	2 Section Tilt (LH)
High White	09 120 3181	09 118 7848	09 118 7889	09 118 7921
High Light Grey	09 120 3173	09 118 7475	09 118 7517	09 118 7582
High Dark Grey	09 120 3165	09 118 7293	09 118 7327	09 118 7319
Low White	09 120 3157	09 118 7855	09 118 7897	09 118 7939
Low Light Grey	09 120 3140	09 118 7442	09 118 7509	09 118 7632
Low Dark Grey	09 120 3132	09 118 7145	09 118 7285	09 118 7277



2 120 x 60 Vision Height Adjustable Table

- Width 120cm (47")
- Depth 60cm (23")
- Height Adjustment: 50 to 70cm (19 to 27") Low
60 to 90cm (23 to 35") High
- Electric or Manual Height Adjustment

Accessories

3 MagRule

This magnetic rule helps keep reading material and work documents in place, even when the table is tilted.

09 118 8838

4 Arm Support

The arm support simply clips into place to provide extra support exactly where it is needed.

09 118 8846



MAGRULE



ARM SUPPORT



CORNER



CASTORS



HANDLE



ELECTRIC ADJUST

2 120 x 60 VISION HEIGHT ADJUSTABLE TABLE - MANUAL

Height & Colour	1 Section Tilt	2 Section Tilt (RH)	2 Section Tilt (LH)
High White	09 118 8267	09 118 8382	09 118 8531
High Light Grey	09 118 8242	09 118 8374	09 118 8523
High Dark Grey	09 118 8226	09 118 8366	09 118 8515
Low White	09 118 8291	09 118 8416	09 118 8564
Low Light Grey	09 118 8283	09 118 8408	09 118 8556
Low Dark Grey	09 118 8275	09 118 8390	09 118 8549

2 120 x 60 VISION HEIGHT ADJUSTABLE TABLE - ELECTRIC

Height & Colour	1 Section Tilt	2 Section Tilt (RH)	2 Section Tilt (LH)
High White	09 118 8150	09 118 8325	09 118 8465
High Light Grey	09 118 8135	09 118 8317	09 118 8457
High Dark Grey	09 118 8127	09 118 8309	09 118 8432
Low White	09 118 8218	09 118 8358	09 118 8507
Low Light Grey	09 118 8192	09 118 8341	09 118 8499
Low Dark Grey	09 118 8176	09 118 8333	09 118 8481



1 Easywind™ Group Table

This multi-purpose table is ideal for a range of activities including craftwork, dining, classroom activities and computer work and the special hardwearing laminate finish tabletop makes it easy to clean. It can be accessed by a number of seated users and is height adjustable via use of an easy-to-use wind-up crank handle. Locking wheels aid transport when the table is not in use. Length 160cm. Depth 85cm. Height 52 to 66cm.

AA95093



2 Dual Level Work Table

This innovative table is designed to enable the integration of wheelchair users with their peers. Because the table has two halves that are independently height adjustable, it is suitable to use with wheelchairs and standard chairs, and for children with bigger or smaller growth. Height 60 to 86cm. Length 120cm. Depth 38cm.

AA95096C



3 Midland™ Laminate Top Adjustable Work Table

Sammons
Preston

Height adjusts from 66 to 97cm with easy to turn crank handle. The crank handle stores conveniently under the table when not in use. A durable, easy to maintain 4cm thick Formica top resists dents and scratches. The smaller 71 x 152cm tabletop saves space, while the larger 122 x 168cm model accommodates six clients. Five-year warranty.

8858B Small
8859B Large



DELIVERY
Delivery is approximately 4 or 6 weeks. Please contact Customer Services for more information.

MADE TO ORDER
This item is made to order and, therefore, is not refundable.

1 Ropox Column Table

The Column Table from Ropox is a flexible group table solution offering various combinations. The table is available with a half-oval or square tabletop. The half-oval tabletop is 120 x 110cm with solid beech edges on three sides and the square tabletop is 110 x 110cm with solid beech edges on two sides. Both types are adjustable in height between 65 and 81cm by means of a crank handle. The tables can be combined so that several clients can sit at the same table but at various heights. Thus, individual height requirements are considered at the same table. One of the feet has a built in wheel for ease of transportation.

- AA95105** Square
- AA95106** Half-Oval



1

2 Economy Group Therapy Table

These value for money group therapy tables are available in three shapes to provide a variety of options. The 120cm diameter round table provides ample workspace for four clients in wheelchairs, while the 120 x 120cm square and pentagon tables can be tessellated to produce a much larger work space. A hydraulic mechanism easily raises the work surface from 61cm to 114cm.

- AA95051R** Round
- AA95051S** Square
- AA95051P** Pentagon



2

3 Ropox Multi Ergotable

A table designed to ensure proper working postures for both the user and the therapist, helping to obtain optimum rehabilitation results. The Multi Ergotable is a height-adjustable worktable with cut-outs at the front and back to support the body and forearms. The table is ideal for situations where the user and therapist need to be sitting close together opposite each other. Included are two 40cm diameter boomerangs, which can be easily fitted into the cut-outs to reduce their depth, and a moon-shape, which is used when only one cut-out is required. 30cm diameter boomerangs and additional moon-shapes are available. Length 90cm. Width 70cm. Height adjustable from 57 to 77cm.

- AA95109** Multi Ergotable
- AA95109B** 30cm Diameter Boomerang
- AA95109M** Moon-Shape



2

2



3



3

DELIVERY
Delivery is approximately 4 to 6 weeks. Please contact Customer Services for more information.

MADE TO ORDER
These items are made to order and, therefore, are not refundable.



1 Step Stool

A simple, sturdy stool consisting of a chrome plated steel frame with a non-slip rubber mat. Rubber ferrules provide good grip on slippery surfaces. Top area 28 x 36cm. Base area 30.5 x 41cm. Height 22.5cm.

AA6550

Maximum user weight

120 kg **18³/₄ st**

2 Step Stool with Handrail

A sturdy, stool with chrome plated steel frame. The stool has a non-slip textured mat on the surface. The rail, attached to one side of the step, helps to give the user extra confidence and stability. Rubber ferrules provide good grip on slippery surfaces. Top area 28 x 36cm. Base area 30.5 x 41cm. Height 22.5cm.

AA6551

Maximum user weight

120 kg **18³/₄ st**

3 Non-Slip Double Stepper

A new health and safety regulated non-slip double stepper. Manufactured from heavy duty flat sided oval finished steel in high gloss powder coating. Height 33cm. Width 45cm. Depth 37cm. Weight 7kg.

AA95011

Maximum user weight

120 kg **18³/₄ st**

4 Couch Step

This exceptionally stable, anti-tip couch step has a unique elliptical shape and a large, grooved anti-slip surface. Moulded plastic feet prevent movement. Height 16cm. Width 54cm. Depth 32cm.

AA95026

Maximum user weight

130 kg **20¹/₄ st**

5 Double Tier Couch Step

This couch step is the double tier version of the couch step above and features all the same high quality characteristics. Width 57cm. Depth 48cm. Height 40cm.

AA95027

Maximum user weight

130 kg **20¹/₄ st**

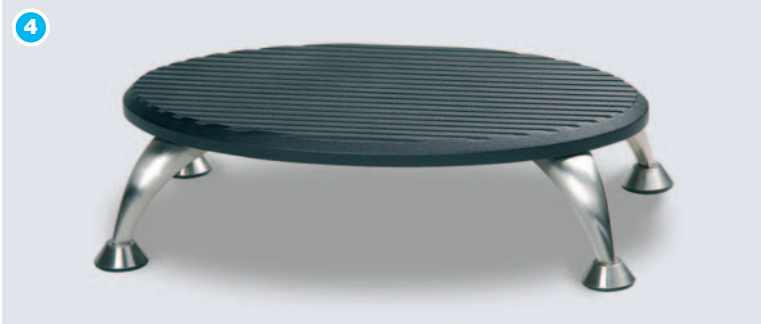

1 Nesting Step Stools

This set of wooden step stools is ideal for body mechanics and posture training when standing, to use at a desk or during seated mat activities. Non slip rubber surfaces prevents slipping. Nest for storage. Can be wiped clean. Set of four includes the following sizes:

Height	Width	Depth
20cm	50cm	45cm
15cm	45cm	40cm
10cm	40cm	35cm
5cm	35cm	30cm

AA9552

Maximum user weight

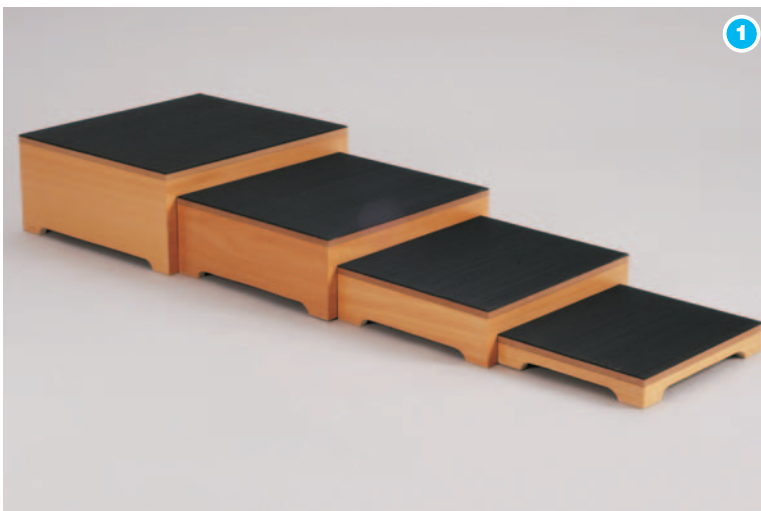

1

2 Ramp and Step Set

Great value for money, this ramp and step set can be used for a whole range of rehabilitation activities including ramp training, posture training and body mechanics. All surfaces are covered with non-slip rubber to provide safety and promote confidence. Can be wiped clean. Ramp platform measures 100 x 120cm. Ramp incline is 1:6. Three steps include the following sizes:

Height	Width	Depth
5cm	70cm	40cm
10cm	80cm	40cm
15cm	90cm	40cm
20cm	100cm	100cm

AA95085

Maximum user weight

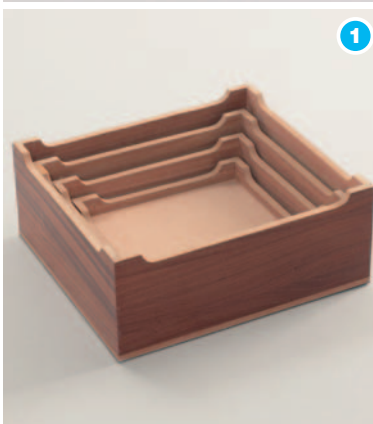

1



1

3 Curb and Ramp Training Set

Three steps with handles nest under the ramp platform when not in use. Anti-slip surface on ramp. Natural wood finish. Ramp platform measures 104 x 216cm. Ramp incline graduates from 1cm to 20cm high. Set of three includes the following sizes:

Height	Width	Depth
15cm	91cm	41cm
10cm	81cm	41cm
50cm	76cm	41cm

1590



2



3



DELIVERY

Delivery is approximately 4 to 6 weeks. Please contact Customer Services for more information.

1

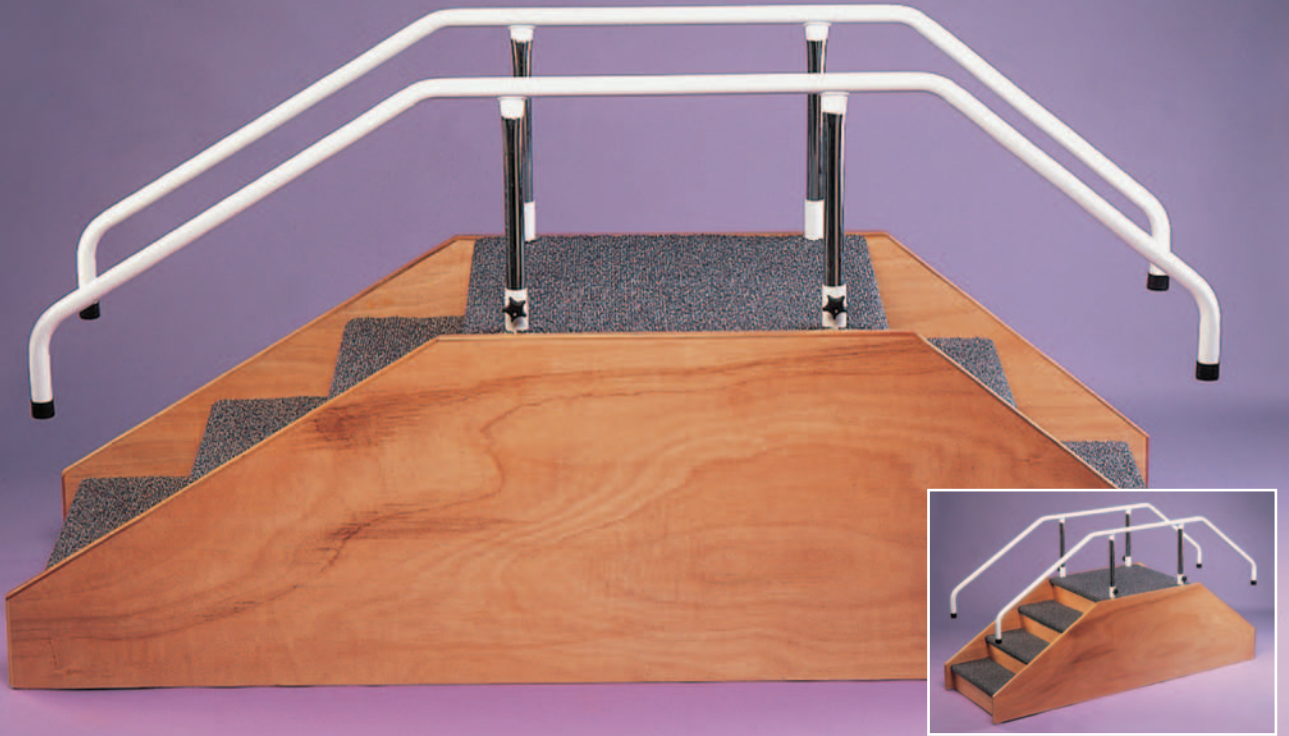

2



3



1 Conventional Steps

These high quality conventional steps feature three steps on one side and four on the other. On the side with three, the steps are 20cm deep and on the side with four, they are 15cm deep. The handrails are independently height adjustable from 40 to 90cm. Footprint: 193 x 65cm. Height 58cm.

AA9568

Maximum user weight



2 Alcove Steps

These ingenious steps are ideal for clinics where space is at a premium or where an alcove means space is wasted. Just 148cm wide, they feature four 15cm deep steps on one side and three 20cm steps on the other. Handrails are height adjustable from 40cm to 90cm.

AA95068 Footprint 140 x 150cm

Maximum user weight



3 Paediatric Steps

A scaled down version of the corner steps opposite, these steps are brightly coloured to brighten any paediatric clinic and aid compliance. On one side there are four steps with a depth of 11.5cm and on the other there are three steps with a depth of 15cm. The handrails adjust from 38cm to 75cm. Length 112cm. Width 94cm.

AA9567P

Maximum user weight



DELIVERY

Delivery is approximately 4 weeks. Please contact Customer Services for more information.



MADE TO ORDER

These items are made to order and, therefore, are not refundable.



INFORMATION

The maximum user weight refers to the steps only. The hand rails are not fully weight bearing and are for support only.



1 Corner Steps

Excellent quality hardwood steps, which are carpeted for safety and durability. These corner steps are in a set of four 15cm deep one side and three 20cm deep on the other side. The handrails are height adjustable from 40 to 90cm. Dimensions: Length 145cm. Width 120cm. Height 58cm.

AA9567

Maximum user weight **140 kg** **22 st**



2 Space Saving Steps

These stairs are made up of 2 sections and can be quickly adjusted so that they slot together, reducing the storage space required. Made from high quality hardwood with the 15cm deep steps covered in durable carpet. Handrails are height adjustable from 40 to 90cm.

Fully assembled: Length 140cm. Width 86cm. Height 60cm.

When compact: Length 87cm. Width 86cm. Height 60cm

AA9518

Maximum user weight **140 kg** **22 st**



SDD UK SAME DAY DESPATCH
Delivered from stock. Please contact Customer Services for more information.

INFORMATION
The maximum user weight refers to the steps only. The hand rails are not fully weight bearing and are for support only.

1



1 Closed-End Training Stairs

Oak and Steel construction. Steps descend from only one end. Steps made from Chequered (Pattern) Steel Plate. Features four 6" risers. Top platform measures 24" x 30".

Dimensions: 30" W x 54" L. Weight Capacity 450lbs

TS2

2 Standard Training Stairs

Powder coated steel hand rails and quality wooden base with antislip tread material on each step and platform for safety. Provides three 4" risers on one side, and two 6" risers on the other. When in use, the six-inch bus step creates a 12" riser on one side. Top platform measures 24" x 30" without the bus step.

Measures: 30" W x 54" L. Weight capacity 450lbs.

TS1

2



1 Rolyan Reach'N Range Overhead Pulley

Simple to use for re-building muscles and increasing range of motion. Dual overhead pulley offers extra stability and can be used with weights on one handle to counterbalance the strength of the opposite extremity. Weights (not included) can be added as strength improves. Overhead system positions the patient away from the door, allowing more free range-of-motion patterns, such as PNF patterns. Appropriate for home and clinic use.

A873620

2 Rolyan Reach'N Range Pulley

Easy-to-use pulley system for strengthening weakened shoulders and increasing range of motion. Features the innovative, easily adjusted ROM stop to control range-of-motion patterns. Easy length adjustability to fit patients quickly. Lightweight and compact for travelling convenience. Fits standard and thick doors.

A873623 **A** With Webbing Strap

A873624 **B** With Metal Bracket

3 Grahamizer I Multi-Use Exerciser

Ideal for post-mastectomy, clinic, and home exercise programmes. Exerciser combines many standard rehabilitation exercises into one portable device. Features an over-the-door wedge hanger that attaches to 3cm thick doors. Has a 22 step fluted finger ladder that attaches to 3cm thick doors. Includes two 15cm dowels, nylon rope with 73cm travel on a swivel pulley, 9cm hand grips spaced 25cm out from base and a peg for storing rope up and out of the way. Also includes a "wind-up" shoulder wheel with a 91cm nylon rope that features 6.5cm of vertical height adjustment to increase ROM, reach, etc. Height easily adjusts with one revolution of the adjustment knob. There's a rubber ball at the end of the rope for squeezing, grasping and preventing slippage. Length 1.07m. Width 29cm. Depth 35cm. Weight 8.5kg.

5026





DOUBLE RAIL

1 Width and Height Adjustable Parallel Bars

Both the height and width are adjustable on these parallel bars and they can also be folded down for storage. Can be bolted to the floor. Stable and extremely robust with a non-slip plastic laminate coating. Height is adjustable with easy to use locking pins from 69 to 100cm. Width adjustable from 40 to 61cm. Length 230cm. Handrail diameter 45mm.

AA9517

Maximum user weight

140 kg **22 st**



2 Ropox Parallel Bars

The Ropox parallel bars are ideal for walking and balance training as well as training in a standing position. They are ideal for use in hospitals, clinics, day centres, fitness and training centres, and gymnasiums. Available in three lengths and infinitely adjustable between 79 and 103cm in height, they are suitable for every situation. The height is adjusted by depressing the pedal of the gas spring unit situated at one end and pushing the bars to the required height. Recommended mounting width is 70cm but they may be mounted at different widths if required.

Length

AA95113A 3m

AA95113B 4m

AA95113C 6m

Maximum user weight

130 kg **20 1/4 st**



3 SuperPole™ Horizontal Rail System

A portable bar system for short term walking therapy. Simple to install, the SuperPoles are quickly and easily fixed securely between floor and ceiling by jackscrew expansion, only a screwdriver is needed to install. Ideal for situations where a permanent installation may not be an option or where space is an issue. Suitable for both long or short term usage. Rail holder brackets feature non-scratching plastic lining and non-deforming tightening system. Rails are adjustable in height with an extremely low range for paediatric applications. Available as a single or double rail kit system.

Handrail Specifications

Height: 46-100cm. Length: 228cm. Diameter: 4cm.

SuperPole Specifications

Height: 236-253cm. Diameter: 3.8cm.

AA95017 Single Rail Kit System

AA95018 Double Rail Kit System

Maximum user weight

136 kg **21 1/4 st**

MADE TO ORDER
This item is made to order and, therefore, is not refundable.

DELIVERY
Delivery is approximately 4 weeks. Please contact Customer Services for more information.



SINGLE RAIL

1 Height Adjustable Folding Parallel Bars

These parallel bars provide excellent stability and are extremely robust. The bars have a non-slip plastic laminate coating, and the base is hardwearing powder coated steel and chrome, for durability. The bars may be folded flat for easy storage making them ideal for a multi-use therapy room or gymnasium. Height adjustment 69 to 100cm with easy to use locking pins. Height 69 to 100cm. Length 230cm. Width 66cm. Handrail diameter 45mm.

AA9562

Maximum user weight **140 kg** **22 st**



2 Junior - Height Adjustable Folding Parallel Bars

Same design as the parallel bars above, except with a smaller specification to accommodate children. Height 40 to 65cm. Length 186cm. Width 36cm. Handrail diameter 25mm.

AA9513

Maximum user weight **63 kg** **10 st**



3 Westminster Parallel Bars

An extensive range of parallel bars to suit your clinics needs. Available in a variety of lengths, with single or double bars, which can be fixed to wooden or solid floor. A free standing wooden carpet base with sloping ends is also available. Dimensions: Double bar - upper rail height 90cm - lower rail height 67 or 83cm. Single bar - rail height 90cm. Handrail diameter 45mm.

Single Length

AA9564A 182cm

AA9564B 335cm

AA9564C 487cm

AA9564D 640cm

Double Length

AA9563A 182cm

AA9563B 335cm

AA9563C 487cm

AA9563D 640cm

Base Length and Width

AA9566A 250 x 120cm

AA9566B 400 x 120cm

AA9566C 560 x 120cm

AA9566D 720 x 120cm

Maximum user weight **140 kg** **22 st**



SDD UK SAME DAY DESPATCH
Delivered from stock. Please contact Customer Services for more information.

DELIVERY
Delivery is approximately 4 weeks. Please contact Customer Services for more information.

MADE TO ORDER
These items are made to order and, therefore, are not refundable.

INFORMATION
We recommend installation by a qualified tradesman.

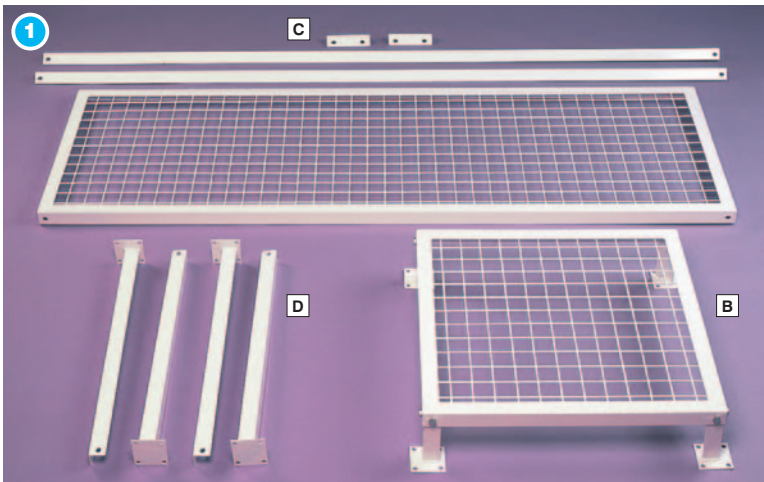
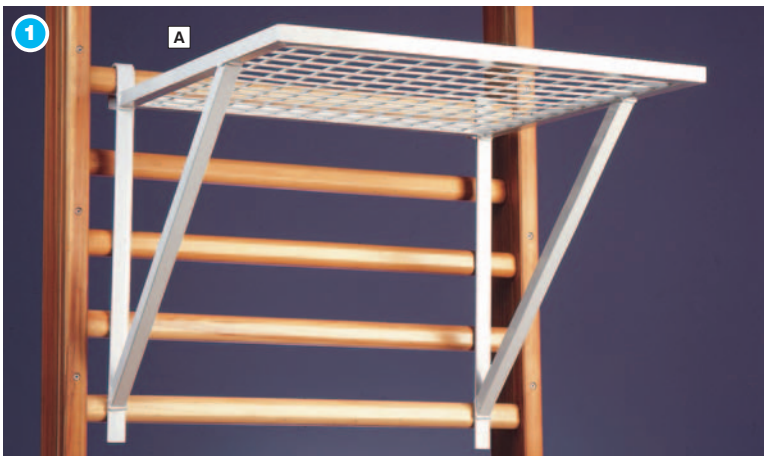

1 Suspension Frames

A high quality range of suspension frames for walls and ceilings. Manufactured from steel with a white epoxy coating.

- AA9570** A Wall Bar Mounted Frame (69 x 69cm)
- AA9571** B Wall Mounted Frame (69 x 69cm - Hangers 15cm)
- AA9572** C Standard Ceiling Frames with Cantilevers (198 x 69cm)
- AA9573** D Standard Ceiling Frames with 4 Ceiling Hangers (198 x 69cm - Hangers 76cm)



Maximum user weight



2 Wall Bars

Wall bars in polished pine, available in single, double and triple sections to suit your clinic requirements. The units are supplied complete with wall fixing kit and instructions.

- AA9560A** Single Section 270 x 86cm **SDD**
- AA9560B** Double Section 270 x 167cm
- AA9560C** Triple Section 270 x 249cm



3 Wooden Stools

These high quality and solid Wooden Stools are available in three different sizes.

- MEF030** Small Stool 35cm x 35cm x 35cm
- MEF035** Med Stool 40cm x 40cm x 40cm
- MEF040** Large Stool 46cm x 46cm x 46cm

4 Balance Benches

Simply the finest Balance Benches available, manufactured in beech and fitted with rubber buttons to avoid damage.

Available in three sizes.

- MEF200** 6ft
- MEF210** 8ft
- MEF220** 10ft

SDD UK SAME DAY DESPATCH
Delivered from stock. Please contact Customer Services for more information.

DELIVERY
Delivery is approximately 4 weeks. Please contact Customer Services for more information.

MADE TO ORDER
This item is made to order and, therefore, is not refundable.

1 Suspension Table

Treatment table for pulleys. Painted steel frame with three removable parts with grids for hook fastening. Table board with tilt-adjustable head and two separate sectors. High-density foam padding with washable leatherette covering.

09 143 0545 Treatment Table with Suspension Frame

Suspension Accessories

- 09 143 0552** **A** 0.5kg Bag
- 09 143 0560** 1kg Bag
- 09 143 0578** 2kg Bag
- 09 143 0586** 3kg Bag
- 09 143 0594** 4kg Bag
- 09 143 0602** 5kg Bag
- 09 143 0610** **B** Arm Strap
- 09 143 0628** **C** Leg Strap
- 09 143 0636** **D** Thigh Support
- 09 143 0644** **E** Heel Support
- 09 143 0651** **F** Ankle Support
- 09 143 0669** **G** Handle
- 09 143 0677** **H** Handle with rings
- 09 139 9633** **I** Nylon Cord
- 09 143 0685** **J** S-shaped hooks
- 09 143 0701** **K** Snap Hook
- 09 143 0719** **L** Tie Rod
- 09 143 0727** **M** Pulley

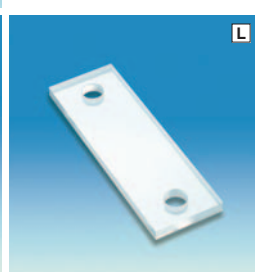
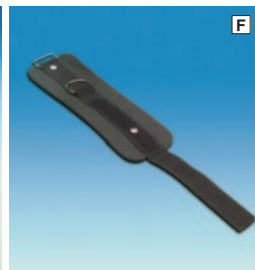

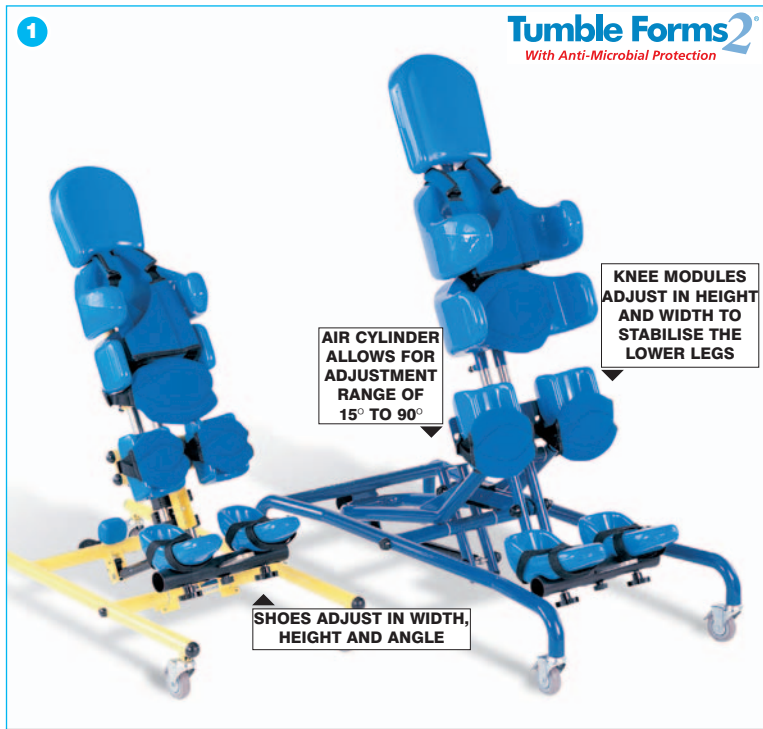

1 Tumble Forms 2[®] Three-in-One TriStander **Sammons Preston**

The TriStander positioner does the job of three conventional standers. Its unique design allows prone, supine and vertical standing. A floor operated pneumatic tilt mechanism makes it easy to adjust the stander from 15° to 90°. The wide range of adjustability in the TriStander allows it to grow with the child. The adjustable module cushions can be mounted on either size frame to accommodate the unique positioning needs of the client. Each cushion is shaped to position the child securely and they are also easy to wash and disinfect. Latex free.

TriStander Features

- Adjustable, soft, cushioned pads
- Pads are seamless, impervious to body fluids and wipe clean
- Module cushions are interchangeable
- 75mm (3") double locking castors prevent roll and swivel

Available in two sizes. The TriStander 45 (yellow frame) accommodates children from 810mm (32") to 1140mm (45") and the TriStander 58 (blue frame) accommodates children from 1090mm (43") to 1470mm (58") in height.

The TriStander Includes

- TriStander frame
- Hip support
- Knee support
- Shoes with bar
- Headrest
- Trunk support

4525S	TriStander 45 (Yellow Frame)		
4530S	TriStander 58 (Blue Frame)		
4526S	TriStander 45 with Activity Tray		
4529S	TriStander 58 with Activity Tray		

TriStander 45		TriStander 58	
Maximum user weight	32 kg	Maximum user weight	68 kg
	5 st		10 1/2 st

2 Tumble Forms 2[®] TriStander Accessories **Sammons Preston**

All of the components, including the frame can be ordered separately as accessories.

TriStander 45 Accessories

4525F	Frame only	545 x 965mm
4525H	Headrest	228 x 247mm
4525K	Standard Trunk Support	215 x 140mm (inside)
4526K	Medium Trunk Support	254 x 165mm (inside)
4525P	Hip Support	215 x 101mm (inside)
4525N	Knee Support (pair)	76 x 57mm (inside)
4525E	Shoes with Bar	216 x 70mm (inside)
4525T	Activity Tray	660 x 660mm
924526	Head Support with Laterals	228 x 241mm (76mm laterals)
924527	Adjustable Trunk Support	192 x 152 to 190mm (inside)
924528	Push Handle	78 x 254mm
924525R	Complete Set of Straps and Pads	

TriStander 58 Accessories

4527F	Frame only	584 x 1194mm
4527H	Headrest	228 x 266mm
4527K	Standard Trunk Support	292 x 152mm (inside)
4526K	Medium Trunk Support	254 x 165mm (inside)
4527P	Hip Support	305 x 152mm (inside)
4527N	Knee Support (pair)	101 x 57mm (inside)
4527E	Shoes with Bar	261 x 89mm (inside)
4527T	Activity Tray	737 x 737mm
924526	Head Support with Laterals	228 x 241mm (76mm laterals)
924527	Adjustable Trunk Support	192 x 152 to 190mm (inside)
924528	Push Handle	78 x 254mm
924530R	Complete set of Straps and Pads	

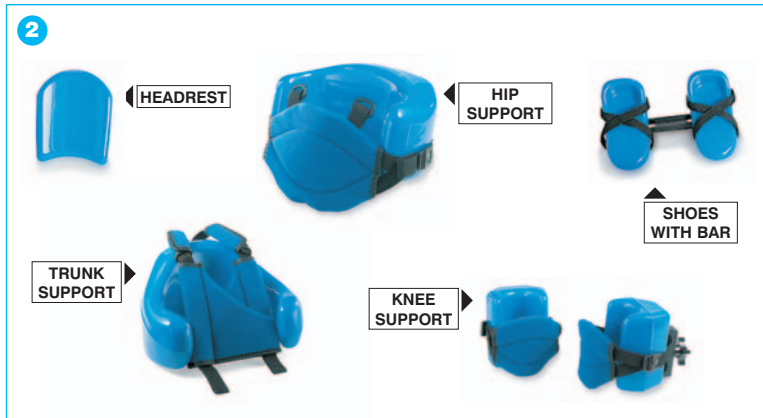

DELIVERY
Delivery is approximately 6 weeks.
Please contact Customer Services for more information.

1 Ultra Slim Fluorescent Lamp

The Ultra Slim Fluorescent Lamp is the only magnifying lamp combining the largest diameter lens of 17.5cm with the most technologically advanced, slimline design and a unique 28 watt daylight tube. The electronic ballast makes it flicker free. Supplied with: 28 watt low heat, high light output, daylight simulation bulb, diffuser and table clamp.

016441**2 Pioneer Mag Lamp**

Specifically designed for medical use, the Pioneer Magnifying Lamp has fully integrated spring mechanisms and cable. Supplied with: 1 x 22 watt light source and lens protector.

009299**010412** Pioneer Bracket**3 Long Handled Brush**

Long-handled soft brush to be used with long-handled dust pan.

008138**4 Long Handled Dust Pan**

Stainless steel dustpan with closing lid, for use with long handled brush.

008137

1



2



3



4



1 2



3

1 Glass Jars

Storage jars for dry items such as cotton wool. Lids supplied separately.

- 005848 10 x 10cm
- 005849 12.5 x 12.5cm
- 005850 15 x 15cm

2 Glass Jar Lids

Stainless steel lids for use with our range of glass storage jars.

- 005845 10cm
- 005846 12.5cm
- 005847 15cm

3 Amber Dropper Bottle

Dropper bottle with rubber pipette for surgery and domiciliary use.

- 004263 10ml



4



5

4 Clear Stock Bottle

The most popular sizes of stock bottle for use in your surgery or domiciliary work.

- 006093 30ml
- 006094 50ml
- 006095 100ml
- 006096 250ml

5 Clear Dropper Bottle

- 006027 30ml

6 Pipette with Red Teat

For use with clear dropper bottle.

- 006028 30ml



6



7 8

7 Clear Polystop/Dropper Bottle

- 006091 30ml

8 Polystop/Dropper

- 006092 For 30ml Bottle

9 Plastic Bottle with Screw Top

A secure top makes this bottle ideal for storage of liquids. Pack of 10.

- 005837 250ml

10 Plastic Bottle with Pump

Ideal for storage of gels and creams.

- 005841 250ml



9



10

11 Plastic Beaker with Screw Top

- 009053 250ml

12 Plastic Tub with Screw Lid

- 008997 30ml

13 Ointment Jar with Screw Lid

- 008123 15ml
- 009179 30ml
- 008120 60ml



11



12

13



1 Plain Aluminium Autoclave Tray

Aluminium for autoclaving instruments.

007641	18 x 14 x 1.9cm	Silver
017175	18 x 14 x 1.9cm	Blue
007654	28 x 18 x 1.9cm	Blue

2 Plain Aluminium Autoclave Lid

007650	18 x 14cm	
007655	28 x 18cm	Silver

3 Perforated Aluminium Autoclave Tray

Aluminium for autoclaving instruments.

007645	18 x 14 x 1.9cm	Blue
017257	18 x 14 x 1.9cm	Silver
017255	28 x 18 x 1.9cm	Silver

4 Perforated Aluminium Autoclave Lid

016444	18 x 14cm
016445	28 x 18cm

5 Plastic Instrument Bath

Plastic box to store instruments after autoclaving, and prior to usage. Made from polypropylene, and can be autoclaved. Maximum temperature 135°C.

007724

6 Gallipot

Gallipots are made of polypropylene and are autoclavable.

005659	90ml
---------------	------

7 Kidney Dish

We stock two sizes of kidney dish, and both are made of polypropylene and are autoclavable up to 134°C.

005657	15cm
005658	20cm

8 Debris Foot Tray

Keep your practice clean by using this debris foot tray to keep skin and nail debris contained while you work.

005470

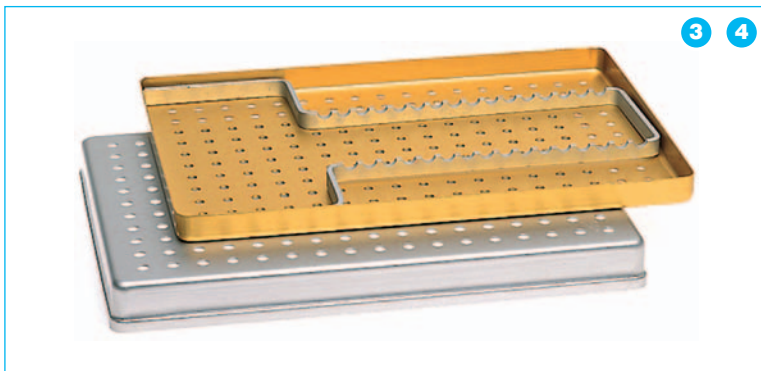

1 2

3 4

5

6

7

8

1



1 Podiatry Domiciliary Bag Mobilis Rolyan

This new Domiciliary Bag only weighs 2kg, making it an excellent option for domiciliary visits. It is manufactured from MicrAgard material which contains silver for anti-microbial protection. It is also fluid repellent, fire retardant, rot proof and waterproof! Provides a safe environment to store your equipment, products, instruments and drill when moving from house to house, and comes with a detachable shoulder strap for comfort and easy carrying.

- Weight when empty: 2kg
- Dimensions: Height 42cm. Width 52cm (incl. side pockets). Depth 25cm.

021867

2 Domiciliary Bag with Wheels Mobilis Rolyan

Similar to the Podiatry Domiciliary Bag above but with wheels to reduce the stress of carrying. Provides a safe environment for transporting equipment when moving between houses.

- Weight when empty: 3kg
- Dimensions: Height 47cm (incl. wheels). Width 52cm (incl. side pockets). Depth 28cm.

021927

3 Carry Case

The Hadewe carry cases are suitable for most Hadewe units, and it is possible to configure the inner spaces to your personal preferences. You can comfortably work from the case due to the doors that open sideways (and also have additional space for your tools). The case further features reinforced wheels, and a carry handle with telescopic extraction. All other supplements as shown here are not included.

Dimensions outside: W 470 x H 370 x D 250mm

Dimensions inside: W 450 x H 160 x D 210mm. Weight: 4.5kg

09 131 7239 Normal with drawer

09 131 7221 Normal without drawer

09 142 5081 Large without drawer

2



3



1 Practica 1 Case

The Practica 1 is a versatile wipe clean pull out drawer system in a shockproof ABS with aluminium frame and key locks. Weight (empty): 5.2kg. Internal dimensions: 412 x 311 x 180mm.

004709

021711 Spare Lock

2 Practica 2 Case

The Practica 2 is a versatile wipe clean pull out drawer system in a shockproof ABS with aluminium frame and key locks. It has the additional benefit of a back lid housing a useful portfolio section for carrying patient records and cards. Weight (empty): 7kg. Internal dimensions: 412 x 311 x 220mm.

004713

021711 Spare Lock

3 Practica 3 Case

The Practica 3 is a versatile wipe clean pull out drawer system in durable PVC and key locks. It also offers a document pocket and end pocket. Weight (empty): 5kg. Internal dimensions: 412 x 311 x 180mm

004775

4 Practica 4 Case

The Practica 4 is a versatile wipe clean pull out drawer system in a lightweight, fully padded 600D polyester zipped bag. It has a removable and wipeable PVC sheet for podiatry use. It comes complete with a handle and removable shoulder strap, two end pockets and a back pocket for documents. Weight (empty): 4.4kg. Internal dimensions: 390 x 300 x 160mm.

004899



1



2



3



4

1



1 Drill Bag

Mobilis Rolyan

This hard wearing bag is manufactured totally from MicrAgard (contains silver), and is also antimicrobial, fluid repellent, and waterproof! It includes an air vent so you can use the drill inside the bag, and a comfort strap for easy carrying.

- Dimensions: 23cm height x 38cm width x 17cm depth

021868

2 Domiciliary Foot Stool and Carry Bag

This two piece moulded plastic foot stool is lightweight and comes with a carry bag. Height 21cm.

004203 Stool and Carry Bag

004200 Domiciliary Stool

004201 Carry bag for stool

2



3



2



3 Complete Tripod Foot Rest

Ideal for domiciliary use, the ultra lightweight black tripod footrest allows the podiatrist to support the foot at an ideal working height. The black tripod footrest is adjustable and lockable. The rest has a comfortable foam top.

008122 Complete Tripod

005636 Tripod Base

005720 Tripod Top

4 Nomad Footrest

The Nomad Footrest is adjustable and lockable. The footrest has a sturdy moulded plastic top. It comes with a carry bag and an adjustable strap for easy transportation. Height: Minimum 45cm. Maximum 67cm. Weight: 1.6kg. In bag 2kg.

005613

5 Foot rest with bag

The foot rest is perfect for the use during domestic work, and assists you in putting the patient's foot where you can best work on it. Height (between 46-92 mm) and multiple angles are separately adjustable. The jolt is extra steel reinforced to prevent breaking under weight. This latest model has some further protective construction to give it more stability. Comes with a carry bag (W 690 x H 320 x D 240mm).

09 121 8288

4



5

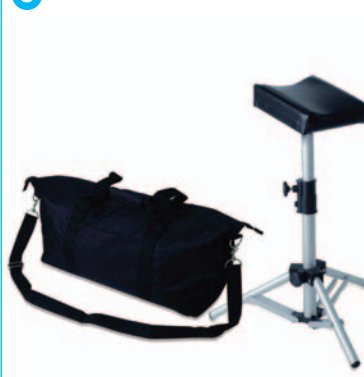

6 Vulkan Medical Bag

The Vulkan Medical Bag is a washable bag offering ample space for storage and a double zipped drop down front panel. Dimensions: 44cm x 24cm x 24cm.

003821

6



1 R.O. Daily Information Pack

Ideal for use with magnetic whiteboards for reality orientation purposes. Excellent for residential home settings. Contains 64 magnetic strips, screen printed with words referring to calendar date and heading such as 'Daily Activities' and 'Staff On Duty'. Three blank strips are also included.

AC1477

2 R.O. Therapy Pack

For use in conjunction with the magnetic whiteboards opposite and Daily Information Pack above. Provides additional word strips including seasons, holidays, meals and weather conditions.

AC1478

3 Magnetic Letters

Bulk pack of 288 brightly coloured magnetic letters (240 lower case, 48 upper case). Easy to handle with rounded edges.

AC1467

4 Magnetic Numbers

Bulk pack of 288 brightly coloured magnetic numbers and symbols. Easy to handle with rounded edges.

AC1468



INFORMATION
For magnetic white boards, please see page 728.



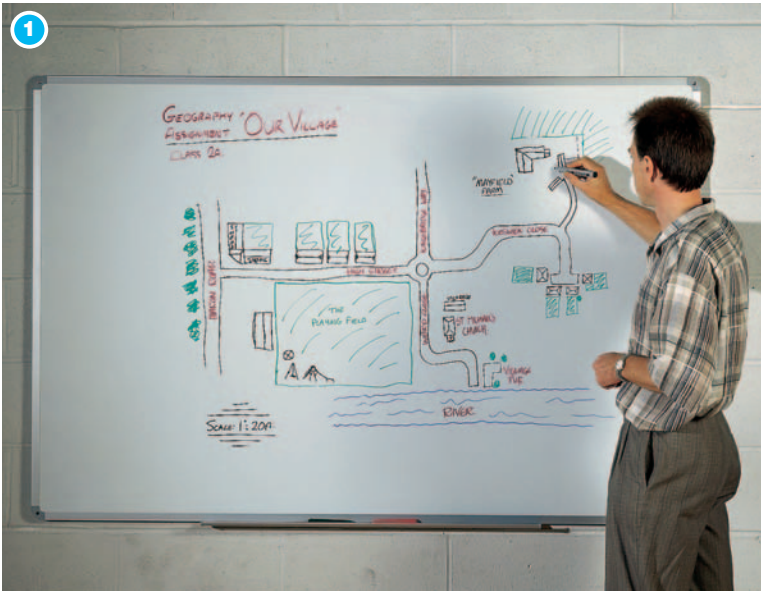

1 Whiteboard

Available in two sizes, this whiteboard is ideal as a reality orientation display source. Attach posters and drawings or use dry wipe markers to display written information.

AC1475 2400 x 1200mm (94¹/₂ x 47¹/₄")

2 Magnetic Whiteboard

Big enough for lots of information, this whiteboard is ideal for reality orientation purposes. Use dry wipe markers to display written information or use with the magnetic letters, numbers and shapes or reality orientation packs opposite.

AC1470 1200 x 1200mm (47¹/₄ x 47¹/₄")

3 Magnetic Write and Wipe Board

A portable magnetic whiteboard for wall mounting or upright tabletop use. Ideal for reality orientation/notice displays or a variety of other activities in small groups or by individuals.

AC1473 610 x 460mm (24 x 18")

4 Portable Magnetic Whiteboard

This portable magnetic whiteboard is double sided and can be used for reality orientation, group activities and by individuals.

AC1476 700 x 450mm (27¹/₂ x 17³/₄")

